

PART A: GENERAL INFORMATION

F820 ICE CREAM MACHINE INSTALLATION & SET-UP GUIDE

VERSION: 101002



FASTCORP®
FOOD AUTOMATION SYSTEMS AND TECHNOLOGIES

One Cory Road
Morris Township, NJ 07960
Tel: (973) 455-0400
Fax: (973) 455-7401

TABLE OF CONTENTS

PART A: GENERAL INFORMATION -1 OF 2PART DOCUMENT

I.	WARRANTY (Refer to Specific Service Contract Terms If Applicable).....	A-iii
II.	COMPONENT REFERENCE AND IDENTIFICATION.....	A-1: A-12
	A. Cabinet.....	A-1
	B. Door Components.....	A-2
	C. Control Panel Components.....	A-3: A-5
	1. Customer Keypad	A-3
	2. Display.....	A-3
	3. Money System.....	A-3
	4. Cable Interface Board.....	A-4
	5. Computer Board.....	A-4
	6. Service Keypad.....	A-5
	7. Power Box.....	A-5
	D. Robot Components.....	A-6: A-10
	1. Robot Carriage, Rack and Trolley Plate.....	A-6
	2. Left/Right & Front/Back Home Switches.....	A-6
	3. Robot Vacuum System	A-7
	4. Up/Down Guide.....	A-8
	5. Robot Carriage Components.....	A-9
	6. Up/Down Home Switch.....	A-9
	7. Up/Down & Front/Back Motors	A-9
	8. Left & Right Yoke Springs	A-9
	9. Up/Down Guide.....	A-9
	10. Vacuum Valve Assembly.....	A-10
III.	SPECIFICATIONS.....	A-11
	A. General Specifications & Measurements.....	A-11
	B. Safety.....	A-11
	C. Maintenance.....	A-11
	D. Cleaning.....	A-11
IV.	UNCRATING INSTRUCTIONS.....	A-12
V.	SETUP INSTRUCTIONS.....	A-13: A-28
	A. Money Systems.....	A-13
	1. MDB Coin Mechanism & Bill Acceptor Installation.....	A-14
	B. Initial Power Up (<i>Homing Sequence</i>).....	A-15
	C. Product Display System.....	A-16: A-18
	D. Bin Setup/ Product Loading	A-19
	E. Preprogramming Configuration.....	A-19
	F. Programming.....	A-20: A-28
	1. Introduction.....	A-20:
	2. Getting started.....	A-21
	3. Menu Items/ Programming Sequence.....	A-22: A-28
	A) Change Price.....	A-22
	B) Sales Meters.....	A-22
	C) Resetable Meters.....	A-22
	D) Edit Selection.....	A-22: A-23
	E) Create Selection.....	A-23: A24
	F) Delete Selection.....	A-24
	G) Selection #s.....	A-25
	H) Set Date.....	A-25
	I) Set Time.....	A-25
	J) Set Service Phone #.....	A-25
	K) Sales PIN Code.....	A-25

TABLE OF CONTENTS

G.	Programming (<i>Continued</i>)	A-20: A-28
	3. Menu Items (<i>Continued</i>)	A-22: A-28
	L) Vend Block.....	A-26
	M) VB Pin Code.....	A-26
	N) Health Timer	A-27
	O) Program Version.....	A-27
	O) Display Language.....	A-27
	P) Line Mode	A-27
	Q) Machine Serial Number.....	A-27
	R) Group Sales Option.....	A-28

PART B: TROUBLESHOOTING GUIDE -REFER TO TROUBLESHOOTING GUIDE (2/2)..... B-i: B-12

I.	Table Of Contents.....	B-i
II.	Troubleshooting.....	B-1: B-12
	A. Glossary Of Useful Terms.....	B-1
	B. Error Reporting Features.....	B-2
	1. Fatal	B-2
	2. Non-Fatal.....	B-2:B-3
	C. Order Of Operations	B-4:B-7
	1. Initiating A Vend Cycle	B-4
	2. Cycle Starting From The Drop Point (<i>Moves On The Y-Axis</i>)	B-4
	3. Cycle Starting From The Home Position (<i>Moves On The X-Axis</i>).....	B-4
	4. Robot Moves On The Y-Axis To Bin.....	B-5
	5. Robot Moves Down The Z-Axis To Bin.....	B-5
	6. Robot Moves Up The Z-Axis (<i>Retrieves Product</i>)	B-6
	7. Robot Moves On The X-Axis To Drop Point.....	B-6:B-7
	8. Robot Moves On The Y-Axis To Drop Point	B-7
	9. Completion of Vend Cycle.....	B-7
	D. Troubleshooting Charts.....	B-8 B-12
	1. L/R Stuck Motor.....	B-8
	2. F/B Stuck Motor.....	B-8
	3. U/D Stuck Motor.....	B-9
	4. Freezer Close Stuck Motor.....	B-9
	5. Freezer Open Stuck Motor.....	B-9
	6. L/R Encoder Error	B-10
	7. F/B Encoder Error.....	B-10
	8. U/D Encoder Error.....	B-11
	9. Out Of Product	B-11
	10. Vacuum Out Of Order.....	B-11
	11. Bin Errors	B-12
	12. Vacuum Problems.....	B-12

COMPONENT REFERENCE AND IDENTIFICATION

Fig. 1 (Cabinet, Front)	Fig. 2 (Cabinet, Front/Left)
	<p style="text-align: center;">No Freezer Chest</p>
1. Leg Levelers (48909107)	16. Customer Keypad Assembly (49410500)
2. Power Supply Assembly (PN 39410200)	17. Bill Acceptor Plate (upper) (19300375)
3. Control Board Power Switch (19300545)	18. Bill Acceptor Plate (lower) (19300375)
4. Light Switch (49105501)	19. Coin Return Button, Coin Lever Return Assembly (19300271)
5. Vacuum Box (49210110)	20. Coin Slot (49400423)
6. Freezer, Complete Assembly (39610000)	21. Coin Mechanism (Located Behind Cover)
7. Freezer Lid Actuator (39610500)	22. Coin Return Funnel (49400311)
8. M-K Motor (49505555)	23. Coin Chute (49410700)
9. Plastic Limit Switch (49500566)	24. Coin Box (49420910) & Coin Box Housing (49100484)
10. Freezer Chest Lid (Not sold separately)	25. Service Switch (19300543)
11. Thermometer (19600738)	26. Vacuum Breaker 10Amp
12. Carriage Assembly (39510100)	27. Main Breaker 15 Amp
13. Controller Board (19300529)	28. Main Power Switch
14. Controller Board Cover (49400295)	29. Freezer Lid Actuator Assembly (39610500)
15. Digital Display (19300521)	30. Exhaust Fan (Optional Feature)

Fig. 3
(Door, Front/Left)

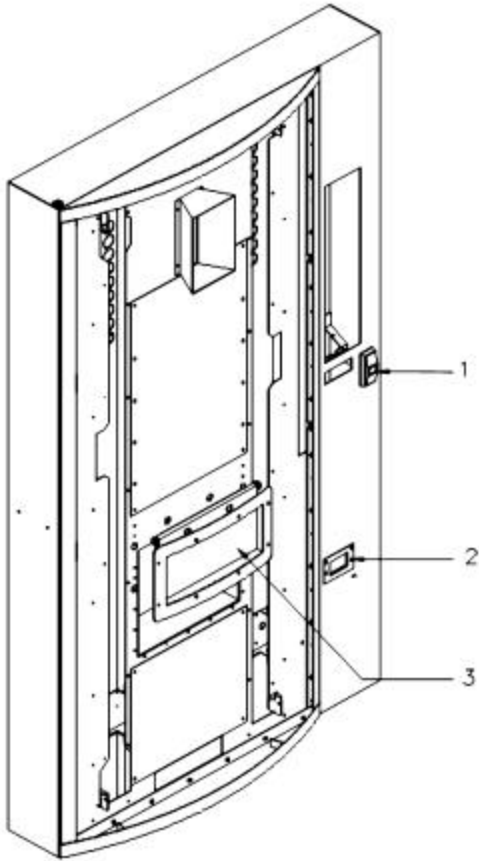

- 1. Door Lock (49300394)
- 2. Coin Return Bezel (49300309)
- 3. Customer Bin Bezel Weld Assembly (49330350)

Fig. 4
(Door, Back)

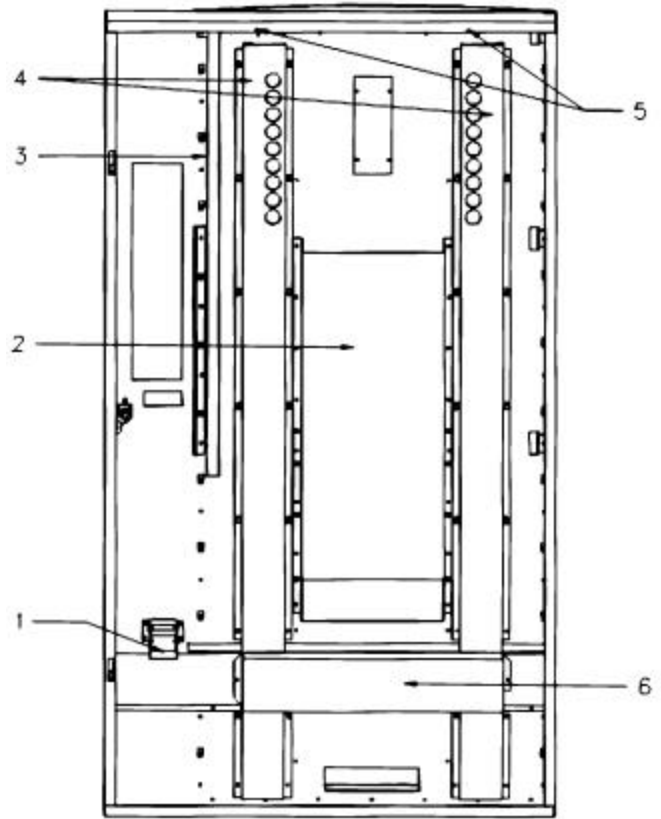

- 1. Coin Return Cup Assembly (49310800)
- 2. Product Chute (49300253)
- 3. Card Holder Slot, Door Body
- 4. Door Light Cover, Left (49300381), Right (49300382)
- 5. Cardholder Hooks (48800105)
- 6. Door Light Cover, Lower (49300384)

Fig. 3
(Control Panel Interior & Exterior)

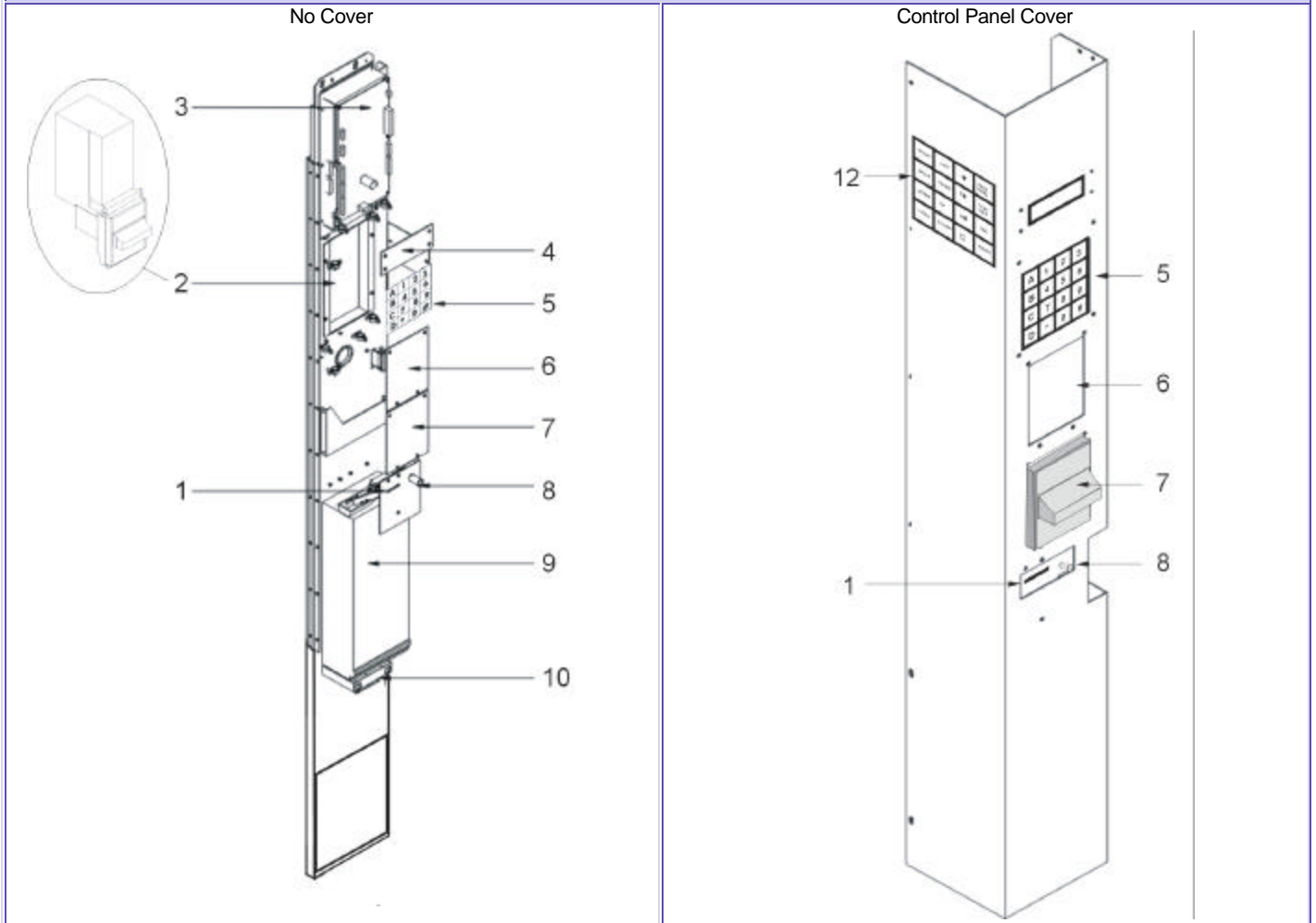

- | |
|---|
| 1. Coin Slot (49400423) Coin Return Lever Assembly (49410610) |
| 2. Bill Acceptor Extension Plate, For Up-Stacker Models (49400302) |
| 3. Controller Board (19300529), Cable Interface Board (49405540) |
| 4. Digital Display (19300521) |
| 5. Customer Keypad (49410500) |
| 6. Blank Bill Acceptor Plate, Upper (19300375) |
| 7. Blank Bill Acceptor Plate, Lower (19300375) |
| 8. Coin Return Button (19300271), Coin Return Lever Assembly (49410610) |
| 9. Coin Mechanism, Refer To Specific Model |
| 10. Coin Return Funnel (49400311), Coin Chute (49420710) |

**Fig. 4
(Computer Board)**

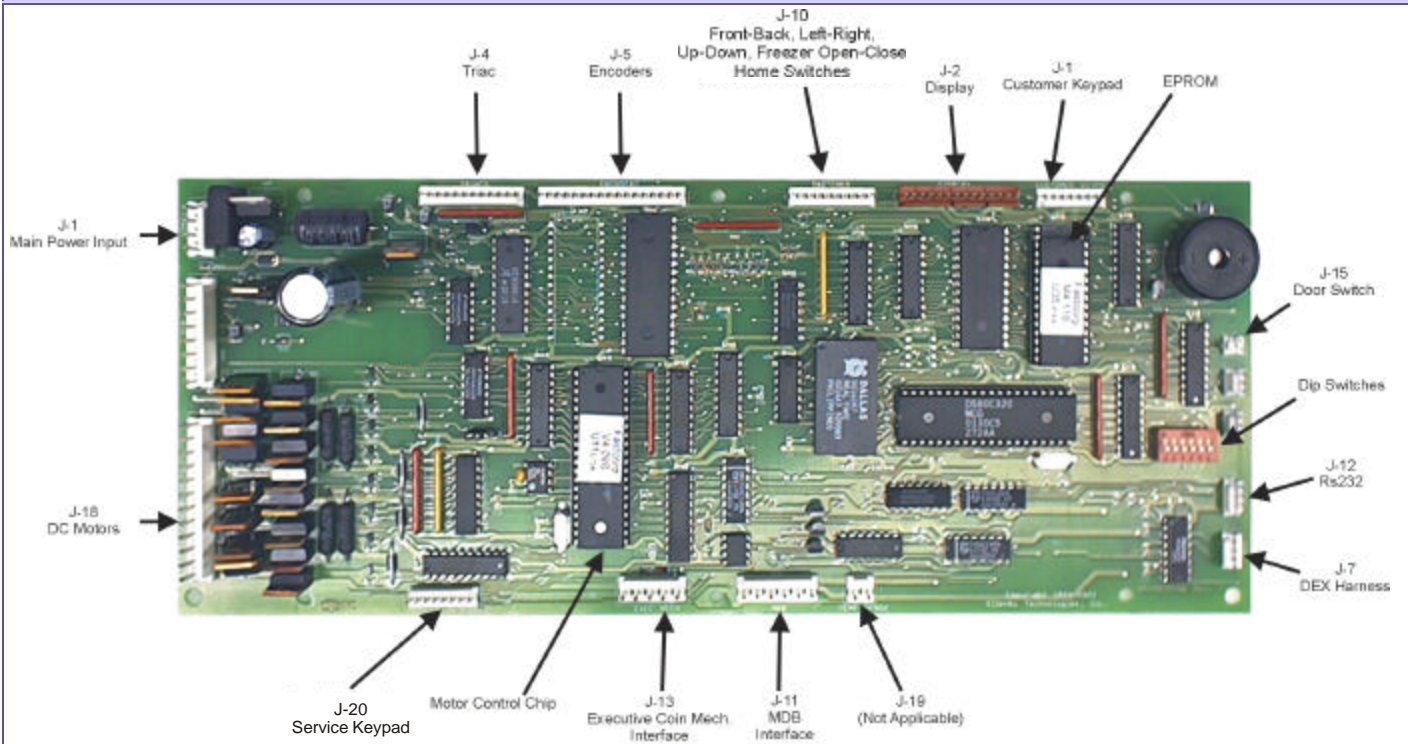

**Fig. 5
(Cable Interface Board)**

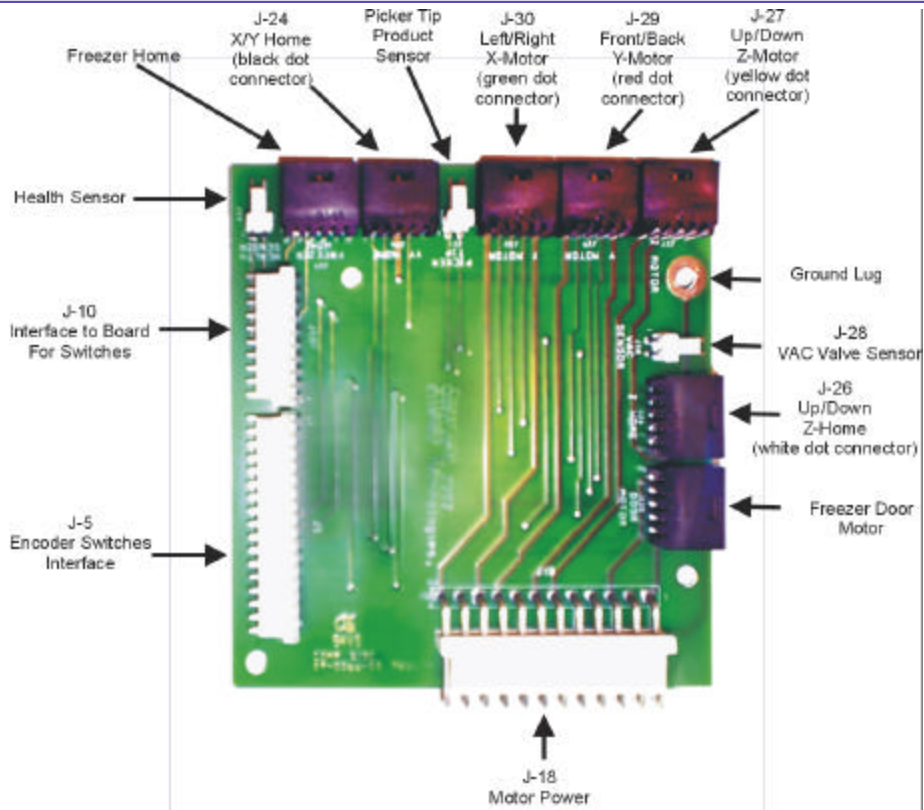

**Fig. 6
(Service Keypad)**

(PN19310500)				RIGHT, LEFT, FRONT and BACK- Moves robot in the respective direction.
RIGHT	LEFT	5¢	FREE VEND	UP and DOWN- Drops or raises the picker head.
BACK	FRONT	10¢	TEST VEND	LOAD and CLOSE- Used to clear sold-out bins and bin errors (press Load then Close).
DOWN	UP	25¢	VAC	5¢, 10¢, 25¢- Releases coins of specified denomination from the coin tubes in the coin mechanism.
LOAD	CLOSE	☐	RESET	FREE VEND- Allows vending without money; press once to enter, once to exit.
				TEST VEND- Allows test vending with money; money is not recorded in the vend meter and it is returned after the vend sequence is completed. Press once to enter, once to exit.
				RESET- Resets the machine in the event of an "OUT OF ORDER" condition.
				The following errors can put the machine out-of-order:
				a) Robot errors: motor, encoder or reed switch
				b) Vacuum motor errors
				c) Coin mechanism errors (coin mechanism not detected)

**Fig. 7
(Power Box)**

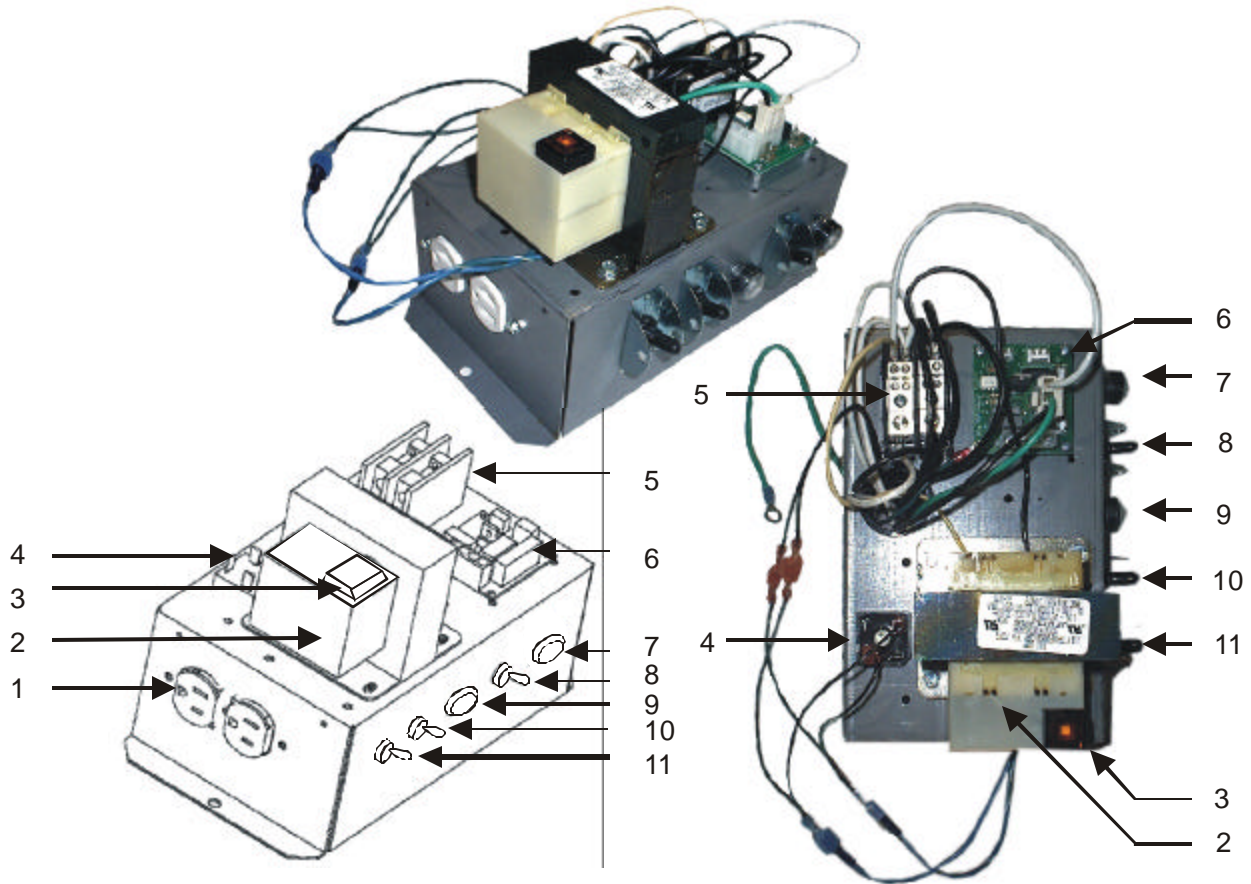

1. Duplex Receptacle	7. Main Breaker (15A)
2. Transformer (24V)	8. Main Power Switch
3. Transformer Reset	9. Vacuum Breaker (10A)
4. Bridge Rectifier (Fan)	10. Light Switch
5. Power Distribution Block	11. Control Board Power Switch
6. Single TRIAC Board	

Fig. 8
(Robot Carriage-Rack Assembly)

Front Right View

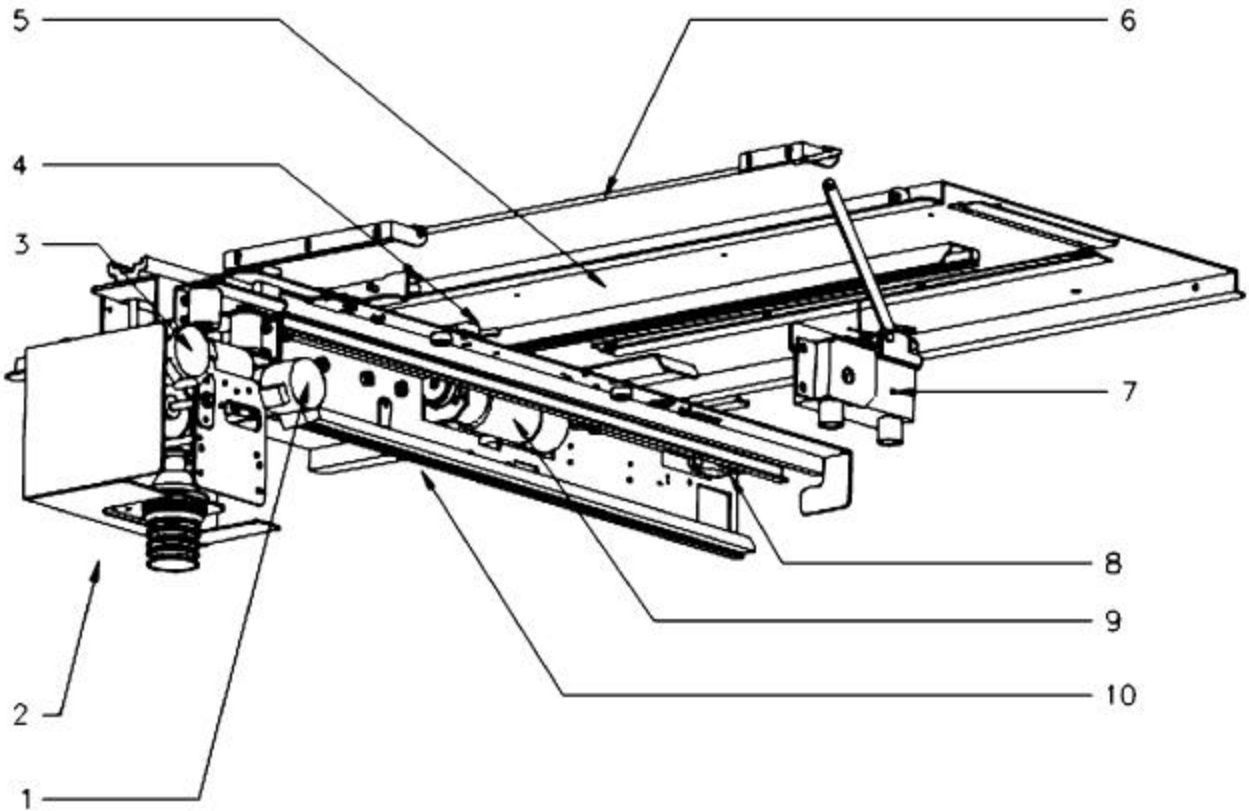

1. M-K Motor, Front/Back (49505555)	6. Crank Assembly, Crank Release (49200178)
2. Carriage Assembly, Robot (39510100)	7. Vacuum Valve Assembly (39210210)
3. M-K Motor, Up/Down (49505555)	8. Plastic Arm Limit Switch, Front/Back- (49500566)
4. Plastic Arm Limit Switch, Left/Right (49500566)	9. M-K Motor, Left/Right (49505555)
5. Trolley Plate Assembly (39510300)	10. Beam Assembly (39510200)

Fig. 9
(Robot Carriage-Rack Assembly & Hose System)

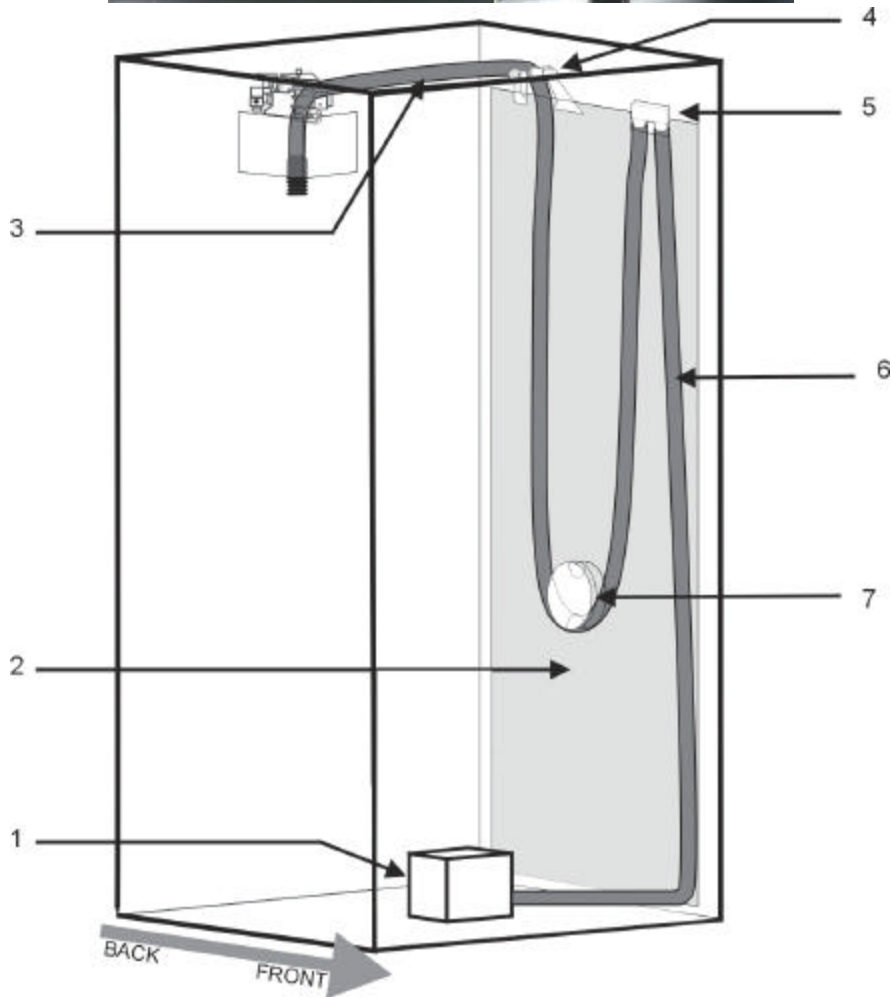
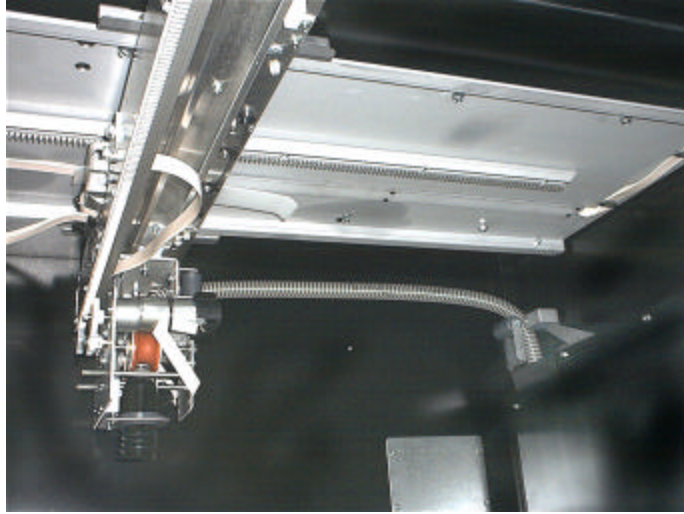

1. Vacuum Box (49210110)	5. Vacuum Valve Assembly (39210210)
2. Hose Panel (49100472)	6. Hose, 88" (49200463)
3. Hose, 130" (49200130)	7. Hose Weight (49200498)
4. Panel Rollers (Short: 49210410) & (Long: 49210420)	

Fig. 10
(Robot Up Position)

Right View

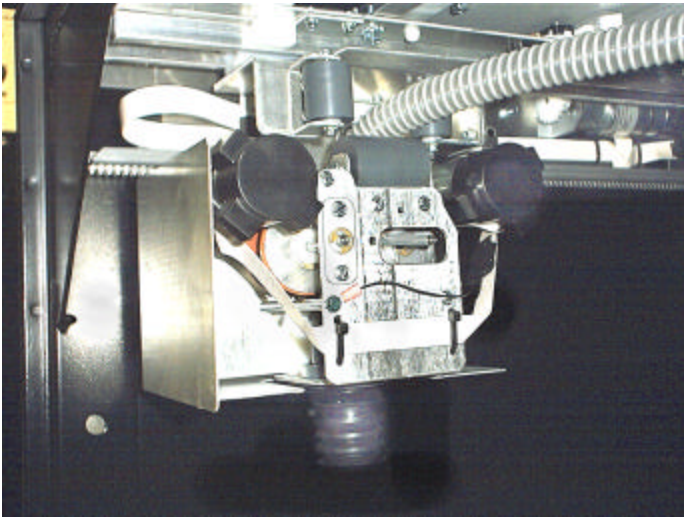

Fig. 11
(Up/Down Guide In The Drop Position)

Bottom Right View

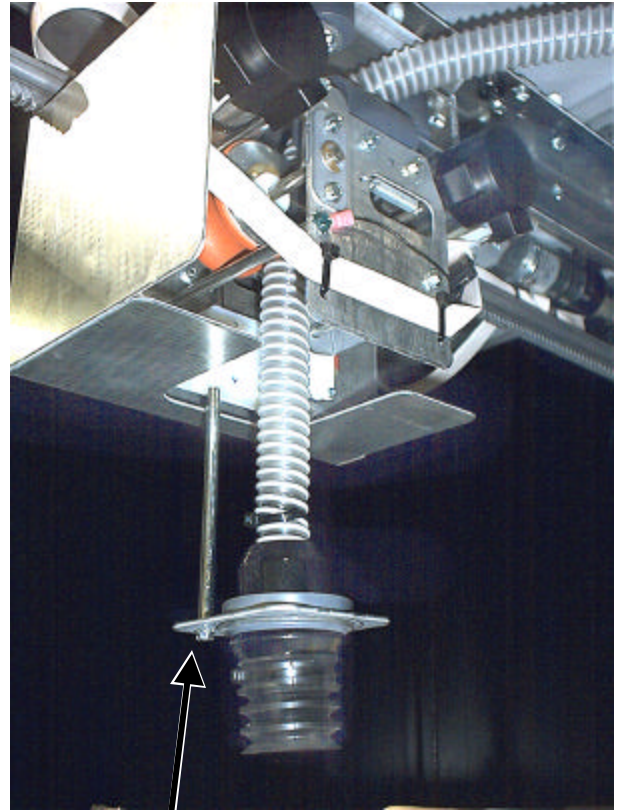
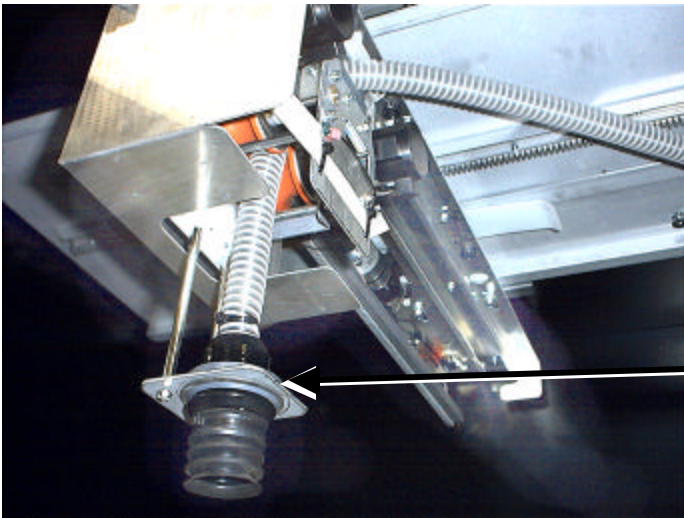

Fig. 12
(Up/Down Guide In The Drop Position)

Bottom View



UP/DOWN GUIDE

Fig. 13
(Robot Carriage Front/Right)

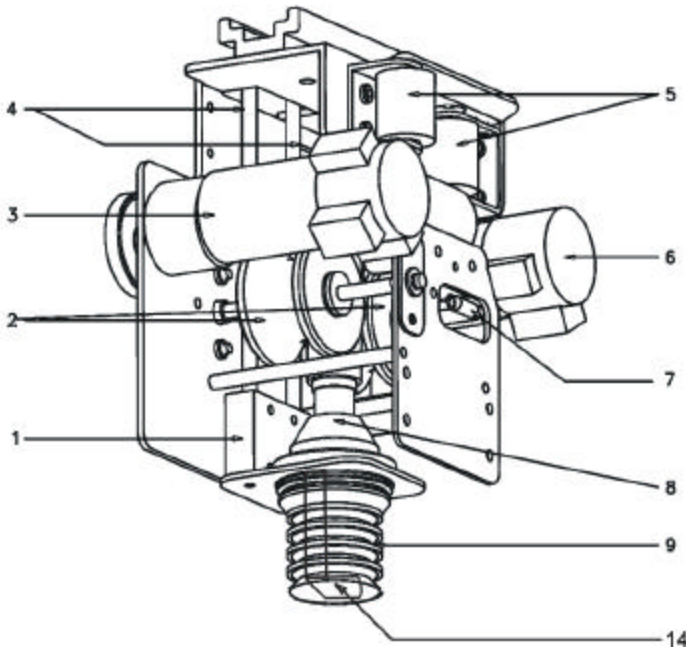
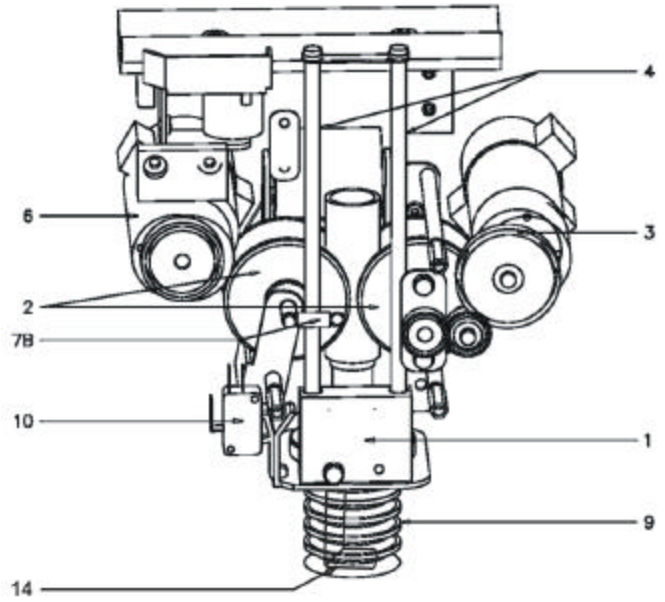

Fig. 14
(Robot Carriage Left)

Left Carriage Plate Not Seen



- 1. Up/Down Guide Block (39503431)
- 2. Rubber Wheels (49500484)
- 3. Up/Down M-K Motor (49505555)
- 4. Up/Down Guide Rods (39503432)
- 5. Vertical Rollers (49500452)
- 6. Front/Back M-K Motor (49505555)
- 7. Right Yoke Spring (48904026)
- 7B. Left Yoke Spring (48904026)

- 8. Picker Weight (39503410)
- 9. Suction Cup (49500461)
- 10. Plastic Arm Limit Switch, Up/Down (49500566)
- 11. Driven Gear 1 (49500405)
- 12. Driven Gear 2 (49500405)
- 13. Guide Plate (49500427)
- 14. Product Sensor (39900530)

Fig. 15
(Vacuum Valve Assembly)

Fig. 16
(Vacuum Valve Assembly)

Left View
(PN 49210210A)

Left View

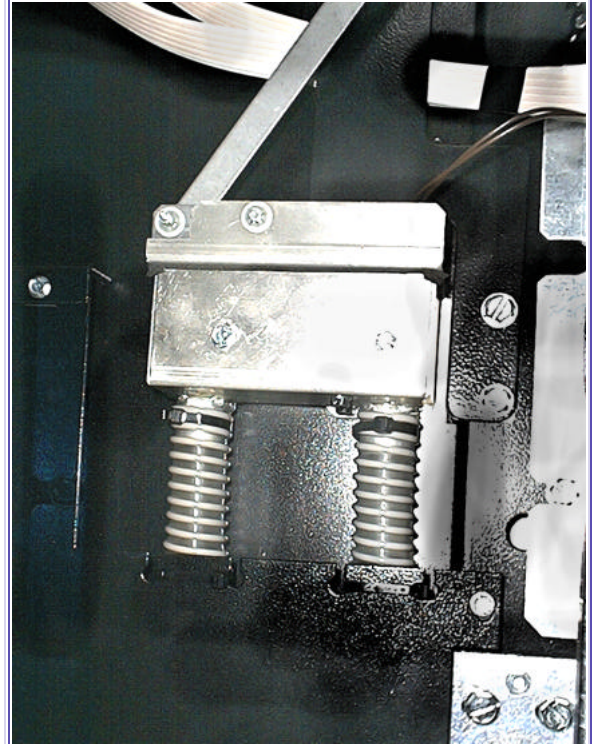
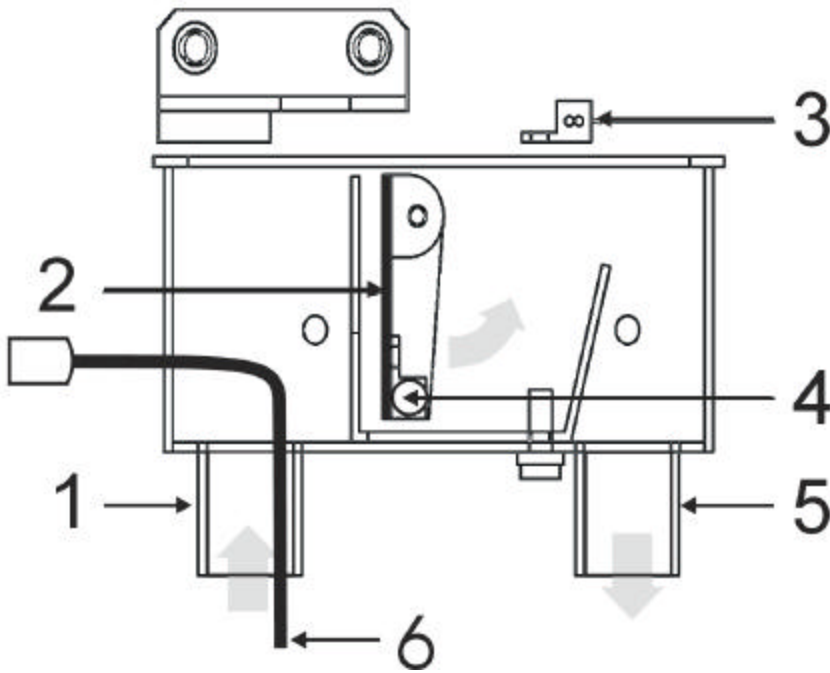

1. Airflow Nozzle- Intake From Robot, Valve Box Weldment
2. Flap Valve (49200069)
3. Magnetic Reed Switch (19900518)
4. Magnet, Reed Switch (19900565)
5. Airflow Nozzle- Out To Vacuum Box, Valve Box Weldment
6. Product Sensor Harness (49500531)

SPECIFICATIONS

GENERAL SPECIFICATIONS

GENERAL		ELECTRICAL	
HEIGHT:	72.0 in./182.9 cm.	VOLTAGE:	110-115 A/C
WIDTH:	39.0 in./90.20 cm.	FREQUENCY:	60 Hz *
DEPTH:	34.5 in./87.70 cm.	AMPERAGE:	9Amps.
WEIGHT:	635-lbs./288 kg.	AMP DRAW:	2.5Amps resting /9Amps operating

* This machine requires a 115V, 15 Amp dedicated circuit. Lower voltage may result in vacuum related problems and/or improper coin acceptance.

SAFETY CONSIDERATIONS

- Only use a 110V 15 Amp electrical power supply with ground to power the machine.
Warning: To ensure safety and proper operation, the machine must be grounded. Do not attempt to remove ground pin from power plug.
- Keep clear of robot path during vend cycles (inside cabinet or near robot carriage assembly). When vending product, the robot accelerates towards the front center section of the cabinet known as the "Drop Point". Standing or looking inside the cabinet while the robot attempts to dispense product may result injury.

MAINTENANCE CONSIDERATIONS

- Note: Do not use oil or other lubricants on any moving parts.

CLEANING CONSIDERATIONS

- Note: Do not use water, soap or any other liquid to clean inside the machine.

UNCRATING INSTRUCTIONS

(A copy of these instructions are attached to the front glass panel of the machine)

This machine has been crated and packed in order to protect its internal components during transportation and distribution. FASTCORP has also attempted to make unpacking and installation a quick and easy process. FASTCORP recommends the following steps be taken when uncrating.

Warning: Do not plug in the machine before all steps are completed in this section. Shipping brackets must be removed before powering machine to avoid damage to sensitive mechanisms

1. Inspect the exterior of the machine for any damage that may have occurred during shipping. The machine has been covered with a cardboard box, so any external damage will be immediately visible. Report any damage to the delivering carrier and follow their claims procedures.
2. Remove the carton from the machine by lifting it off the top. Remove the bag covering the machine. Open the door and inspect the inside for any damage. Close the door and tighten the lock.
3. Use a 1 1/16" socket to loosen each leveler leg (located under the machine, in each of the four corners).
4. Tilt or lift the machine in order to remove the left and right skids.
5. Reopen the door. Remove the robot-retaining bracket located on the left side of the carriage by unscrewing three 1/4-20 bolts. Two bolts are located on the top and screwed into the ceiling of the cabinet. One bolt is located on the side and screwed into the robot. Store the bracket and hardware in the cabinet door next to the bottom door hinge. Remove the four RED tie wraps shown in Fig. 17.
6. Continue to the next section: machine SETUP/ MONEY SYSTEMS & MONEY SYSTEM INSTALATION.

Fig. 17
(Robot Retaining Bracket & Shipping Tie Wrap Locations)

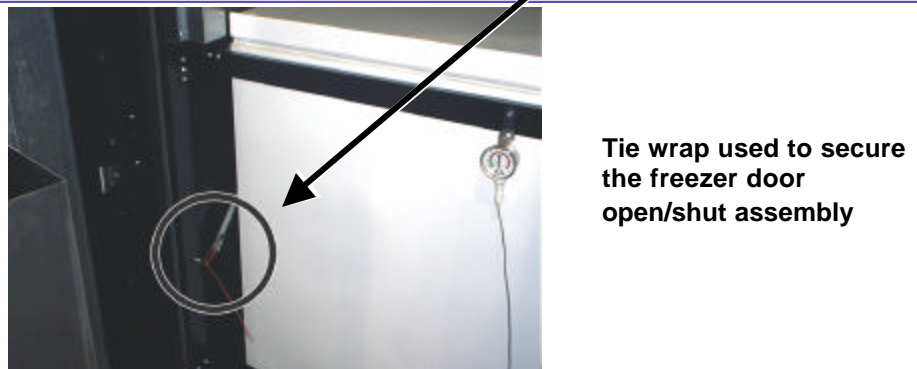
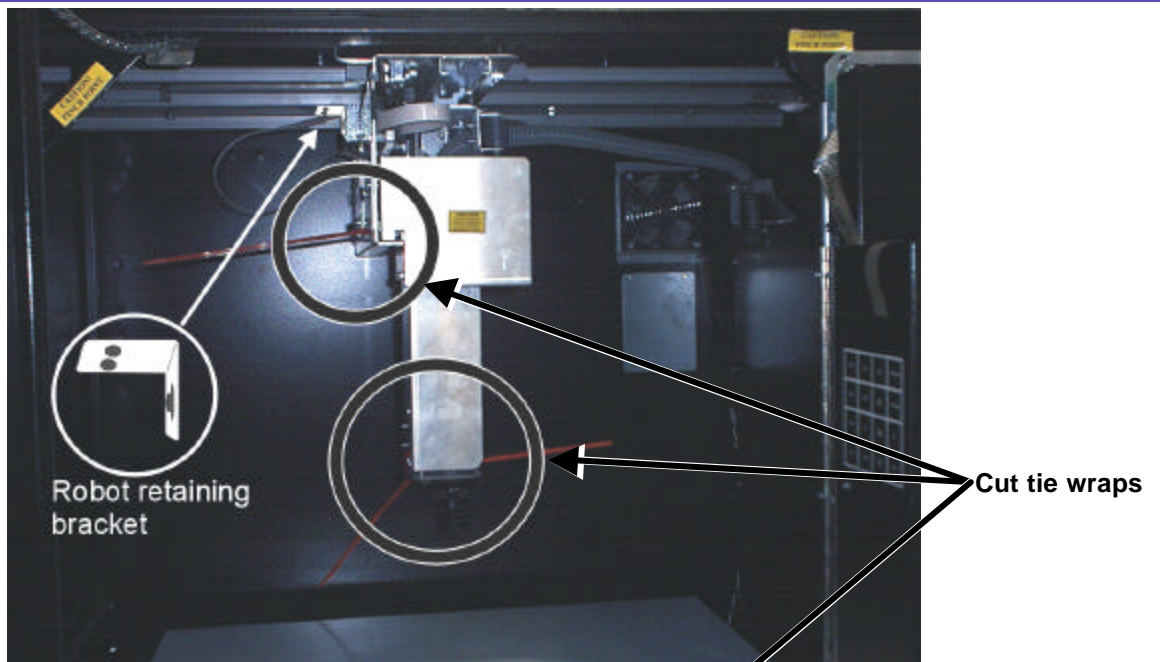

SETUP INSTRUCTIONS

MONEY SYSTEMS

TYPES OF MONEY INTERFACE SYSTEMS

- This machine supports **ONLY** MDB (Multi-drop Bus) Money systems.
- This machine is compatible with any MDB compliant coin mechanism and bill validator.

MONEY SYSTEM INSTALLATION

Multi-Drop Bus (MDB) Interface

1. Open the control panel-cover using the release button located on the right side of the control panel.
2. Mount the coin mechanism using the three coin mech. mounting screws.
3. Mount the bill acceptor using the four mounting screws located on the control panel cover (top or bottom slot depending on type of acceptor used; for card readers, use top slot- MDB only)
4. Make all the connections shown in Fig. 18.

Fig. 18
(Multi-Drop Bus (MDB) Money System Connections and Installation)

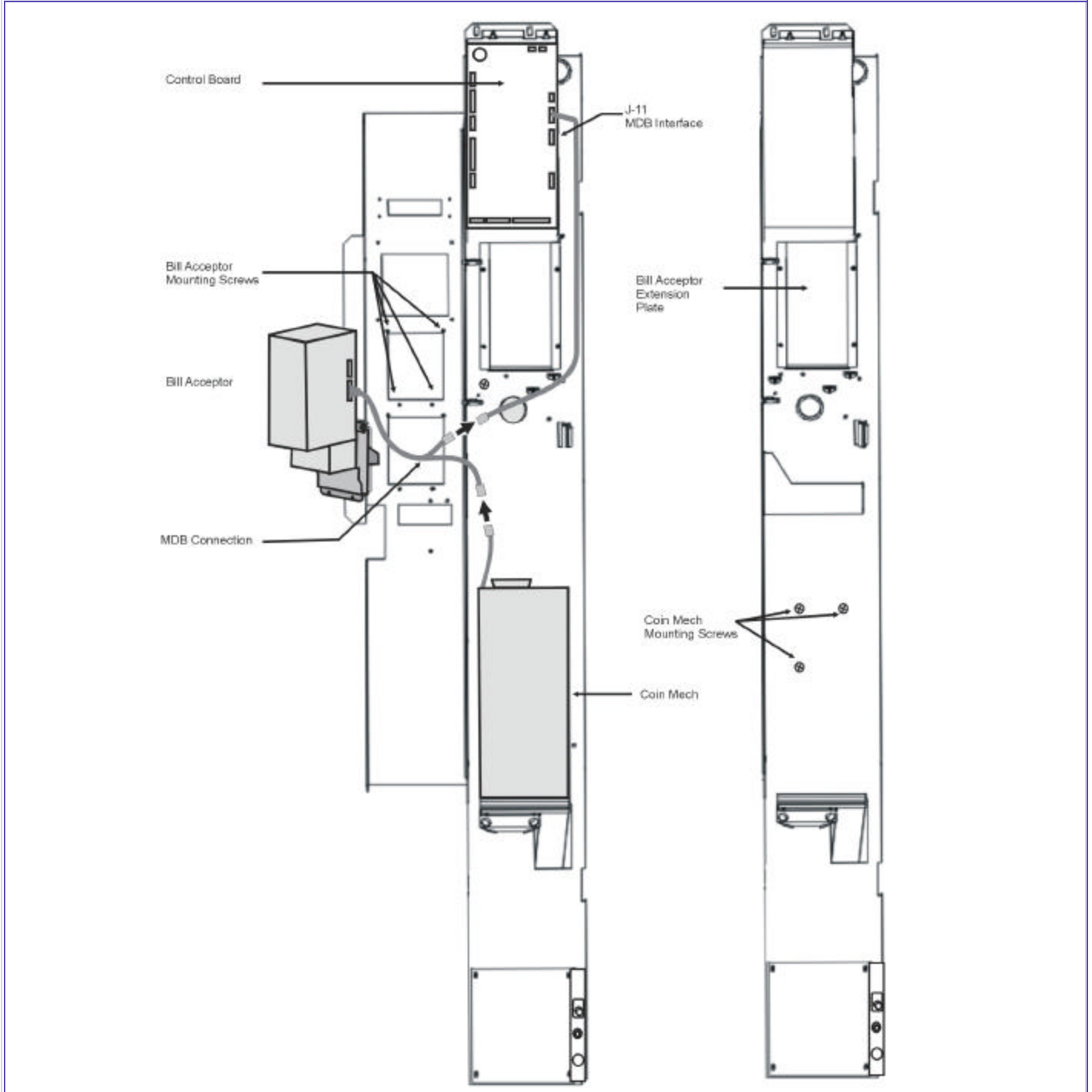

INITIAL POWER UP

Warning: Before starting this section, make sure that all the other sections have been completed (Safety Specifications, Uncrating Instructions, Money System Setup). Do not power up if the robot-retaining bracket and shipping tie wraps have not been removed.

Plug the machine into the power source. To avoid the risk of injury, making sure that all body parts are clear of the cabinet before turning on the main power.

The robot should follow the initial power-up sequence:

1. Robot picker head moves UP.
2. Robot carriage moves towards the LEFT of the cabinet.
3. Robot carriage moves towards the FRONT of the cabinet (considered the HOME position).

If the robot does not move or follow the “Homing Sequence”:

1. There may be setup errors or shipping damage. Review all the previous sections and check for errors on the display. Press the # key for diagnosis.
2. Check the transformer reset breaker and make sure the power switch is on (refer to control panel diagram for location).
3. Perform a quick check to see if there are obstructions preventing the robot from moving freely on all axes.
 - a. Power the machine off to disable “dynamic breaking” features that make it hard to move the robot manually.
 - b. Manually move the robot to the left, right, front and back. Check for smooth travel. Note any obstruction or gear binding.
4. Refer to the Troubleshooting Guide section.

Fig. 19
(Power Up Homing Sequence)

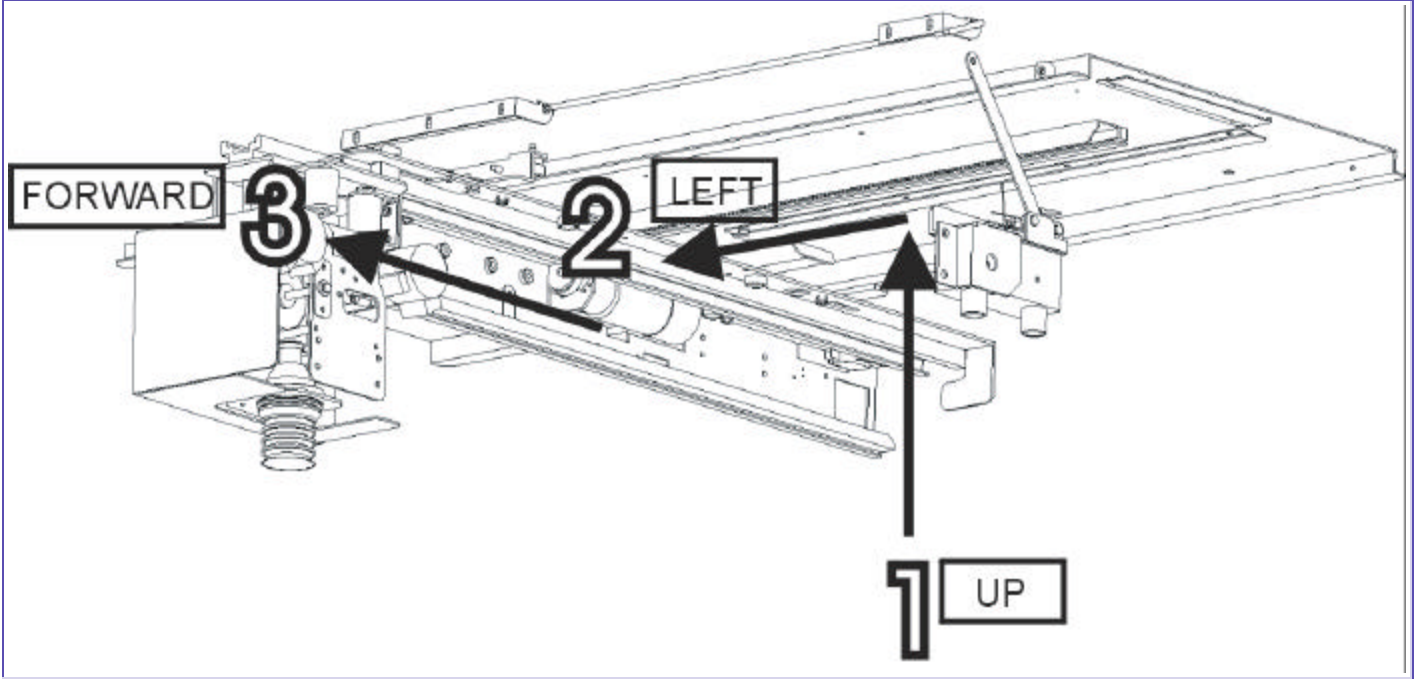

PRODUCT DISPLAY SYSTEM

INSTALLATION AND SETUP

1. Determine what products will be vended and locate the corresponding display card provided by the manufacturer.
2. Open the cabinet door and locate the cardholder display opening in the back cabinet door.
3. Remove the cardholder from the door by lifting up firmly on the left bottom corner of the sheets. Note: the cardholder consists of 3 sheets, which are attached at the top with plastic grommets.
4. Once the left bottom corner has been lifted out of cardholder opening, use your finger or pen (recommended) and run it up the entire length of the opening (bottom to top) until the cardholder is free.
5. Slide the cardholder out of the door display.

Cardholder
Opening

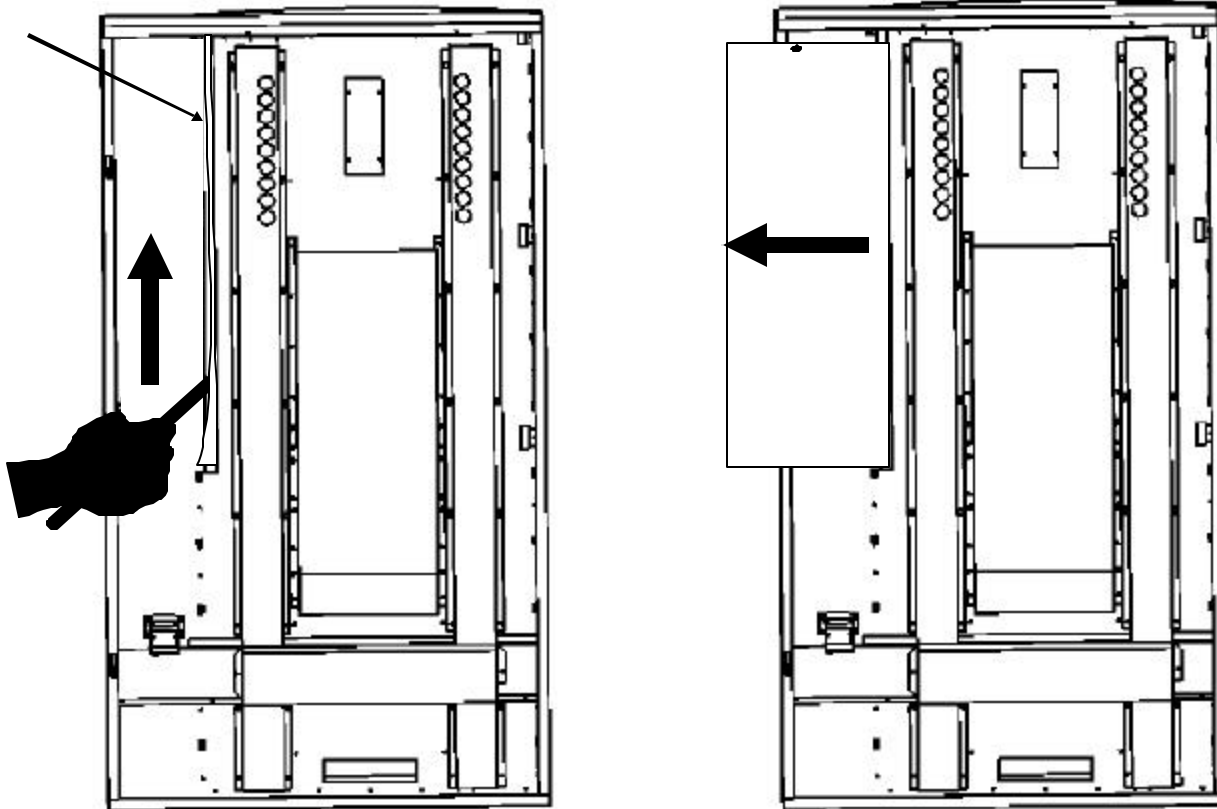

6. Hang the cardholder from the top of the cabinet door using the mounting holes located on the top of the display sheets and the mounting clips located on top of the door.
7. Lift the first sheet off the center cardholder sheet and drape over the cabinet door.

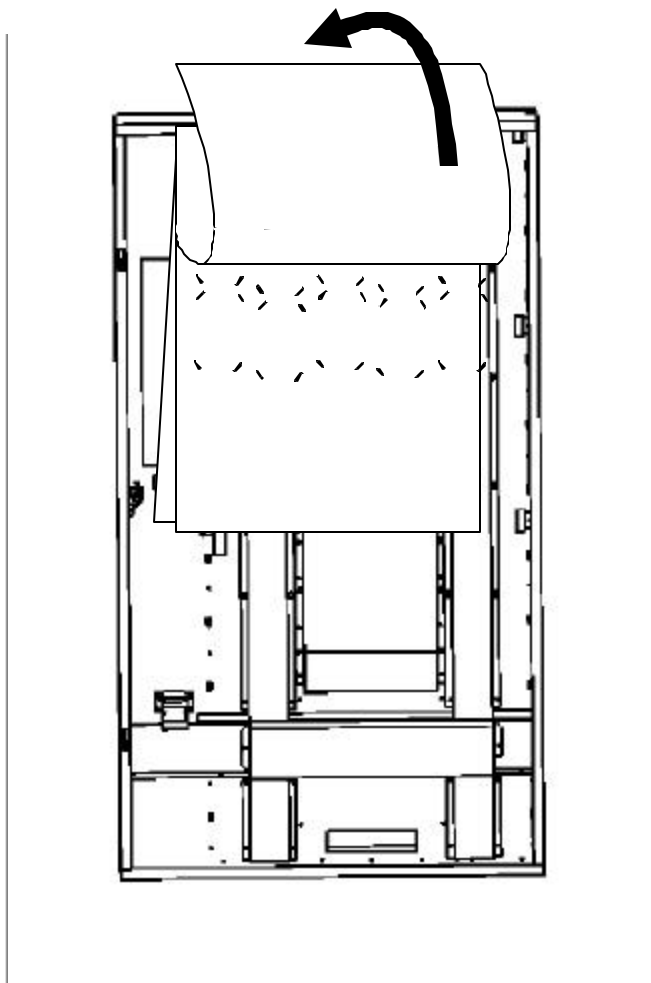
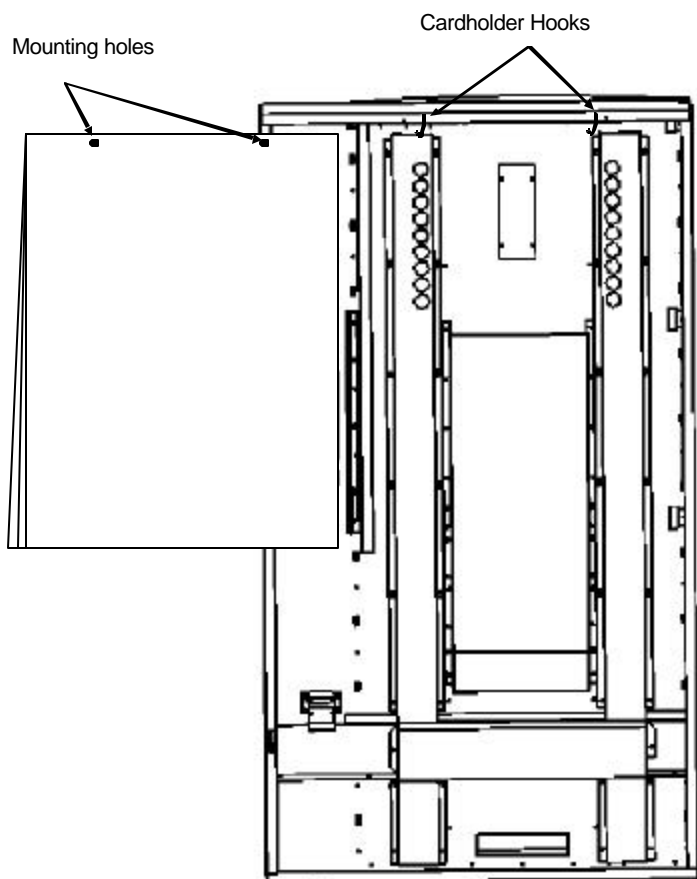

8. Attach price labels to each card.
9. Install the display cards on the center cardholder sheet. The slots located on this sheet are used to hold and secure each of the four corners of a display card.
10. Remove the cardholder from the mounting clips and reinstall. Using a fair amount of pressure to snap the cardholder back in place.

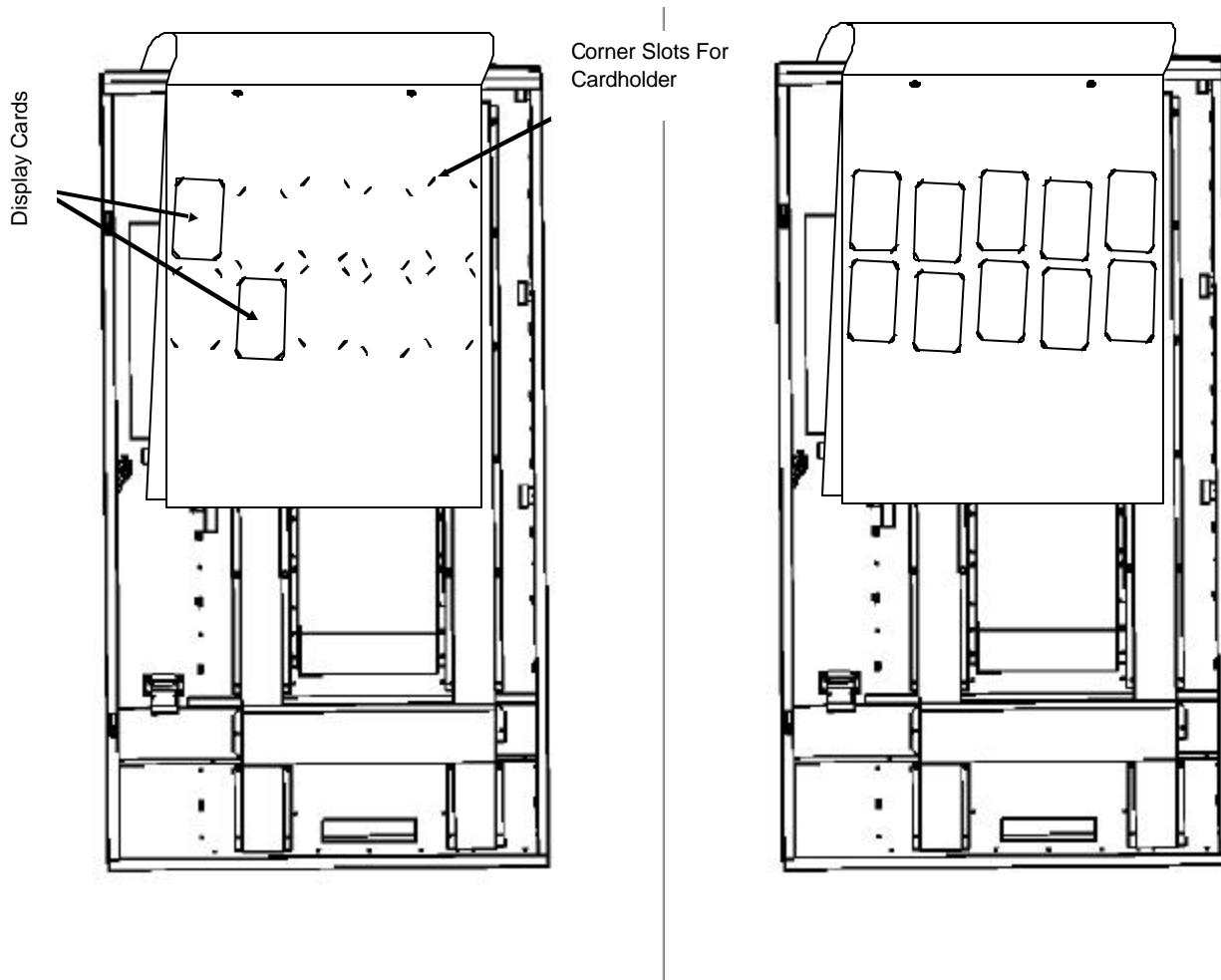

BIN SETUP/ PRODUCT LOADING

The machine utilizes a bin system to hold product. Unlike most conventional snack machines utilizing a horizontal spiral system, the machine is able to hold product vertically, giving the machine increased storage capacity (up to 8 times greater than the competition).

There are a number of different sized bins used in the machine. The type of bin used depends on the size and shape of the product being vended. Every machine comes pre-configured from the factory with a specific bin layout or “Bin Plan-o-gram”, chosen by the customer at the time of order.

Note: Please refer to the Bin Layout Guide (accompanying this manual) for plan-o-grams and instructions specific to your machine.

GENERAL CONSIDERATIONS

- Always keep a copy of the specific bin plan-o-gram in each machine. It will be used as a reference tool for loading product and error code referencing.
- Always keep a copy of each machine’s specific bin plan-o-gram at a remote location (office) as a reference and backup copy.
- When reordering bins, refer to the bin part numbers detailed on the machine’s bin plan-o-gram.
- Always load product from the bottom-up (so that product will be vended FIFO: First In, First Out).

PREPROGRAMMING CONFIGURATION

CONTROLLER BOARD DIPSWITCH OPTIONS

SWITCH	NAME	OPTION
1	ESCROW:	ON to enable bill acceptor escrow; OFF to disabled escrow
2	SELECTION DIGITS:	ON to make selection 2 characters; off 1 character
3	FORCE VEND:	ON to enable force vend (customer must make selection)
Selection		
4	NOT USED:	No function
5	AUTO-TEST:	(Used only for factory testing)
6	NOT USED:	No function

Clearing The Memory

Even after computer boards or chips have been changed, legacy selection numbers and bin locations may still exist in memory. To completely clear the machine’s memory:

1. Power down the machine.
2. Turn all dipswitches to “on” on the computer board.
3. Power up the machine.
4. The screen will display “Factory Test Press Any Key”. Press a key and the screen will change to “Testing External RAM” for about one second.
5. The screen will display “Checking Real Time Clock”. Disconnect the power and return the dipswitch settings to normal.

PROGRAMMING

INTRODUCTION

The machine comes from the factory without any preset selection numbers or bin locations in memory. All information is entered during initial setup and programming. Programming is completely menu driven. Simply scroll through the menus until the desired function is reached. Once inside a menu function, the computer will prompt the user to enter the required information.

Programming Menus can be accessed in Service Mode. The machine enters Service Mode every time the cabinet door is opened. A list of menu items can then be viewed on the digital display by pressing the “*Next” key on the customer keypad.

Programming Menus (Software Version DC913)

1) <u>CHANGE PRICE:</u>	Allows the price to be changed.
2) <u>SALES METERS:</u>	Allows sales data to be viewed. The total sales meter is non-resetable, and offers a total sales and unit counter.
3) <u>EDIT SELECTION:</u>	Allows existing selections to be edited: Price, Product Height (1-4 in.) and Bin (adjust bin location, add bins to the selection number or change bin height).
4) <u>CREATE SELECTION:</u>	Allows a selection to be created.
5) <u>DELETE SELECTION:</u>	Allows a selection to be deleted.
6) <u>SELECTION NUMBERS:</u>	Allows programmed selection numbers to be viewed.
7) <u>SET DATE:</u>	Allows date to be set or viewed.
8) <u>SET TIME:</u>	Allows time to be set or viewed.
9) <u>SERVICE PHONE #:</u>	Allows service phone number to be set. The number is displayed when the machine is out-of-order.
10) <u>SALES PIN CODE:</u>	Allows pin code to be set and viewed for machine auditing. Pin code can be viewed without opening the door.
11) <u>VEND BLOCK:</u>	Allows the machine to be disabled for predetermined periods of time.
12) <u>VEND BLOCK PIN CODE:</u>	Allows pin code to be set and viewed and allows access to the vend block times from outside the machine.
13) <u>HEALTH TIMER:</u>	Not used with the snack machine.
14) <u>PROGRAM VERSION:</u>	Displays current version of operational software (e-prom).
15) <u>DISPLAY LANGUAGE:</u>	Allows the programmer to choose the language displayed on the screen.
16) <u>LINE MODE:</u>	Not used with the snack machine.
17) <u>MACHINE SERIAL NUMBER:</u>	Allows the programmer to program the serial number of the vendor for machine identification during DEXing.
18) <u>GROUP SALES OPTION:</u>	Allows the programmer the ability to have up to four different metered accounts.

GETTING STARTED: CREATING SELECTIONS

1. Before creating a selection, the front product display must be setup. Product and bins must be preloaded in the machine.
2. In Service Mode, press the “*Next” key and scroll to “4 CREATE SELECTION”. “4 CREATE SELECTION” allows new selections to be created (Note: do not start programming yet).
3. Menu item "4 CREATE SELECTION" will require the following information to be entered:

1. Enter a selection number:	A1 to D1
2. Enter the price:	\$.05-\$9.95
3. Enter the height of the product:	1-4 inches
4. Move the robot over center of the product:	Controls on service keypad: front/back, left/right, down/up
5. Enter the length of the bin:	Short/tall
6. Add more than one bin for the selection:	Yes/No

4. In the Programming Menus section, locate the flow chart for the menu item "4 CREATE SELECTION" and follow the step-by-step instructions for programming new selections.
5. Once selections have been programmed, use the other available menu items to edit and select operating preferences. Refer to Menu Item Description for an overview of each menu item and its features.
6. Once programming is complete, it is important to perform a test to make sure that the machine was programmed correctly. By pressing “Free Vend” on the Service keypad, the machine will allow menu selections to be vended without money. Test each bin selection. Press “Free Vend” again to deactivate this feature.

“Test Vend” on the service keypad allows money to be inserted in order to test menu selections without affecting sales meters. Money deposited will be returned after each test vend. Press “Test Vend” again to deactivate this option.

PROGRAMMING/EDITING AFTER THE MACHINE HAS BEEN OPERATING

1. After the machine has been programmed and operating in the field, any sold out or bin errors that have occurred will be displayed once the door is opened (Service Mode). A bin error occurs if the robot has made three unsuccessful attempts to retrieve a product from a single bin. An “Out Of Product” is displayed when a bin is determined empty.
2. **Note: It is important to view all bin errors before loading or editing bin selections.** Do not press “* Exit” before viewing all bin errors. To scroll through the list of all bin errors including selection and bin number, use the “#Next” key on the customer keypad.
3. Perform a “Free Vend” on these bins to verify that the robot was programmed over the center of the product and that product was loaded properly.
4. To clear all bin errors and “Out Of Product” bins, press “Load” and then “Close” on the service keypad.
5. The machine is ready to be edited and/or loaded with product.

MENU ITEM PROGRAMMING SEQUENCE

1) CHANGE PRICE

Changing the price of programmed selections.

Display	Programming Instructions
1) CHANGE PRICE *=Next Menu #=Yes	a) Press the #=Yes key.
Edit Selection #: _ _ *=Exit	b) Enter the selection number.
A1 Price: \$1.00 *=Abort #=Yes	c) Type over the price.
A1 Price: \$1.50 Accept? *=No #=Yes	d) Press the #=Yes key to enter the price change.

2A) SALES METERS

Choose from two types of sales meters: (a) Non-Resetable (total cash and unit meter that cannot be reset) and (b) Resetable (offers individual and total sales by product which can be cleared/reset).

Display	Programming Instructions
2) SALES METERS *=Next Menu #=Yes	a) Press the #=Yes key.
Choose Meter Type *=Total #=Resetable	b) The Total Meter is a non-resetable sales and unit counter.
Total = \$1575.30 Units = 975 #=Exit	c) Press the #=Exit key to exit and return to SALES METERS.

2B) RESETABLE SALES METERS

SALES METERS *=Next Menu #=Yes	a) Press the #=Yes key.
Choose Meter Type *=Total #=Resetable	b) Press the #=key to enter resetable meter.
A1: \$50.00 25 *Scroll #=Next	c) Press the *=Scroll key to view each selection's sales or the #Next key to view total sales.
\$ 10,250 5,000 *=Clr 1/01/95 #=EXIT	d) Press the *=Clr key to clear the meter or the #=Exit key to save the information.
Are You Sure? *=Yes #=Exit	e) Press the *=Yes key to erase the meter.

3) EDIT SELECTION

Choose from three sub-menus: (a) Change Price, (b) Product Height, (c) Edit Bins- adjust bin location and add bins to a selection number.

Display	Programming Instructions
3) EDIT SELECTION *=Next Menu #=Yes	a) Press the #=Yes key.
EDIT SELECTION # _ _ *=EXIT	b) Enter the selection number that will be edited. Choose from three sub-menus.
Change Price (Sub-Menu)	Edit selection prices.
Change Price *=Next #=Yes	c) Press the #=Yes key or move to the next sub menu.
A1 Price: \$1.00 *=Abort #=Yes	d) Type over the price and press the #=Yes key.

Accept? A1 Price: \$1.50 *No #=Yes	e) Press the #=Yes key to enter the price. Next change product height.
Product Height (Sub-Menu)	Enter the height of the product (1-4 inches). The robot will leave one product at the bottom of each bin so the service person only has to match the products.
*=Next Product Height #=Yes	a) Press the #=Yes key to alter Product Height.
*=Next A1 Height: 1inch (1-4) #=Yes	b) Press the *=Next key for heights 1-4 inches. Press #=Yes key to enter new product height.
Accept? A1 Height: 3inches *No #=Yes	c) Press the #=Yes key to enter the product's height.
Edit Bins	Adjust bin location and add bins to a selection number.
*=Next Edit bins (Sub-menu) #=Yes	a) Press the #=Yes key to enter.
*=Abort A1 Program bin #1? #=Yes	b) The robot will move to location of A1, bin one. Press the #=Enter key to verify location of bin 1, the robot will move to programmed location. You may accept the current location or make adjustments using the service keypad.
*=Cancel A1 Move the Robot #=Accept	c) Press the #=Accept key to store location of the robot. Note: do not program selection on or near the home position, gussets and end zones.
*=Next A1 Bin Height: Short? (Tall) #=Accept	d) Press the *=Next key to select tall or short bin, then press the #Accept key to store bin height. Note: short bins are located on top of cash box and vacuum box.
Accept? A1 Bin Height: Short *No #=Yes	e) Press the #=Yes key.
*=No More Bins? #=Yes	f) Press the #=Yes key to program or edit additional bins #2, 3, or 4 for selection A1 or press the *=No key to store just one bin. (Program is stored).

4) CREATE SELECTION:

Create up to eighteen brand new selections, with 1-4 bins per product display.

Display	Programming Instructions
4) CREATE SELECTION *Next Menu #=Yes	a) Press the #=Yes key to enter create selection menu.
#_ # *=Exit	b) Enter the selection number you wish to create.
Create? Enter Selection #A1 *No #=Yes	c) Press the #=Yes key to enter the selection number.
*=Abort A1 Price: \$0.00 #=Enter	d) Type in the price and press the enter key.
Accept? A1 Price: \$1.50 *No #=Yes	e) Press the #=Yes key to enter the price.

A1 Height: 1 inch (1-4 inches) *=Next #=Accept	f) Press the *=Next key until you have selected the height of the product, then press the #=Accept key. If you have selected the proper product height the robot will leave one product at the bottom of the bin for the route driver to match the products when filling the machine.
A1 Height: 2 inches Accept? *=No #=Yes	g) Press the #=Yes key to enter the product's Height.
A1 Program Bin #1 *=Abort #=Enter	h) Press the #=Enter key to create a bin for the selection number.
A1 Move Robot *=Cancel #=Accept	i) Go to the inside service keypad and move the robot over the center of product you have selected. Press the right button first. Hold the button down to accelerate, pulse your finger on the button to move in 1/16" increments. Move the robot forward and then drop the picker head to verify that is centered over the bin. Press the #=Accept key on the customer keypad to store the location of bin 1. <i>(An alternative to using the motion buttons is to move the robot by hand. However, before the robot can be moved manually, the "Right" and "Front" buttons must be used to move the robot off of the home switch positions. Once off the home switches, the robot can be centered over the desired bin. Attempting to manually move the robot while on the home switch positions may result in programming inaccuracies regarding bin coordinates.)</i>
1 Bin Height: Short (Tall) *=Next #=Accept	j) Press the *=Next key to see Bin Heights. Press the #=Accept key to enter Bin Height.
A1 More Bins? * =No #=Yes	k) Press the *=No key if only one bin is being programmed. The programming for that selection is complete. Simply repeat this process with another selection number. Press the #=Yes key if two or more bins are needed for that selection number. A total of four bins per one selection number are available.
A1 Program Bin #2? *=Abort #=Enter	l) Press the #=Enter key to program a second bin for the selection number.
A1 Move Robot *=Cancel #=Accept	m) Move the robot to the second bin. Press the #=Accept key to enter second bin location.
A1 Bin Height: Tall (Short) *=Next #=Accept	n) Look inside freezer and verify if the bin is tall or short. Press the #=Accept key to enter bin height.
Program Bin 3? *=No #=Yes	o) Enter selection.

5) DELETE SELECTION

Delete the selection.

Display	Programming Instructions
5) DELETE SELECTION* *=Next Menu #=Yes	a) Press the #Yes key to enter menu item.
Delete Selection #: A1 (All selections) D=Delete *=Exit #=Next	b) Press the #=Next key to list selection numbers. Press the D=Delete key to delete the selection.
Delete Selection # A5 OK? *=No #=Yes	c) Press the #=Yes key to delete selection

6) SELECTION #S

View the current programmed selection numbers.

Display	Programming Instructions
*=Next Menu #=Yes	a) Press the#=Yes key to view selection numbers.
Programmed: A1 *=Exit #=Next	b) Press the#=Next key to list selection numbers.

7) SET DATE

Set or view the current date.

Display	Programming Instructions
*=Next Menu #=Yes	a) Press the#=Yes key to enter set date menu.
Enter Date: 01/01/96 *=Abort #=Enter	b) Type in new date and press the#=Enter key to store. Date format: MM/DD/YY
Enter Date: 01/05/96 Accept? *=No #=Yes	c) Press the#=Yes key to store new date.

8) SET TIME

Set or view the current time.

Display	Programming Instructions
*=Next Menu #=Yes	a) Press the#=Yes key to view menu selection.
Enter Time: 15:30:00 (military time) *=Abort #=Enter	b) Type current time and press the#=Enter key.
Enter Time: 15:45:00 Accept? *=No #=Yes	c) Press the#=Yes key to store the current time.

9) SET SERVICE PHONE

Enter, update, or view the service phone number. The programmed number will appear on the display screen in the event that the machine goes out-of-order.

Display	Programming Instructions
*=Next Menu #=Yes	a) Press the#=Yes key to enter menu selection.
Phone (###) ### - #### *Abort	b) Type in service phone number.
Phone (###) ### - #### Accept? *No #Yes	c) Press the#=Yes key to store.

10) SALES PIN CODE

View or change the PIN code that can access sales information without opening the door; while in "Please Insert Money" mode, Press # * and the four numbers you selected.

Display	Programming Instructions
SALES PIN CODE *=Next Menu #=Yes	a) Press the#=Yes key to view or change sales pin code.
Enter Pin: #*1234 *=Abort	b) Type in new four-digit number.
Enter Pin: #*1996 Accept? *No #=Yes	c) Press the#=Yes key to store pin number.

11) VEND BLOCK

Block out vending up to four times per day, seven days per week. Time and date must be entered correctly in SET TIME and SET DATE programming.

Display	Programming Instructions
11) VEND BLOCK *Next Menu #Yes	a) Press the #=Yes key to enter menu selection.
Vend Block: Off (On) *Scroll A=Abort #Enter	b) Press the *=Scroll to turn vend block on and press the #=Enter key.
Day: Sun A=Abort C=Copy D=Delete *=Scroll #Enter	c) Press *Scroll to the day you wish to begin and press the #=Enter key.
Mon Blk 1 on __: __ *Abort #Enter	d) Type in the first time you would like the machine to be off and press the #=Enter key.
Mon Blk 1 On 09:00 (military time) Accept? *No #Yes	e) Press the #=Yes key to store the time.
Mon Blk off __: __ *Abort #Enter	f) Type the time you want the machine to turn on and press the #=Enter key
Mon Blk 1off 11:00 Accept? *No #Yes	g) Press the #=Yes key to store the time; repeat up to four blocks per day.
Mon Blk 2on __: __ *Abort #Enter	h) Press the *=Abort key at the end of the needed blocks, or press enter to continue more blocks.
Day: Mon A=Abort C=Copy (Copies information from day to day) D= Delete *Scroll #Enter	i) (C=Copy: copies information from day to day) To copy one day to another, press *=Scroll key to the day you want to copy, then press the #=Enter key.
Copy Mon to Tues Accept? *No #Yes	j) Press the #=Yes key to copy.

12) VB PIN CODE

Set or alter the VEND BLOCK option from the outside of the machine without opening the door.

Display	Programming Instructions
12) VB PIN CODE *Next Menu #Yes	a) Press the #=Yes key to enter VB Pin code menu.
VB PIN CODE: #*5678 *Abort #Yes	b) The vend block pin code is factory set at #*5678. Use the factory setting or type over four new digits and press the #=Yes key. Type this code when you are in the "Please Insert Money" mode to gain direct access to the VEND BLOCK menu item.

13) HEALTH TIMER (Not used with the snack machine)
 Allows the health sensor to be bypassed for a short time.

Display	Programming Instructions
14) HEALTH TIMER *=Next Menu #=Yes HEALTH TIMER: OFF (1hr, 2hr, 3hr) *=Next #=Accept HEALTH TIMER: 2hrs Accept? *=No #=Yes	a) Press the #=Yes key to display the health sensor options. b) Press *=Next to select time. c) Press #Accept to set timer. d) Press #Yes to start timer.

14) PROGRAM VERSION
 Shows the date and version of the E-prom.

Display	Programming Instructions
14) PROGRAM VERSION *=Next Menu #=Yes	a) Press the #=Yes key to view program version.

15) DISPLAY LANGUAGE
 Allows the programmer to change the language of all external text; all programming will still be displayed in English.

Display	Programming Instructions
16) DISPLAY LANGUAGE *=Next Menu #=Yes	a) Press the #=Yes key to display the current language.
*=Scroll English "A"=Abort #=Enter	b) Press the "A" key to abort (or exit) menu. Press the #=Enter key to reconfirm English. Press the *=Scroll key to scroll to French, Portuguese, or Spanish and press the #=Enter key to confirm the change.

16) LINE MODE (Not used with the snack machine)
 Line mode will allow the machine to detect a line and allow for a quicker vend cycle time (the default is ON).

Display	Programming Instructions
16) LINE MODE *=Next Menu #=Yes LINE MODE: ON *=Scroll "A"=Abort #=Enter	a) Press the #=Yes key. b) Press the "*" key to select the desired option. c) Press the "#" key to confirm the selection.

17) MACHINE SERIAL NUMBER
 Program the serial number of the vendor into the computer so that an external data retrieval unit can include the serial number when downloading sales information. Program this feature only if an external data retrieval device will be used.

Display	Programming Instructions
17) MACHINE SERIAL NUMBER *=Next Menu #=Yes	a) Press the #=Yes key. b) Enter the serial number of the vendor, found on the inside of the door, being sure to add zero(s) if the number is less than six digits. Press the #=Enter key to accept.

18) GROUP SALES OPTION

Vend sales can be recorded into 4 different accounts, each with specific vend times. Example: all sales between 7:00 A.M. and 1200 P.M. may be recorded into account "A"; sales between 12:00 P.M. and 2:00 P.M. may be recorded into account "B"; sales after 2:00 P.M. can go into a third account or back into account "A". All information recorded can be obtained by accessing "Sales Meters" once this option has been set.

Note: If a sale occurs outside of a metered block, it will be recorded into the main meter and not into one of the four accounts.

Display	Programming Instructions
18) GROUP SALES OPTION *=SCROLL A=ABORT #=ENTER	a) Press to the #=Enter key to enter this menu. b) Press the *=Scroll key to move forward.
Day: SUN A=ABT C=CPY D=DEL *=SCRL #=ENTER	c) Press the *=SCRL key to scroll through the days of the week. For Sunday, (as pictured above) press the #=ENTR key to enter.
SUN BLK 1 ON _ _ : _ _ *=Abort #=Yes	d) Enter the start of the desired meter time. Note: All times must be listed in military time. If the time is before noon, you must enter a zero first. e) Press the #=Yes key after the four digits have been entered.
SUN BLK 1 OFF _ _ : _ _ *=Abort #=Yes	f) Enter the end of the desired meter time and press the #=Yes key.
GROUP (A-D): A *=Abort #=Enter	g) Press the letter of the account you wish the sales be recorded into (A, B, C, or D) and press the #=Enter key. h) Enter additional blocks of time if desired; if not, press the *=Abort key to exit the screen. Press the "A" key to exit the next screen, and "A" once more to return to the main menu.

CONTINUE TO PART B: TROUBLESHOOTING

PART B: TROUBLESHOOTING GUIDE

**F820 ICE CREAM MACHINE
INSTALLATION & SET-UP GUIDE**

VERSION: 101002



One Cory Road
Morris Township, NJ 07960
Tel: (973) 455-0400
Fax: (973) 455-7401

TABLE OF CONTENTS

<u>PART A: GENERAL INFORMATION</u> -REFER TO DOCUMENT (1/2)	Ai: A30
<u>PART B: TROUBLESHOOTING GUIDE</u> -2 OF 2 PART DOCUMENT.....	B-i: B-12
I. Table Of Contents.....	B-i
II. Troubleshooting.....	B-1: B-12
A. Glossary Of Useful Terms.....	B-1
B. Error Reporting Features.....	B-2
1. Fatal	B-2
2. Non-Fatal.....	B-2:B-3
C. Order Of Operations	B-4:B-7
1. Initiating A Vend Cycle	B-4
2. Cycle Starting From The Drop Point (<i>Moves On The Y-Axis</i>)	B-4
3. Cycle Starting From The Home Position (<i>Moves On The X-Axis</i>).....	B-4
4. Robot Moves On The Y-Axis To Bin.....	B-5
5. Robot Moves Down The Z-Axis To Bin.....	B-5
6. Robot Moves Up The Z-Axis (<i>Retrieves Product</i>)	B-6
7. Robot Moves On The X-Axis To Drop Point.....	B-6:B-7
8. Robot Moves On The Y-Axis To Drop Point	B-7
9. Completion of Vend Cycle.....	B-7
D. Troubleshooting Charts.....	B-8 B-12
1. L/R Stuck Motor.....	B-8
2. F/B Stuck Motor.....	B-8
3. U/D Stuck Motor.....	B-9
4. Freezer Close Stuck Motor.....	B-9
5. Freezer Open Stuck Motor.....	B-9
6. L/R Encoder Error	B-10
7. F/B Encoder Error.....	B-10
8. U/D Encoder Error.....	B-11
9. Out Of Product	B-11
10. Vacuum Out Of Order.....	B-11
11. Bin Errors	B-12
12. Vacuum Problems.....	B-12

TROUBLESHOOTING

GLOSSARY OF USEFUL TERMS

<i>Term</i>	<i>Definition</i>
Vacuum Valve	An assembly comprised of a valve with a magnetic reed switch that detects airflow and a vacuum seal; used to indicate whether the robot has made contact with product or if product has been dropped.
Controller	The computer board.
Encoder & Encoder Pulses	A device used to send a given number or pulses per gear rotation that can then be interpreted by software to determine distance and location; allows the controller to calculate position of any bin and product drop point relative to the True Home Position. Encoders are built into the L/R, F/B and U/D motors.
Home on the X-axis	The relative Home Position indicated by the Left/Right Home Switch Trigger located at the left side of the cabinet.
Home on the Y-axis	The relative Home Position indicated by the Front/Back Home Switch located at the back of the cabinet.
Home on the Z-axis	The relative home position indicated by the Up/Down Home Switch; when the picker head is in the full up position.
Home Position or (True) Home Position	The home coordinate on all axes (X, Y and Z); located at the back left corner of the cabinet.
Product Drop Point	The range of coordinates on the X-axis and the coordinate on the Y-axis where the robot drops product into the product delivery chute; located in the front/center area of the cabinet.
VAC Error & VAC key	Log used by the computer to store fatal machine errors. Use the VAC key on the Service Keypad to view the VAC error log.
Fatal Errors & Non-Fatal Errors	Fatal errors are errors that will put the machine out-of-order. Non-fatal errors will only put a specific bin out-of-order.
**Left/Right, Front/Back and Up/Down Home Switches can be referenced as part: Plastic Arm Limit Switch (49500566A)	

ERROR REPORTING FEATURES

Two types of errors:

1. Non-Fatal Errors	
<p>Localized errors that put a specific bin out-of-order without taking the machine off line. Bin errors, including bin and selection number, are listed on the digital display when the machine enters Service Mode (open door to enter Service Mode). The customer keypad functions “*= Exit” and “#=Next” can be used to scroll through each error.</p>	
Out Of Product	This error occurs when the robot reaches the “virtual bottom” of the bin (2 predetermined encoder distances on the Z-axis; one for tall and one for short bins)
Bin Load Error	This error occurs after the robot makes 3 unsuccessful attempts to vend product (vacuum seal is lost/product dropped) and puts that bin out-of-order. 9 consecutive, vacuum related Bin Errors become a VAC: “Vacuum Out of Order”.
<p>*Note: It is important to view and check all Out Of Product and Bin Errors, by performing a free vend. Non-fatal errors are cleared by viewing them and then pressing *= Exit on the Service Keypad.</p>	

2. Fatal Errors	
<p>Errors that put the entire machine out-of-order to prevent further component damage. Fatal errors are stored in the VAC log. They can be viewed by pressing the VAC button on the service switch while in Service Mode. The digital display will list up to 4 VAC errors.</p>	
Left/Right (L/R) Stuck Motor	The error that occurs when the robot tries to home itself on the X-axis and times out before triggering the Left/Right Home Switch.
Front Back (F/B) Stuck Motor	The error that occurs when the robot tries to home itself on the Y-axis and times out before triggering the Front/Back Home Switch.
Up/Down (U/D) Stuck Motor	The error that occurs when the robot tries to home itself on the Z-axis and times out before triggering the Up/Down Home Switch.
Freezer (Open/Close) Stuck Motor	The error that occurs when the freezer tries open or close and times out before triggering the Freezer Open or Closed Switch.
Left/Right (L/R) Encoder Error	The error that occurs when the controller fails to see encoder pulses on the X-axis after 3 unsuccessful tries. This error can occur from either the Home Position to the bin, the bin to the Product Drop Point or the Product Drop Point to the bin.
Front Back (F/B) Encoder Error	The error that occurs when the controller fails to see encoder pulses on the Y-axis after 3 unsuccessful tries. This error can occur from either the True Home Position to the bin, the bin to the Product Drop Point or the Product Drop Point to the bin.
Up/Down (U/D) Encoder Error	The error that occurs when the controller fails to see encoder pulses on the Z-axis, on the way down to the bin.
Freezer (Open/Close) Encoder Error	The error that occurs when the controller fails to see encoder pulses while opening or closing the freezer lid.
Health Sensor Error	The error that occurs when the freezer temperature rises above +10 degrees F.
Vacuum Out Of Order	The error that occurs when the robot makes 3 unsuccessful attempts to vend product (vacuum seal is lost/product dropped) on 3 consecutive bins (9 consecutive vacuum related Bin Errors= Vacuum Out of Order).

Product Sensor Error	The error that occurs when the product sensor switch reads open during the vend cycle.
Out Of Product	The error that occurs when the robot reaches the “Virtual Bottom” of every bin or selection in the entire machine indicating that there is no product. The Controller determines the “Virtual Bottom” by calculating encoder pulses as the robot drops hose into the bin.
<p>*Only one Fatal Error is logged in the VAC for any given vend cycle. The Fatal Error that initially puts the machine out-of-order is generally the error that is logged and displayed in the VAC (exception: Stuck Motor Errors will take precedence over Encoder Errors).</p>	

ORDER OF OPERATION

SOFTWARE	
1	Initiating The Vend Cycle
	<ul style="list-style-type: none">▶ Credits are calculated and registered by the control board.▶ Freezer door raises to its full open position.▶ A selection is accepted from the customer keypad. ▶ Vend cycle starts from the Home Position moves on the X-axis first: 2B.▶ Vend cycle starts from the Drop Point 2A.

2a	Robot Moves On The Y-Axis (Vend Cycle Starting From The Product Drop Point)
	<ul style="list-style-type: none">▶ The F/B Motor moves the robot back a predetermined distance on the Y-axis in order to avoid structural obstacles at the front of the machine near the Product Drop Point. ▶ The controller counts encoder pulses relayed by the F/B Encoder Switch. <i>If:</i><ul style="list-style-type: none">• Encoder pulses are not seen for a period of time causing the robot to return to the Home Position.<ul style="list-style-type: none">○ The robot moves to the Home Position on the X-axis then the Y-axis.○ The customer is prompted: "Make Another Selection".○ The next vend cycle starts from the Home Position. • The robot is not able to return to the home position after the F/B Encoder times out.<ul style="list-style-type: none">○ F/B Stuck Motor is flagged and recorded in the VAC log.○ The machine is put out-of-order. ▶ The robot stops once it reaches the default encoder count.

2b	Robot Moves On The X-Axis To Bin
	<ul style="list-style-type: none">▶ The LR Motor moves the robot to the right on the X-axis, ▶ The controller counts encoder pulses relayed by the L/R Encoder Switch. <i>If:</i><ul style="list-style-type: none">• Encoder pulses are not seen for a period of time, the robot will attempt to return to the Home Position.<ul style="list-style-type: none">○ The robot moves to the Home Position on the Y-axis then the X-axis.○ The customer is prompted: "Make Another Selection".○ The next vend cycle starts from the Home position • The robot has 3 consecutive failed attempts at vending any selection(s)<ul style="list-style-type: none">○ The machine is put out-of-order with a L/R Encoder Error (VAC) • Encoder pulses are not seen for a period of time and the robot times out before reaching the Home Position.<ul style="list-style-type: none">○ The machine is put out-of-order with a L/R Stuck Motor (VAC)○ The machine is put out-of-order. ▶ The robot stops once it reaches the selection's X-coordinate.

3	<p>Robot Moves On The Y-Axis To Bin</p>
	<p>▶ The F/B Motor begins to move the robot on the Y-axis</p> <p>▶ The controller counts encoder pulses relayed by the F/B Encoder Switch.</p> <p><i>If:</i></p> <ul style="list-style-type: none"> • Encoder pulses are not seen for a period of time, the robot will attempt to return to the Home Position. <ul style="list-style-type: none"> ○ The robot moves to the Home Position on the X-axis then the Y-axis. ○ The customer is prompted: "Make Another Selection". ○ The next vend cycle starts from the Home position • The robot has 3 consecutive failed attempts at vending any selection(s) <ul style="list-style-type: none"> ○ The machine is put out-of-order with a F/B Encoder Error (VAC) • Encoder pulses are not seen for a period of time and the robot times out before reaching the Home Position. <ul style="list-style-type: none"> ○ The machine is put out-of-order with a F/B Stuck Motor (VAC) <p>▶ The robot stops once it reaches the selection's Y-coordinate and is centered over the bin.</p>

4	<p>Robot Moves Down On The Z-Axis (Robot Is Over The Bin)</p>
	<p>▶ The U/D Motor moves the picker head down the Z-axis</p> <p>▶ The controller counts encoder pulses relayed by the U/D Encoder Switch.</p> <p><i>If:</i></p> <ul style="list-style-type: none"> • Encoder pulses are not seen for a period of time, the robot will attempt to return to the Home Position. <ul style="list-style-type: none"> ○ The machine is put out-of-order with an U/D Encoder Error (VAC) <p>▶ The controller monitors for an open signal from the product sensor (signifying contact with product).</p> <p><i>If:</i></p> <ul style="list-style-type: none"> • The controller does not detect the product sensor, the U/D Motor will continue to lower the picker head and unreach the hose. <ul style="list-style-type: none"> ○ The controller counts encoder pulses on the way down to determine how far it is from the virtual "bin bottom" ○ If the "bin bottom" Z-coordinate is reached, the robot will return to the Home Position, ○ The bin is put out-of-order with an Out Of Product Error. ○ The customer is prompted: "Make Another Selection". ○ If all bins in the machine are out of product, the machine will be put out-of-order with an Out Of Product error (VAC). <p>▶ Vacuum Motor turns on. The flap in the vacuum valve assembly rises to the up position, closing the reed switch.</p>

Robot Moves Up On The Z-Axis
(Robot Retrieves Product/A Vacuum Seal Is Created)

5

- ▶ **The open product sensor indicates that the robot has product and stops the U/D Motor from lowering the picker head and unreeling the hose.**
- ▶ **The open product sensor signal turns on the vacuum and activates the U/D Motor, lifting the picker head up the Z-axis (after a 1 sec. delay)**
- ▶ **The robot reaches the full up position causing the U/D Guide to collapse and trigger the Z-Home Switch.**
If:
 - The controller times out before a closed U/D Home Switch signal is detected.
 - The vacuum motor is shut down.
 - The machine is put out-of-order with an UD Motor Stuck Error (VAC).
- ▶ **The controller monitors for a closed reed switch on the vacuum valve assembly, indicating dropped product (airflow box flap in the down position caused by a break in the vacuum seal).**
If:
 - The robot returns to the Z-axis home position and reattempt to complete the vend cycle up to 3 times.
 - The robot will go to the home position before making the third attempt.
 - 3 unsuccessful attempts will put the bin out-of-order with a Bin Load Error.
 - The customer is prompted: "Make Another Selection".
 - The machine is put out-of-order with a Vacuum Out Of Order Error (VAC), after 9 consecutive vacuum errors (3 bins out of order due to loss of product).

Robot Moves On The X-Axis To Drop Point

6

- ▶ **The LR motor moves the robot towards the calculated Product Drop Point coordinate on the X-axis.**
 - The robot will move back a default distance before continuing on the X-axis, if the bin location is near the gusset zone (front left and right corners of the cabinet).
- ▶ **The controller counts encoder pulses relayed by the L/R Encoder Switch.**
If:
 - Encoder pulses are not seen for a period of time, the robot will attempt to return to the Home Position.
 - The robot moves to the Home Position on the Y-axis then the X-axis.
 - The customer is prompted: "Make Another Selection".
 - The next vend cycle starts from the Home Position
 - The robot has 3 consecutive failed attempts at vending any selection(s)
 - The machine is put out-of-order with a L/R Encoder Error (VAC)
 - Encoder pulses are not seen for a period of time and the robot times out before reaching the Home Position.
 - The machine is put out-of-order with a L/R Stuck Motor (VAC)
 - The machine is put out-of-order.
- ▶ **The controller monitors for a closed reed switch on the vacuum valve assembly, indicating dropped product (airflow box flap in the up position caused by a break in the vacuum seal).**
If:
 - The robot returns to the Z-axis home position and reattempt to complete the vend cycle up to 3 times.
 - The robot will return to the bin and try to pick up product.
 - 3 unsuccessful attempts put the bin out-of-order with a Bin Error.
 - The customer is prompted: "Make Another Selection".

- The machine is put out-of-order with a Vacuum Out Of Order Error (VAC), after 9 consecutive vacuum errors (3 bins out of order due to loss of product).

▶ The robot stops once it reaches the calculated Product Drop Point coordinate on the X-axis.

7	<p style="text-align: center;">Robot Moves On The Y-Axis To Drop Point</p> <p>▶ The F/B Motor moves the robot to towards the calculated Product Drop Point coordinate on the Y-axis.</p> <p>▶ The controller counts encoder pulses relayed by the F/B Encoder Switch.</p> <p><i>If:</i></p> <ul style="list-style-type: none"> ▪ Encoder pulses are not seen for a period of time, the robot will move straight back, returning to the Y-Home Position located at the front of the cabinet. <ul style="list-style-type: none"> ○ The robot will retry to deliver product up to 3 times in a row. ▪ The robot has 3 unsuccessful attempts at reaching the drop point and completing the vend cycle. <ul style="list-style-type: none"> ○ The machine is put out-of-order with a F/B Encoder Error (VAC) <p>▶ The controller monitors for a closed reed switch on the vacuum valve assembly indicating dropped product (airflow box flap in the down position caused by a break in the vacuum seal).</p> <p><i>If:</i></p> <ul style="list-style-type: none"> ▪ The robot returns to the Y-axis home position and reattempts to complete the vend cycle up to 3 times. <ul style="list-style-type: none"> ○ The robot will return to the bin and try to pick up product. ○ 3 unsuccessful attempts will put the bin out-of-order with a Bin Load Error. ○ The customer is prompted: "Make Another Selection". ○ The machine is put out-of-order with a Vacuum Out Of Order Error (VAC), after 9 consecutive vacuum errors (3 bins out of order due to loss of product). <p>▶ The robot stops once it reaches the calculated Product Drop Point coordinate on the X-axis.</p> <p>▶ The robot carriage moves forward on the rack system, and mechanically triggers the blow off valve crank, releasing all the vacuum pressure from the system.</p> <p>▶ The Vacuum Motor shuts down</p> <p>▶ Product is dropped into the product delivery chute.</p>
----------	---

8	<p style="text-align: center;">The Vend Cycle Is Complete The Machine Is Ready For Another Vend Cycle</p> <p>▶ Any change owed to the customer is calculated and dispensed.</p> <p>▶ The freezer lid is closed (If not in line mode).</p> <p>▶ The vend sequence is complete and the machine is ready for another vend.</p> <ul style="list-style-type: none"> ▪ The next three vend cycles will be initiated from this drop point position. ▪ The robot returns to true home after ever 4 vends to reorient itself for accuracy.
----------	---

TROUBLESHOOTING CHARTS

Always troubleshoot using logical, progressive steps so that the maintenance and repair procedure runs smoothly and efficiently. Most failures may have minor causes such as loose connectors or dirty contacts. Always check the following before replacing any parts:

- Check that all the plugs and connections are seated firmly in their receptacles (connector pins are not bent or broken).
- Check that there is continuity in the wires.
- Check that the connector pins are not bent or broken.
- Check the fuse(s).

Left/Right Stuck Motor		
Note: The machine has dynamic breaking features that make it difficult to move the robot manually when power is on. To move the robot, use the Left, Right, Forward, Back buttons on the Service Keypad or disable the dynamic breaking feature by shutting the machine off before attempting to move the robot manually.		
Detail	Possible Cause	Action/Solution
Manually move the robot to the right 6" and press the reset button. If the robot moves left towards the home position ►	Faulty L/R home switch	The L/R Home switch must be replaced.
	Loose or bad connection from the controller board to the L/R home switch.	Perform a continuity check from the computer board J5 connector (pins 7 & 8) to the L/R home switch. Find the loose or bad connection.
	Faulty computer board	Replace the computer board
Manually move the robot to the right 6" and press the reset button. If the robot does not move left towards the home position ►	Broken teeth or gear binding at the L/R motor and rack if it sounds like it is attempting to move.	Fix the cause of the binding and/or replace broken gears.
	Loose or bad connection from the computer board to the L/R Motor.	Perform a continuity check from the computer board J18 connector (pins 10 & 12) to the L/R Motor. Find the loose or bad connection.
	Blown or faulty fuse	Replace the fuse in the power box.
	Faulty Motor	Replace the L/R motor.
	Faulty MOSFET on computer board	Replace the computer board
	Faulty computer board	Replace the computer board

F/B Stuck Motor		
Detail	Possible Cause	Action/Solution
Manually move the robot forward 6" and press the reset button. If the robot moves back towards the home position ►	Faulty F/B home switch	The F/B Home switch must be replaced.
	Loose or bad connection from the controller board to the F/B home switch.	Perform a continuity check from the computer board J10 connector (pins 5 & 6) to the F/B home switch. Find the loose or bad connection.
	Faulty computer board	Replace the computer board
Manually move the robot forward 6" and press the reset button. If the robot does not move back towards the home position ►	Broken teeth or gear binding at the F/B motor and rack if it sounds like it is attempting to move.	Fix the cause of the binding and/or replace broken gears.
	Loose or bad connection from the computer board to the F/B Motor.	Perform a continuity check from the computer board J18 connector (pins 7 & 9) to the F/B Motor. Find the loose or bad connection.
	Blown or faulty fuse	Replace the fuse in the power box.
	Faulty Motor	Replace the F/B motor.
	Faulty MOSFET on computer board	Replace the computer board
	Faulty computer board	Replace the computer board

U/D Stuck Motor		
Detail	Possible Cause	Action/Solution
Manually pull the Hose down 6" and press the reset button. If the robot moves up towards the U/D home position ►	Short bin programmed as a tall bin	Reprogram and edit selection.
	Faulty U/D home switch	The U/D Home switch must be replaced.
	Loose or bad connection from the controller board to the U/D home switch.	Perform a continuity check from the computer board J5 connector (pins 3 & 4) to the U/D home switch. Find the loose or bad connection.
	Faulty computer board	Replace the computer board
Manually pull the Hose down 6" and press the reset button. If the robot does not move up towards the U/D home position ►	Loose or bad connection from the computer board to the U/D Motor.	Perform a continuity check from the computer board J18 connector (pins 4 & 6) to the U/D Motor. Find the loose or bad connection.
	Blown or faulty fuse	Replace the fuse in the power box.
	Faulty Motor	Replace the U/D motor.
	Faulty MOSFET on computer board	Replace the computer board
	Faulty computer board	Replace the computer board

Freezer Close Stuck Motor		
Detail	Possible Cause	Action/Solution
Press "Load". If the freezer door raises towards the open position ►	Faulty freezer open switch	The freezer open switch must be replaced.
	Loose or bad connection from the controller board to the freezer open switch.	Perform a continuity check from the computer board J10 connector (pins 4 & 5) to the freezer open switch. Find the loose or bad connection.
	Faulty computer board	Replace the computer board
Press "Load". If the freezer door does not raise towards the open position ►	Faulty freezer open switch	The freezer open switch must be replaced.
	Loose or bad connection from the computer board to the freezer door Motor.	Perform a continuity check from the computer board J18 connector (pins 1 & 3) to the freezer door motor. Find the loose or bad connection.
	Blown or faulty fuse	Replace the fuse in the power box.
	Faulty Motor	Replace the freezer door motor.
	Faulty MOSFET on computer board	Replace the computer board
Faulty computer board	Replace the computer board	

Freezer Open Stuck Motor		
Detail	Possible Cause	Action/Solution
Press "Load". Press "Close". If the freezer door lowers towards the close position ►	Faulty freezer close switch	The freezer close switch must be replaced.
	Loose or bad connection from the controller board to the freezer close switch.	Perform a continuity check from the computer board J10 connector (pins 1 & 2) to the freezer close switch. Find the loose or bad connection.
	Faulty computer board	Replace the computer board
Press "Load".	Faulty freezer close switch	The freezer open switch must be replaced.

If the freezer door does not raise towards the open position ►	Loose or bad connection from the computer board to the freezer door Motor.	Perform a continuity check from the computer board J18 connector (pins 1 & 3) to the freezer door motor. Find the loose or bad connection.
	Blown or faulty fuse	Replace the fuse in the power box.
	Faulty Motor	Replace the freezer door motor.
	Faulty MOSFET on computer board	Replace the computer board
	Faulty computer board	Replace the computer board

L/R Encoder Error

Note: All Encoder Switches are connected to their respective motor. To replace a faulty Encoder Switch, the motor must also be replaced.

Detail	Possible Cause	Action/Solution
Initiate a vend cycle. If the robot moves to the right ►	Loose or bad connection from the computer board to the L/R encoder switch. The robot will typically jerk towards the right if encoder pulses are not seen.	Perform a continuity check from the computer board J5 connector (pins 15, 16 & 17) to the L/R encoder Switch in the L/R Motor. Find and fix the loose or bad connection.
	Faulty encoder switch in the L/R Motor.	Replace the L/R Motor
	Faulty computer board	Replace the computer board
Initiate a vend cycle. If the robot does not move to the right ►	Loose or bad connection from the computer board to the L/R motor.	Perform a continuity check from the computer board J18 connector (pins 10 & 12) to the L/R Motor. Find and fix the loose or bad connection.
	Blown or faulty fuse	Replace the fuse in the power box.
	Faulty Motor	Replace the L/R motor.
	Faulty MOSFET on computer board	Replace the computer board
	Faulty computer board	Replace the computer board

F/B Encoder Error		
Detail	Possible Cause	Action/Solution
Initiate a vend cycle. If the robot moves forward ►	Loose or bad connection from the controller board to the F/B encoder switch. The robot will typically jerk towards the right if encoder pulses are not seen.	Perform a continuity check from the computer board J5 connector (pins 12, 13 & 14) to the F/B encoder Switch in the L/R Motor. Find and fix the loose or bad connection.
	Faulty encoder switch in the F/B Motor.	Replace the F/B Motor
	Faulty computer board	Replace the computer board
Initiate a vend cycle. If the robot does not move forward ►	Loose or bad connection from the computer board to the F/B motor.	Perform a continuity check from the computer board J18 connector (pins 7 & 9) to the F/B Motor. Find and fix the loose or bad connection.
	Blown or faulty fuse	Replace the fuse in the power box.
	Faulty Motor	Replace the F/B motor.
	Faulty MOSFET on computer board	Replace the computer board
	Faulty computer board	Replace the computer board

U/D Encoder Error		
Detail	Possible Cause	Action/Solution
Initiate a vend cycle. If the robot move moves down ►	Loose or bad connection from the controller board to the U/D encoder switch. The robot will typically jerk towards the right if encoder pulses are not seen.	Perform a continuity check from the computer board J5 connector (pins 9, 10 & 11) to the U/D Encoder Switch in the U/D Motor. Find and fix the loose or bad connection.
	Faulty encoder switch in the U/D Motor.	Replace the U/D Motor
	Faulty computer board	Replace the computer board
Initiate a vend cycle. If the robot does not move down ►	Loose or bad connection from the computer board to the U/D motor.	Perform a continuity check from the computer board J18 connector (pins 4 & 6) to the U/D Motor. Find and fix the loose or bad connection.
	Faulty Motor	Replace the U/D motor.
	Faulty MOSFET on computer board	Replace the computer board
	Faulty computer board	Replace the computer board

Out Of Product		
Detail	Possible Cause	Action/Solution
Check for product in bins ►	Tall bin was programmed as a short bin.	Reprogram and edit selection.
	Bins Out of Product	Refill

Vacuum Out Of Order		
Detail	Possible Cause	Action/Solution
Initiate a vend cycle. If the vacuum turns on ►	Not enough voltage going to the machine to pick up product.	Plug the machine into a better outlet or unplug anything that may be sharing the same outlet.
	There is a hole in the hose	Locate and replace the damaged hose (88”).
	Loose or bad connection from the controller board to the vacuum valve switch.	Perform a continuity check from the computer board J5 connector (pins 6 & 7) to the vacuum valve switch. Find and fix the loose or bad connection.
	There is debris in the vacuum valve box.	Clear out any obstruction.
	Mechanical binding in the vacuum valve flap mechanism	Open the Vacuum Valve box and fix the cause of the binding.
	Binding of the blow off actuator arm	
	Faulty Vacuum Valve reed switch	Replace the faulty Vacuum Valve reed switch
Initiate a vend cycle. If the vacuum does not turn on ►	Blown or faulty fuse	Replace the 10 amp fuse on the single triac board.
	Loose or bad connection from the computer board to the vacuum motor.	Perform a continuity check from the computer board J4 connector (pins 1 & 12) to the single triac board. Then from the single triac board J5 (pins 1 & 3) to the vacuum motor. Find and fix the loose or bad connection.
	Faulty single triac boards	Replace the single triac board
	Faulty vacuum motor	Replace the vacuum motor
	Faulty computer board	Replace the computer board

Bin Errors		
Detail	Possible Cause	Action/Solution
Initiate multiple vend cycles. If the robot is drops product ►	Hole in the product bag	Remove
	Air leak in hose	Replace hose
	Distorted or hole in the Picker tip	Replace picker tip
	Programming and/or bin alignment.	Check and reprogram bins so that the robot drops straight down the center of the bin.
	Machine is not level so the Picker head is not centered on the product causing an improper vacuum seal.	Level the machine.
	Blow off flapper in a slightly open position due to deformed gasket	Replace neoprene blow off valve gasket
	Binding in the Vacuum Valve Assembly	Inspect the assembly and fix the cause of the binding.

Vacuum Problems		
Detail	Possible Cause	Action/Solution
Initiate multiple vend cycles.	Blockage or obstruction anywhere between the picker tip and the vacuum valve assembly.	Remove blockage
Robot drops down approx 5", comes up without getting product and ► proceeds to the product drop point to complete the vend cycle. Acts as if there was a successful vend cycle.	Magnetic reed switch in the vacuum valve assembly is faulty.	Replace the Magnetic Reed switch
	Loose or bad connection from the controller board to the vacuum switch.	Perform a continuity check from the computer board J5 connector (pins 6 & 7) to the vacuum switch in the Vacuum Valve. Find and fix the loose or bad connection.