

# AP Product Manual

**AUTOMATIC PRODUCTS**  
International, Ltd.  
A Higher Standard.



# PREMIER® 130 SERIES

**SET-UP and INSTALLATION**

**OPERATING SYSTEM**

**TROUBLESHOOTING**

**PARTS**

**PLEASE**

**DO NOT REMOVE  
MANUAL FROM  
MACHINE**

**Automatic Products int'l Ltd. ♦ 75 W. Plato Blvd. ♦ St. Paul MN 55107**



## TABLE OF CONTENTS

Warranty .....	ii
Introduction.....	iii
Features .....	iv
Specifications .....	v
Installation .....	1.01
Cautions .....	1.01
Unpacking .....	1.02
Leveling the Machine .....	1.02
Door Hinge .....	1.03
Set Up Steps .....	1.04
Optional Equipment.....	2.01
Refrigeration.....	2.02
Components .....	3.01
Power Supply .....	3.01
Lighting System.....	3.01
Main Product Shelves .....	3.01
Delivery Bin .....	3.01
Vend Motors.....	3.02
Logic Board & Display .....	3.03
Keypad .....	3.03
Coin Mechs, Validators and Card Readers .....	3.04
Golden Eye®.....	3.05
Operating System.....	4.01
Power Up State .....	4.01
Motor Scan .....	4.01
Standby .....	4.01
Keypad .....	4.01
Credit Accumulation .....	4.01
Vend Process.....	4.02
Change Payback .....	4.02
Use Correct Change .....	4.02
Token Vends .....	4.02
Accountability Information .....	4.02
Shutdowns.....	4.02
DEX/UCS .....	4.02
Programming.....	5.01
Service Modes.....	5.03
Parts.....	6.01
Service/Trouble Shooting .....	7.01

To achieve the most trouble-free operation from your 130 Series Merchandiser, it is highly recommended that this service manual be thoroughly read and the instructions followed pertaining to installation, servicing and maintaining of the unit.

Should you have questions pertaining to this manual or the vendor, please contact your APi distributor or write directly to:

Product Support Group  
Automatic Products int. Ltd.  
75 West Plato Blvd.  
St. Paul, MN. 55107 USA  
651-224-4391  
651-393-4538 (fax)

© 2005 Automatic Products international, Ltd

## LIMITED EXPRESS WARRANTY

Automatic Products International, Ltd. (API) warrants these automatic merchandisers (the "Unit"), manufactured by it, to be free under normal use and service from defects in material or workmanship for a period of two (2) years from the date of delivery of this Unit to the original purchaser who purchased the Unit either directly from API or from an authorized API dealer or distributor ("API Dealer/Distributor"). This warranty extends only to the original purchaser of the Unit, but only if purchased either directly from API or from an authorized API Dealer/Distributor ("Original Purchaser"), and is limited to the repair or replacement, at API's sole option, of any part or parts of the Unit that are returned to API or to the authorized API Dealer/Distributor from whom the Unit was originally purchased, with all transportation charges prepaid by Original Purchaser, and which, on API's examination, such returned part or parts shall conclusively appear to have been defective. This warranty does not extend to:

1. Any Unit, or part thereof, that was subjected to misuse, neglect, or accident by anyone other than API after its delivery to the Original Purchaser;
2. Any Unit, or part thereof, that was modified, altered, incorrectly wired or improperly installed by anyone other than API or used in violation of the instructions provided by API;
3. A Unit, or part thereof, which has been repaired or altered by anyone other than API or an authorized API Dealer/Distributor;
4. A Unit, or part thereof, which has had the serial number removed, defaced, or otherwise altered;
5. Any plastic or glass windows, lamps, fluorescent tubes, and water contact parts;
6. Any Unit used outdoors;
7. Any accessories used with the Unit that were manufactured by some person or entity other than API; or
8. Any Unit repaired within the warranty period with parts other than genuine API built or endorsed parts.

**API DISCLAIMS ALL OTHER WARRANTIES OF ANY KIND AS TO THE UNIT AND ALL WARRANTIES OF ANY KIND AS TO ANY ACCESSORIES. THIS DISCLAIMER OF WARRANTIES INCLUDES (1) ANY EXPRESS WARRANTIES OTHER THAN THE LIMITED WARRANTY PROVIDED ABOVE AS TO THE UNIT AND (2) ALL IMPLIED WARRANTIES OF MERCHANTABILITY AND FITNESS FOR A PARTICULAR PURPOSE AS TO THE UNIT AND ANY ACCESSORIES. UNDER NO CIRCUMSTANCES SHALL API BE RESPONSIBLE FOR ANY INCIDENTAL, CONSEQUENTIAL OR SPECIAL DAMAGES, LOSSES OR EXPENSES (INCLUDING BUT NOT LIMITED TO LOST PROFITS, LOST SALES, INJURY TO PERSON OR PROPERTY) ARISING FROM OR IN CONNECTION WITH THE USE OF, OR THE INABILITY TO USE, THE UNIT FOR ANY PURPOSE WHATSOEVER REGARDLESS OF THE LEGAL THEORY (CONTRACT, TORT OR OTHER). IN NO EVENT WILL API BE OBLIGATED TO PAY DAMAGES FOR ANY AMOUNT EXCEEDING THE PRICE PAID FOR THE UNIT.** No representative of API or any other person is authorized to assume for API, or agree to on the behalf of API, any other liability or warranty in connection with the sale of this Unit.

API reserves the right to make any changes or improvements in its products without notice and without obligation, and without being required to make corresponding changes or improvements in Units theretofore manufactured or sold.



A Higher Standard.

75 West Plato Blvd.  
St. Paul, MN. 55107 USA  
651-224-4391  
651-224-5559 (fax)

## INTRODUCTION

The 130 Series features simple operation and built in flexibility, as well as extensive diagnostics and error reporting facilities to provide ease of maintenance.

## HOW TO USE THIS MANUAL

This manual is divided into seven basic parts:

1. Unpacking and Installation.
2. Optional Equipment & Refrigeration
3. Components and Refrigeration.
4. Operating System.
5. Programming
6. Parts
7. Troubleshooting.



**CAUTION:** Certain procedures in both the operating section and the service section require that voltage be on in the machine. Only, trained personnel should perform this function. Exercise extreme caution while performing these procedures. These procedures will be marked with the lightening bolt symbol as it appears at left.



**CAUTION:** Certain procedures in both the operating section and the service section require a qualified trained technician to perform the particular task at hand. These procedures will be marked with the exclamation symbol as it appears at left.

1	3	3	C	0	5	3	6	5	0	0	1
↑			↑			↑			↑		
						Numerical day of the year – Jan 1 <sup>st</sup> = 001, Dec 31 = 365.			Sequential build number Starts at 001 every day.		
Year 01 – Last two digits of the year.											
First digits indicate model. Example shown is a 133C (133 with chiller) Glassfront Merchandiser – The machine identification may contain up to six characters dependent upon the model.											
<b>Suffixes</b>											
C – Indicates a chilled machine.											
E – Indicates a machine built specifically for export outside of North America.											

**Serial Number Identification Chart**

# Features

---

## FEATURES OF THE 130 MERCHANDISER

### STANDARD FEATURES

- Up to 100 selections.
- Multi drop buss capabilities (MDB).
- Extensive diagnostics capabilities.
- Friendly text-based interface.
- Flexible spiral spacing for large products.
- Eight-point star drive motor.
- Dex/UCS compatible.
- Food/Frozen hosting.
- Real time clock.
- Machine reset capability.
- Chime.

### PRICING

- Global pricing by machine or by shelf.
- Extensive accountability, including all discounts and free vends.
- Shutdown capabilities
- Combo vends.
- Programmable spiral count.
- Upload and download capabilities for pricing and set up.
- Programmable maximum payout.

### SCROLLING DISPLAY

- User friendly two-line scrolling display to help with the selection process and provide customer feedback.
- User programmable point of sale and operational messages.
- 2 line display with 20 characters on each line.

### OPTIONS

- Point of sale window.
- Delivery bin cushion.
- Base kit.
- Lexan window.

### NOISE LEVEL

Operates at less than 70 db (A).

### ACCEPTABLE AMBIENT OPERATING TEMPERATURE RANGE.

All equipment manufactured by Automatic Products Intl. Ltd. Is designed to work properly in a temperature range of 10°C to 38°C (50°F to 100°F) in still air (75% R.H. non-condensing). The machine is being stored in a temperature range of -18°C to 68°C (0°F to 155°F).

# Specifications

Specifications	133 Domestic Ambient	133 Domestic Chilled	133 Export Ambient	133 Export Chilled
Height	72" / 183 cm	72" / 183 cm	72" / 183 cm	72" / 183 cm
Width	38.875" / 99 cm	38.875" / 99 cm	38.875" / 99 cm	38.875" / 99 cm
Depth	35" / 89 cm	35" / 89 cm	35" / 89 cm	35" / 89 cm
Floor Space	9.5 Sq. Ft./ .88 Sq Meter	9.5 Sq. Ft./ .88 Sq Meter	9.5 Sq. Ft./ .88 Sq Meter	9.5 Sq. Ft./ .88 Sq Meter
Container Size	72.5 Cu Ft./ 2.05 Cu Meter	72.5 Cu Ft./ 2.05 Cu Meter	72.5 Cu Ft./ 2.05 Cu Meter	72.5 Cu Ft./ 2.05 Cu Meter
Voltage (AC)	120V	120V	230V	230V
Hertz	60Hz	60Hz	50Hz	50Hz
Standby Amperes	0.7A	0.7A	.35A	.35A
Running Amperes	3A	12A	3A	6A
Watts	360W	1440W	345W	1380W
Refrigerant Type	N/A	134A	N/A	134A
Refrigerant Charge	N/A	9.0 oz / 0.25 Kg	N/A	9.0 oz / 0.25 Kg
High Side Test Pressure	N/A	230 psi	N/A	230 psi
Low Side Test Pressure	N/A	133 psi	N/A	133 psi
Shipping Weight	555 lbs / 222 kg	700 lbs / 318 kg	555 lbs / 252 kg	650 lbs / 295 kg

Specifications	131 Domestic Ambient	131 Domestic Chilled	131 Export Ambient	131 Export Chilled	132 Domestic Ambient	132 Domestic Chilled	132 Export Ambient	132 Export Chilled
Height	72" 183 cm				72" 183 cm			
Width	33.5" 88 cm				33.5" 88 cm			
Depth	27.625" 70.167 cm				35" 89cm			
Floor Space	6.4 Sq. Ft. .59 Sq Meter				8.1 Sq. Ft. .75 Sq Meter			
Container Size	45.5 Cu Ft. 1.29 Cu Meter				58.1 Cu Ft 1.65 Cu Meter			
Voltage (AC)	120V		230V		120V		230V	
Hertz	60Hz		50Hz		60Hz		50Hz	
Standby Amperes	0.7A		.35A		0.7A		.35A	
Running Amperes	3A	12A	1.5A	6A	3A	12A	1.5A	6A
Watts	360W	1440W	345W	1380W	360W	1440W	345W	1380W
Refrigerant Type	N/A	134A	N/A	134A	N/A	134A	N/A	134A
Refrigerant Charge	N/A	9.0 oz 0.255 Kg	N/A	9.0 oz 0.255 Kg	N/A	9.0 oz 0.255 Kg	N/A	9.0 oz 0.255 Kg
High Side Test Pressure	N/A	230 psi	N/A	230 psi	N/A	230 psi	N/A	230 psi
Low Side Test Pressure	N/A	133 psi	N/A	133 psi	N/A	133 psi	N/A	133 psi
Shipping Weight	440 lbs 200 kg	550 lbs 249 kg	440 lbs 200 kg	550 lbs 249 kg	495 lbs 225 kg	620 lbs 281 kg	495 lbs 225 kg	620 lbs 281 kg

# Specifications

<p style="text-align: center;"><b>131</b> <b>SNACK SPIRALS</b></p> <p>4 – Item Spiral 3” 6 – Item Spiral 2-3/32” 8 – Item Spiral 1-9/16” 10 – Item Spiral 1-7/32”</p>	<p style="text-align: center;"><b>131</b> <b>CANDY SPIRALS</b></p> <p>3 – Item Spiral 3-5/8” 4 – Item Spiral 2-15/16” 6 – Item Spiral 1-15/16” 8 – Item Spiral 1-1/2” 10 – Item Spiral 1-1/8” 12 – Item Spiral 15/16” 16 – Item Spiral 11/16” 20 – Item Spiral 1/2”</p>	<p style="text-align: center;"><b>132 &amp; 133</b> <b>SNACK SPIRALS</b></p> <p>5 - Item Spiral 4-1/8” 6 – Item Spiral 3-3/32” 7 – Item Spiral 2-21/32” 10 – Item Spiral 1-7/8” 12 – Item Spiral 1-9/16” 15 – Item Spiral 1-7/32” 18 – Item Spiral 1” 30 – Item Spiral 1/2” 40 – Item Spiral 5/16”</p>	<p style="text-align: center;"><b>132 &amp; 133</b> <b>CANDY SPIRALS</b></p> <p>5 – Item Spiral 4-1/8” 6 – Item Spiral 2-7/8” 7 – Item Spiral 2-1/2” 9 – Item Spiral 1-15/16” 10 – Item Spiral 1-3/4” 12 – Item Spiral 1-1/2” 15 – Item Spiral 1-1/8” 18 – Item Spiral 15/16” 24 – Item Spiral 11/16” 30 – Item Spiral 1/2” 40 – Item Spiral 3/16”</p>
---	---	--	--

## SPIRAL DEPTHS



# Installation

## Cautions

The following cautionary information should be reviewed before the machine is installed. Following these requirements and warnings are required.



**CAUTION:** This machine is designed for indoor usage only. Any other usage will void the Manufacturers Warranty.



### Voltage and Polarity Check

It is important that this machine is hooked up to the proper voltage and polarity for your country. Use a voltmeter to verify voltage and polarity before connecting the machine to a wall outlet. For machines located in North America, use the diagram below to verify correct voltages.



**CAUTION:** Any procedure marked with the symbol at left requires that the Machine have the power applied and a shock hazard exists.



**CAUTION:** It is important that this machine is hooked up to the proper voltage and polarity for your country. Use a Voltmeter to verify voltage and polarity. Should the reading be any different than a normal reading or if you are unsure of what the reading should be contact an electrician.



**CAUTION:** Different countries may have unique plug arrangements. Ensure that the machine is properly grounded before operating.



**CAUTION:** The power cord for all machines manufactured for use outside of North America are of a type Y attachment. If the power cord is damaged, it must be replaced by the manufacturer, its service agent, or a similarly qualified person in order to avoid a hazard.



**CAUTION:** The machine is a heavy item. Ensure that sufficient personnel are available for lifting and transporting the machine. Use proper lifting procedures and equipment.



ESD SENSITIVE

**CAUTION:** The system components in this machine utilize static sensitive components. Precautions for handling sensitive devices should be observed when handling these items.

## Voltage and Polarity Check (for Machines located in North America Only)

It is important that this machine is hooked up to proper voltage and polarity. Using a voltmeter, perform the following checks from the illustration below.

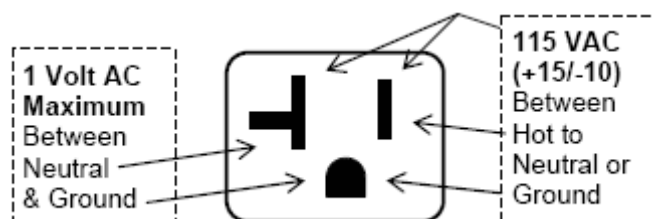

# Installation

The 130 Line is assembled and packed so that a minimum amount of time is necessary for preparation to install it on location. The following steps are recommended to insure correct unpacking.

1. **Shipping Damage:** Thoroughly inspect the exterior of the carton for damage which may have occurred during shipment. Report any damage to delivering carrier and follow their instructions.
2. Remove the remainder of the packing material. On machines shipped with the lock in place, the keys are taped inside the coin return.

**NOTE:** On the machine, the weight concentration is toward the back of the cabinet. Trucking and lifting should be done from the back. CAUTION should be taken when trucking from side.

3. On machines with lock in place, first unlock and turn handle to open door. When no lock is furnished, remove clip and turn handle. Swing door to its full open position.
4. Remove all additional packing material from the machine.
5. **Warranty:** The warranty card is attached to the cover of this manual. It must be filled out in full and mailed at once to insure coverage.

**Leveling the Machine** on location is important for the proper function of the machine. There are four leveling screws in the legs of the machine to make any necessary adjustments. After positioning the machine, level it from front to rear and right to left directions. After leveling, turn front right (lock side) leveling screw in about one-half turn to drop this corner slightly to make the door easier to close and lock.

## Clearance Requirements

It is necessary on 132 or 133 machines with thermal glass to have 3" clearance on the left side of the machine for the door to extend 3" past the cabinet side. All machines with chillers require 6" clearance behind the machine for air circulation.

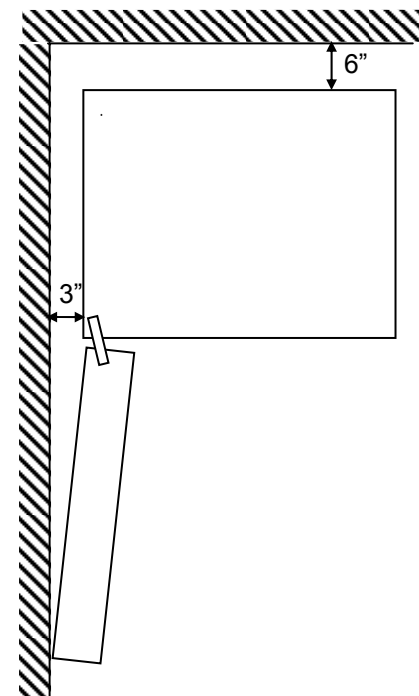
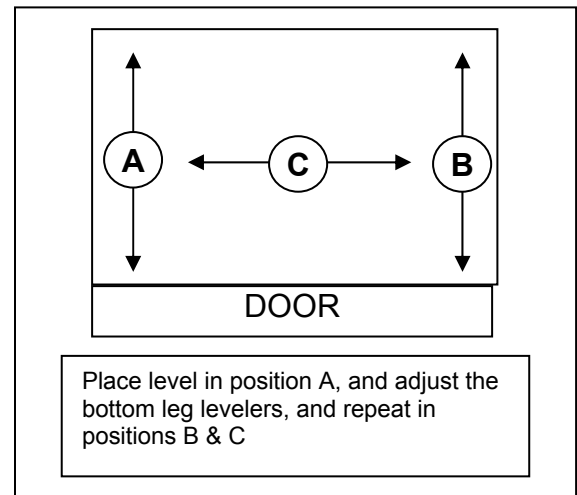

◆ **IMPORTANT:** A set of anchoring brackets is included with each machine. This kit is located in the bottom of the machine with complete instructions. It is recommended that this kit be installed during set-up to prevent shifting of the machine.

# Installation

## Door Hinge Swing

This machine contains a newly designed door hinge. The design of the door hinge controls the maximum distance the door can swing open. The maximum opening position is reached when the screw is forced against the hinge body. This screw can be removed during installation to permit the door to swing completely open and can help maneuver the machine through a narrow doorway.

The screw should be replaced **immediately** upon reaching the machine's final location. Failure to replace this screw may result in damage to an adjacent machine or to the harnesses in the machine.

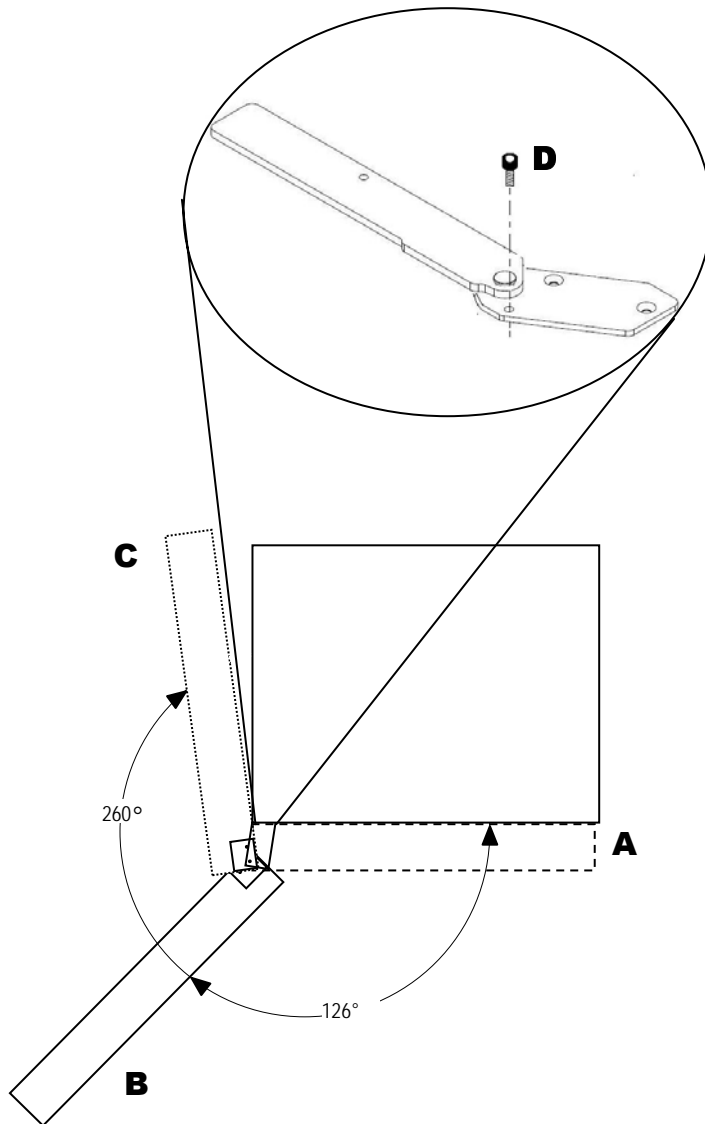

**Position A** – Door Closed.

**Position B** – Door open to nominal position with stop screw (D) installed.

**Position C** – Stop screw removed to permit door to reach maximum swing.



**CAUTION:** The screw should be replaced immediately upon reaching the machines final location. Failure to replace this stop may result in damage to an adjacent machine or the harnesses in the machine.

# Installation

## Basic Set Up Steps

1. Remove all packing materials.
2. Adjust the scrolling price tabs on the shelves.
3. Set prices and options on control board.
4. Set Clock.
5. Load machine adjust spacers or spirals as needed.
6. Install product pushers as needed.
7. Add coins to coin mechanism.
8. Coin test.
9. Bill test if applicable.
10. Install lock cylinder if needed.

## Loading Snack Shelves

Open the main door to its full open position. While pushing down on the plastic lock lever located on the right side of the shelf, grasp the shelf under both front corners (see Figure 1). Lift the front of the shelf slightly and pull forward until the shelf reaches its stop. On shelves 1 through 4 the shelves tilt down (do not drop) to make loading easier. A new feature in the 130 Series, the bottom 2 shelves do not tilt for easier loading. Only one product shelf should be in the loading position at any time. When returning a shelf, be sure the shelf is in its full home or vend position. Begin loading with the top shelf. Move it into the loading position. The height spacing for items is greatest in this shelf and the tallest bagged items should be placed there. Soft items, such as pastry, pies, etc., should be placed in the lowest snack shelf, making the drop distance as short as possible.

**IMPORTANT:** Product must not be forced into the spiral spaces it should fit freely. If a product fits tightly, use a larger pitch spiral. The bottom of the product should be placed on top of the spiral wire that rests on the shelf surface (see Figure 2). The width of the product must be greater than the diameter of the snack spiral. If it is smaller, the product may fall through when it is in the front, ready to vend position.



Figure 1: Moving shelf into the loading position

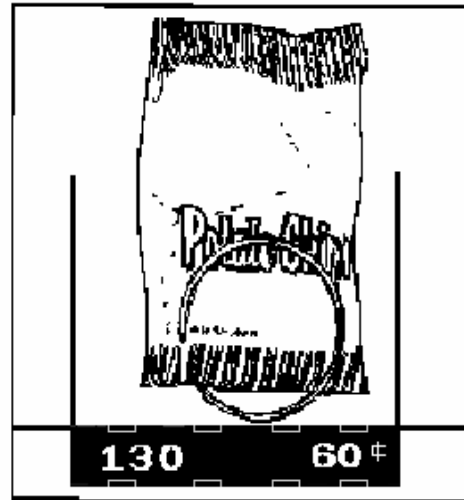

Figure 2: Placement of product on main product snack shelves and front end position of spiral.

# Installation

## Adjusting the Stopping Position of the Spiral

One primary difference that distinguishes the 130 motor from previous motors is an eight sided star at the drive hub of the motor. This permits the stopping position of the spiral to be customized by the operator to ensure the best possible delivery of each product. To change the stopping position of the spiral, remove the spiral lock from the motor by pinching the shaft of the spiral lock from the back side of the motor and pulling forward on the front side of the spiral lock.

The spiral lock can be reinstalled in any of eight different positions by turning the spiral lock to the position desired and pushing the shaft of the spiral lock through the eight sided star at the drive hub of the motor.

## Removal/Replacement of Spiral

Grasp the front of the spiral and turn it clockwise. Lift the spiral up and off of the spiral lock. When replacing a spiral attach it around the tab on the spiral lock and turn the spiral counterclockwise to lock it in place. Be sure the front end of the spiral is positioned properly (with the front end of the spiral pointing downward on the left side) (see figure 3). Pull lightly on the front of the spiral to ensure it is locked in place.

## Product Spacers - 5 Selection Shelf

A product spacer is used to reduce the width of the product area. This feature should be used on any 5-selection single spiral snack shelf where the product width is 4" or less. Spacers should fit within 1/8" of the product but should not fit tight against the product. There are three positions in each snack space where these spacers can be placed. To install the spacer, align the lock ears (on the lower edge of the spacer) with one of the three sets of slots (one front and one rear). (see Figure 4.) Push the spacer to the rear to allow the ears to enter the slots, then allow the spacer to move forward. Be sure the ears are in the same set of slots; front and rear (see Figure 4). Continue loading all spirals; adjust spacers where needed in the top shelf. Return the top shelf to the vend position and follow this procedure to load the remainder of the large spiral shelves.

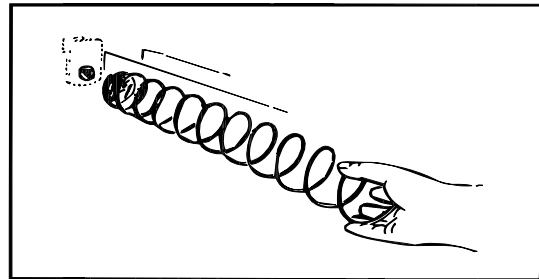

Figure 3: Removing and installing spiral.

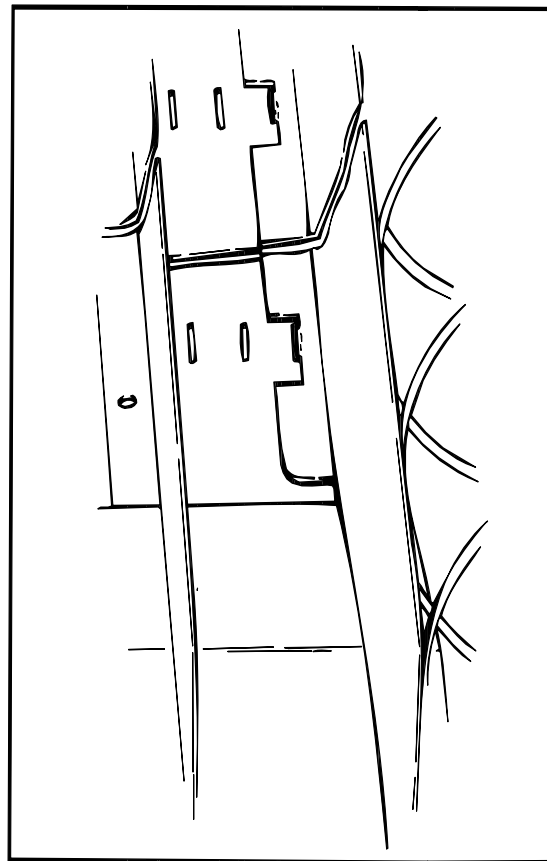

Figure 4: Alignment of movable product spacers.

# Installation

## Loading Main Product Candy Shelves

The 10-selection (candy type) shelves are loaded similarly to the 5-selection shelves except that the bottom of the product sits on the shelf in front of the spiral wire (see Figure 5). These products must also fit properly, and the product should fit freely: do not force product into spiral.

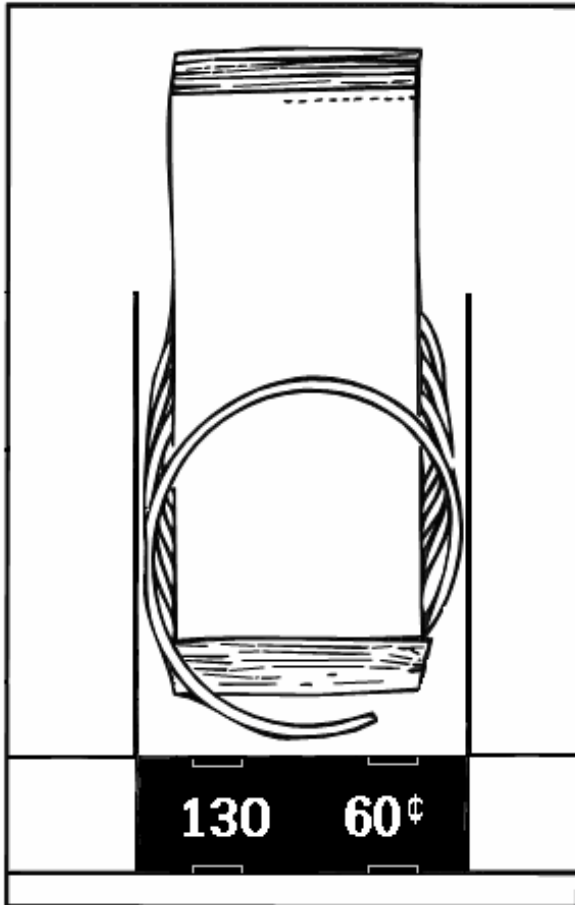

Figure 5: Placement of product on candy shelves and front end position of spiral.

## Product Spacers-10 Selection Shelf

The 10-selection shelves are equipped with a product spacer (see Figure 6) that can be pivoted from the right side of every other product space. These spacers should be pivoted out to hold the product upright, but not tight against the product. Leave about 1/8" clearance between the spacer and the product.

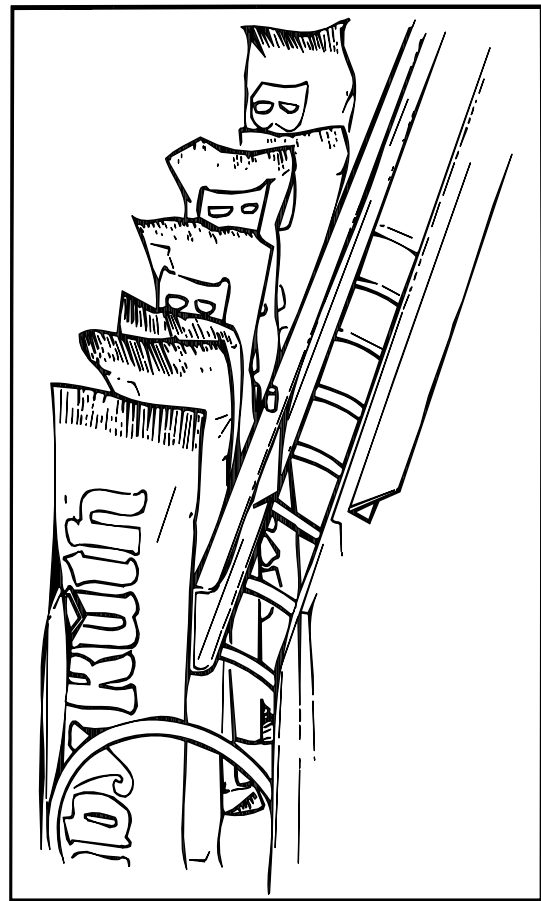
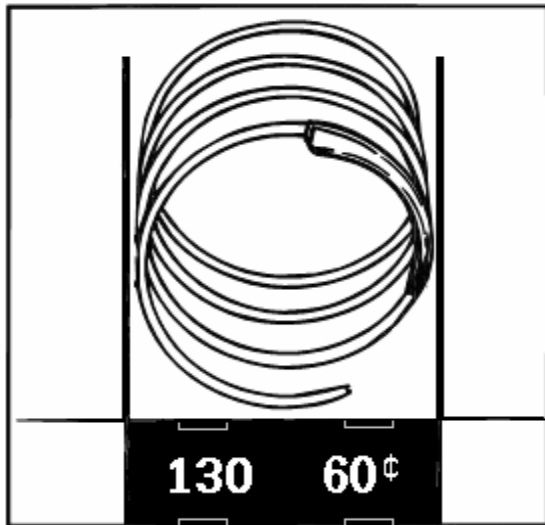

Figure 6: Candy shelf product spacer positioned to hold candy upright.

# Installation

## Product Pushers

Included with the machine are enough pushers for you to install a pusher on each candy spiral. This plastic part is designed to push the top of the product forward while it is vending, helping it fall from the shelf. It can also be used with products that have the wrapper end flap on the outside of the package. In this case, the pusher prevents these products from hanging on the spiral by spreading the flap. The pusher should be installed at approximately the 1 o'clock position on the spiral with the tab extending forward (see Figure 7). Locate the pusher in its proper position, hold it against the spiral wire and push the semi-circular part around the spiral wire. Black pushers (part #440215) are used on left hand spirals and white pushers (part #440141-1) are used on right hand spirals. Note: Not every selection spiral will need a product pusher. (Example - Box Items.)



**Figure 7: Location of product pusher on spiral.**

## Bagged or Boxed Items

Vending small bagged items in the 10-selection shelves if not loaded properly could be a problem. The sealed edge of the bag may get under the spiral wire causing the product to hang up after it has been vended. It is recommended that the lower edge of these types of product be folded forward and up (see Figure 8) next to the product before inserting into the spiral space. It is also recommended to use a slightly larger count spiral for bagged items because of the product settling to the bottom of the package.

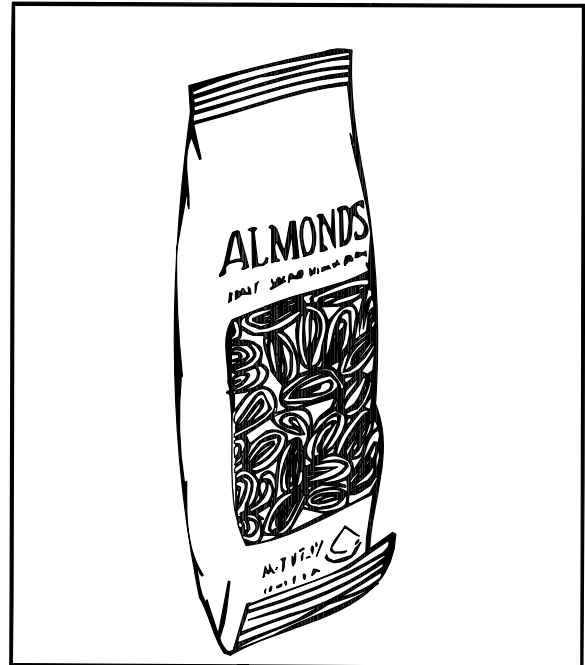

**Figure 8: Fold bagged items bottom edge forward and up.**

## Cigarette Vending from the 130 Series

Cigarettes can be vended from the candy shelves using a (15 capacity) spiral for the soft pack regular, king, 100 MM or 120 MM packs. A (12 capacity) spiral should be used for (box) packs.

## Lock Product Shelves

When all of the product has been loaded be sure all shelves are returned to their vend position behind the front roller guide.

## Scrolling Price Tabs

Adjust the new scrolling price roles for each selection in the machine.

# Installation

## Loading Gum and Mints

The optional Gum and Mint shelf is located below the lowest Snack Shelf. Unlatch the shelf by pulling forward on the metal latch located on the right of the shelf and pull forward. The cover can be pushed back to the rear for easy loading. The shelf contains four individual selections in a 131 and 132, and five selections in a 133.

The two selections on the right of the Gum and Mint shelf also have fillers. These selections can be used for standard size gum and mints or the fillers may be removed for larger gum and mint products.

Each selection has a display hinge assembly that should be adjusted after the shelf is loaded (see Figure 10). To adjust the display hinge, loosen the wing nut and slide the spring hinge of the flipper over the second product and fasten tightly.

- ◆ Be sure to close the cover on the gum and mint shelf before pushing the shelf back to its home position.
- ◆ The gum and mint shelf can be used as a loading platform while filling the machine. The maximum load of the gum and mints shelf is 35 pounds.

## Cleaning

The 130 series will do the best merchandising job for you if it is kept clean. The display window can be cleaned with any good glass cleaner. The exterior and interior surfaces should be cleaned with warm water and mild detergent. Rinse thoroughly and dry all surfaces.

**CAUTION:** Do not use any cleaners containing silicon as this could cause electrical failures.

The main product shelves can be best cleaned with the spirals and product spacers removed. Refer to page 1.05 for removal of spirals and removal of the product spacers.

Clean the acceptor on the coin mechanism or bill validator frequently as accumulated dirt in this area can cause poor acceptance on coins or bills. Follow recommended cleaning procedures as described by the coin mechanism or bill validator manufacturer.



**Figure 10: Correct gum and mint adjustment.**



# Optional Equipment

---

## **Ventilating Fan** (Part #750102-4 =120 Volts) (Part #750102-5 = 240 Volts) Export

This optional ventilating fan is only available when ordered from the factory with the hole in the rear of the cabinet. The fan keeps a steady flow of air moving through the vendor cabinet. Installation of the fan takes only a few minutes. All vendors are wired with a fan plug on the junction box for easy installation. Retrofit is not recommended for cabinets without the appropriate cutout

## **Base Kits**

Base kits are available to make the vendor compatible with other manufacturers.

## **Gum and Mint**

Gum and Mint units are available as an option with 130 Series vendors. Refer to this service manual for loading instructions and service instructions.

## **Dual Spiral Shelf**

Snack shelves can be set up to have dual spiral selections. The dual spirals will help vend specialty items better.

## **Half Cycle Motors**

The half cycle motors are used to vend thin items. This motor is used with a product divider that is positioned down the center of the coil. The product is placed on both the left and right hand side of the coil. When the motor turns, it turns only 180 degrees (half revolution) rather than 360 degrees (full revolution).

## **Delivery Bin Cushion**

A delivery bin cushion is available for use when vending heavy or fragile items.

## **Laminated Safety Glass Window**

A laminated safety glass window is available as a direct replacement for tempered glass.

## **Touch Memory Harness**

The touch memory harness (Part # 16800013) is used in conjunction with the touch memory button (CHIP) available separately (Part # 17500003). This harness will allow you to download all settable data, with the exception of the time and date. Once CHIP is programmed you can take it to as many machines as you wish to upload the information stored in CHIP. CHIP can be programmed from a machine that is already set up and then used to set up other machines that are to be programmed identically. For more information see Mode 30.

## **DEX/UCS Harness**

A chassis mount DEX harness (Part # 16800044) is available. This harness allows you to download the DEX information.

# Refrigeration

---

## 130 Series Chiller

### The Chiller Unit

The Chiller Unit is comprised of a 1/3 horsepower compressor and is a hermetically sealed system (no service ports). The compressor assembly is easily removed by taking out two screws and pulling the unit forward out the front of the cabinet. There is a wedge shaped insulator above the evaporator that mates with a matching wedge in the cabinet to ensure a tight seal. The refrigerant used in the refrigeration system is 134a and the charge is 9 ounces. The refrigeration system is controlled by the Refrigeration Driver Board. The 130 Series glassfront merchandisers are designed to operate at ambient temperature of 55°F to 100°F (13°C to 38°C). Chilled machines use a special insulated cabinet and a thermal pane window.

### Note

- ◆ The chiller can NOT be added at a later date.

### Refrigeration Processing:

The Refrigeration Driver Board (P/N 13600005-01) maintains the temperature as measured by the solid state temperature sensor. The chiller unit will be turned on at the set temperature plus 2°F and will be turned off at the set temperature minus 2°F. A minimum of 1 minute is required for both the cycle on and cycle off time of the relay. This insures the compressor is not cycled on and/or off too rapidly. Independent of the temperature, the relay, therefore the compressor, will be off 7 minutes every hour for a defrost cycle. The power for the Evaporator fan motor is constant and is not switched by the relay. The temperature probe in the 131, 132 and 133 is mounted in cabinet below the bottom shelf on the right hand side, just above the intake air of the evaporator.

## 130 Refrigeration (All)

### Refrigeration Driver Board (RDB)

The Refrigeration Driver Board (P/N 13600005-01) is located in the power supply box. The RDB has the capability to maintain two temperatures. Power and communication to operate the RDB is supplied via the MDB connector on the logic board using communications cable. Power to operate the refrigeration unit is supplied to the Refrigeration Driver Board immediately after the EMI filter and is switched on and off by a relay on the Refrigeration Driver Board. For a complete pin out of the Refrigeration Driver Board see the Troubleshooting Section of this manual.

### Settable Temperature Range

The settable temperature range is from 37°F to 80°F (3°C to 27°C). The recommended temperature for the 131, 132 and 133 machines is 65°F (18°C). The Refrigeration Driver Board will maintain the temperature as measured by the temperature probe (P/N 13600001-02). The harness for the probe is plugged onto the Refrigeration Driver Board at the connector marked JP3. An unplugged or open temperature sensor probe will display as -9°F (-9°C). A shorted probe will display as 99°F (37°C).

### Setting the Temperature

Refer to Service Mode 40 for the procedure to set the temperature.

# 320 Hosting

The 130 Series snack machine may be used to host a 320 Frozen/Refrigerated machine. The following steps should be followed.

1. **Check the software version of the food driver board. For the 320 to work properly with a 130 Series snack machine the food driver board must have Revision 1.9 or greater software. Arrow A in the diagram.**
2. Set the cabinet jumper to cabinet 2. Jumper B in diagram.
3. Set the refrigeration jumper to your desired setting, either frozen or refrigerated. Jumper C in diagram.
4. Plug the communications cable directly into the MDB plug on the 130 control board.
5. Set the temperature in Mode 40.
6. Set motor pairs if applicable in Mode 23.
7. Set the Golden Eye selections if applicable.
8. Set prices in Mode 20.

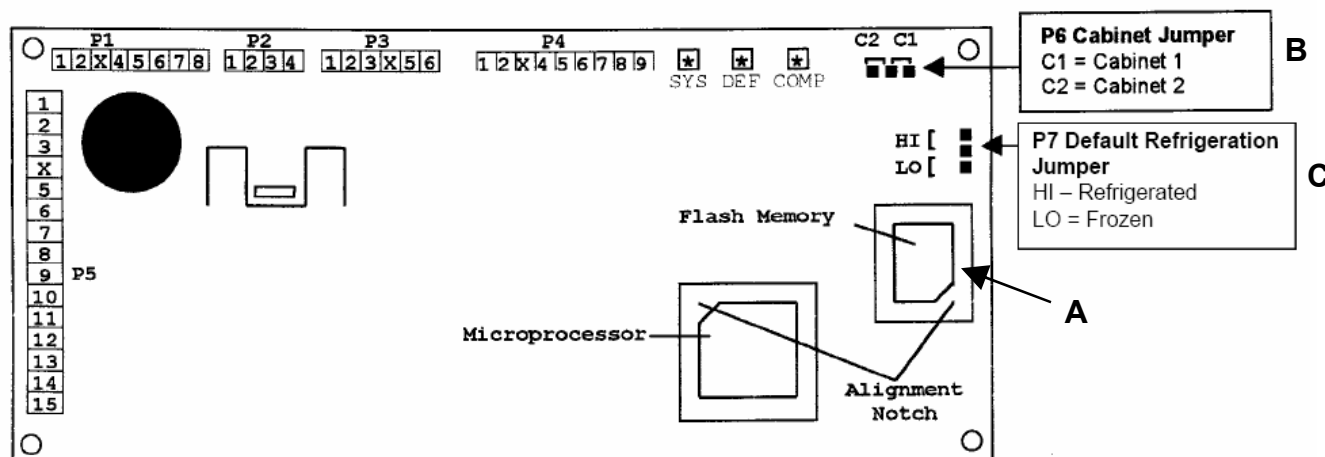

## SPECIAL INFORMATION

When a new Studio (ST) or 130 Series machine is used to host a Model 320 Á LA CARTE merchandiser, the software on the Food Driver Board (FDB) **MUST** be Version 1.9 or higher. If the software is less than Version 1.9, you may experience repeated baffle door errors. These errors will disable the Á LA CARTE. Version 1.9 software has been in use since November 2001. If you require new FDB software, please order P/N 360273.

# Components

---

## **Power Supply**

The 120 VAC power cord from the wall outlet enters the machine and plugs into the bottom of the main junction box located on right side of the cabinet. The junction box contains the power distribution components, consisting of the control board, filter, circuit breakers and the transformer. The voltage outputs from the junction box to the board are 24 volts and 8 volts and plugs into the (P3 position) of the Logic Board.

## **High Efficiency Lighting System**

Energy Star ballast & T5 bulb provide increased lighting, exceptional light distribution, and present products in their true, vibrant colors.

## **Main Product Shelves**

There are either five or six main product shelves per machine. Each selection has its own motor mounted to the back of the shelf. Every shelf has its own harness and plug for connecting to the remainder of the circuit through the cabinet receptacle, located in the rear right of the cabinet. The motors are the same on either shelf. It is possible to exchange a five selection shelf with a ten selection shelf or visa versa. You also have the capability to gain one inch either up or down on any shelf. To do this the shelf should be removed and the cabinet back harness receptacle lowered or raised along with the right & left shelf tracks.

## Note

- ◆ When exchanging the shelves, you will not need any parts but you will have to reprogram the machines prices.

## **Pairable Motor Shelf**

The 130 models permit the pairing of two sequential motors on a shelf. This feature allows 2 candy selections to be converted to a dual spiral snack selection, by removing the product divider between the spirals, and pairing the motors electronically. See Mode 23 for additional information on pairing motors.

## **Delivery Bin**

This is located below the display window on the door and is mechanically operated. Should the door become difficult to operate, place a small amount of grease on the arm tracks.

# Components

## Vend Motors

The vend motors used in the 130 Series machines have been specifically developed to operate with the APi Control System. One primary difference that distinguishes the new motors from previous motors is the presence of an eight sided star at the drive hub of the motor. This permits the stopping position of the spiral to be customized by the operator to ensure the best possible delivery of product. Motors are of the fast trac style, with all electronics required to correctly operate the motor contained inside the gear case or the motor housing and no external control board. Each of the motors used with the 130 Control System will have two terminals. The two terminals continue to be used to identify the shelf and column (selection) to be vended.

Each motor requires two wires to operate correctly. These wires are: shelf common, and selection.

Each selection on a shelf will have the same common shelf wire - all shelf harness use wire #12 as a shelf common. This corresponds to the selected shelf wire in the cabinet harness. The terminal for the shelf common in the harness is the smaller of the two.

Selection numbers are assigned from left to right, starting with selection 0. Each selections number corresponds to the number of the wire for that selection.

Selection numbers in the 130 Series Machines support a three digit selection system. The first digit indicates the cabinet number, the second digit is the shelf number and the third digit is the selection number on that shelf.

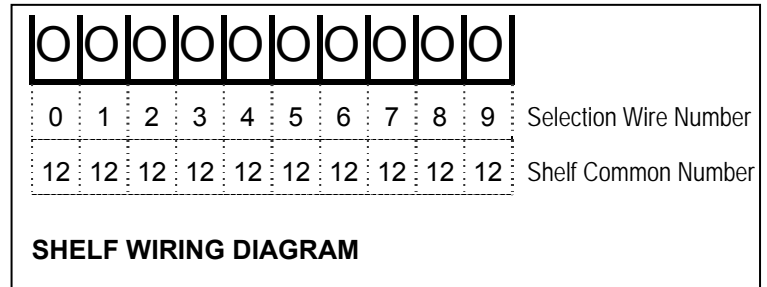

Part #	Case Color code	Description
360275	1/2 blue, 1/2 white, 8 point star drive	CW food/Snack motor
360276	1/2 blue, 1/2 grey, 8 point star drive	CCW Food/Snack motor
360240	All white, 8 point star drive	Dual spiral
360241	1/2 white, 1/2 brown, 8 point star drive	1/2 cycle motor
16700014	1/2 blue, 1/2 brown, square drive	Can motor
360105	All White	Gum & Mint

## 130 Series Motors.

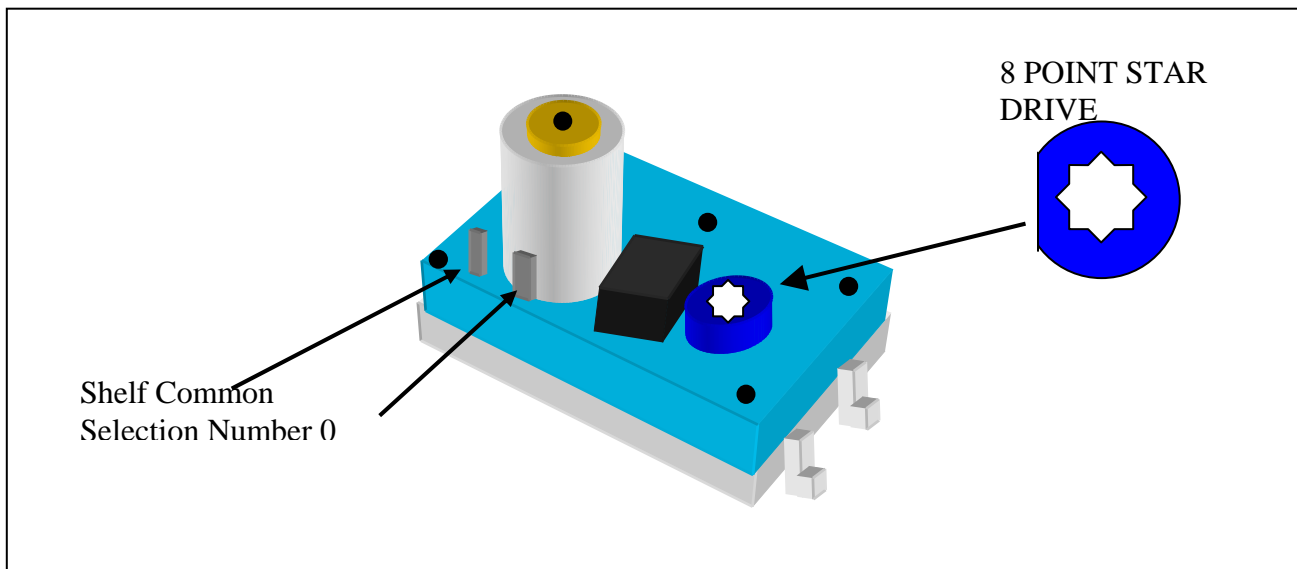

# Components

## Logic Board & Display

The control board contains all of the decision-making and display controls. All peripherals plug into the controller. The all new 130 Series display contains a 2 line, 20 character display capable of pre-programmed graphic messages. All Credit, Price, Diagnostic Information and Options (In Service Mode) will be displayed on this display.

## Keypad

The Selection keypad (shown at right) is located on the swing panel directly below the display. The Selection Keypad is used as an input source for settable data while in the Service Mode. The keypad is only active for service functions when the door is open, so even in the event of vandalism to the control bezel; no access to the control functions is permitted.

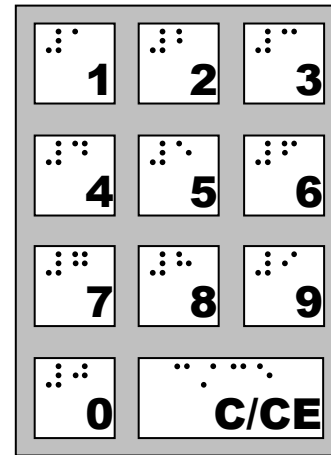

130 Series keypad.

## Fast Track Keypad

The Fast Track Keypad (shown below) is located on the front of the swing out panel directly below the selection keypad. The Fast Track Keypad is only active when the control module door is open, so even in the event of vandalism to the control bezel; no access to the control functions is permitted. The Fast Track Keypad provides you with shortcuts into many of the service modes described elsewhere in this manual.

### Note

- ◆ The “C” key on the Fast Track Keypad is a duplicate of the “C/CE” key on the numeric keypad.

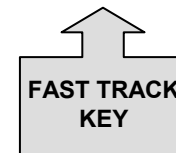

Service Modes in the Programming Section starting on page 5.01 which have Fast Track Keys assigned will have this Fast Track symbol next to them.

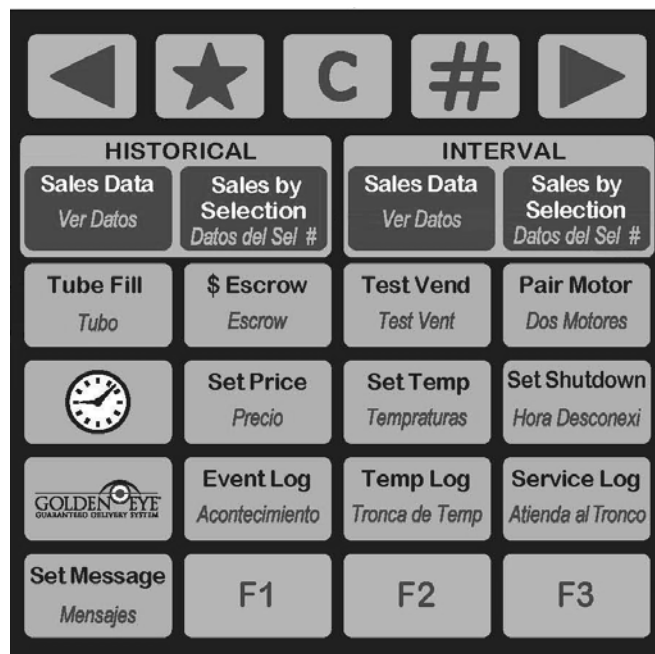

130 Fast Track Keypad.

# Components

---

## Coin Mechs, Validators and Card Readers

The 130 Series Machines support MDB protocol only. The maximum number of MDB payment peripherals is one coin mechanism, one bill validator, and two card reader systems.

The 130 Series will automatically determine at power up which peripherals are connected and configure itself accordingly.

	MDB Coin Mechanism	MDB Bill Validator
<b>Mars</b>	TRC-6510 TRC-6512 VN-4510 CF7512	VN2502-U5M VN2602-U5M
<b>CoinCo</b>	9302-GX, USQ-G701 USQ-G703 USQ-L701	BA32R BA52R MAG32 MAG52
<b>Conlux</b>	USLZ-004-01F CCM 5 G	USLZ-004-01F

◆ **Contact your coin mechanism and validator supplier for additional models.**

## APi Golden Eye® Guaranteed Delivery System

Modes of Operation for the ST/130 Series

### Introduction

The premise behind the development and introduction of Golden Eye (GE) was to improve customer (machine user) satisfaction by guaranteeing delivery of the product they have selected. In addition to increasing customer satisfaction and loyalty, the guaranteed delivery of products reduces operational costs and increases efficiencies, therefore making the operator more profitable.

An average service call costs between \$65 and \$100. Golden Eye reduces these costly calls for product hang-ups and missed vends. Golden Eye also eliminates the time and costs associated with credit vouchers due to missed vends. Lastly, operators may risk losing an account if product vend failure occurs on a repeated basis.

While careful and consistent loading of products helps to ensure a positive vend, Golden Eye provides a positive vend solution that takes these variables out of the equation, and works efficiently and effectively to deliver the product.

### Function

The APi Golden Eye II Guaranteed Delivery System consists of a series of 12 infrared pulsed beams that create a web of interlaced beams just above the opening of the delivery bin in our glassfront snack machines. When any one of these infrared beams is broken by a product falling into the delivery bin during a vend, the GE sensors transmit a signal to the Logic Control Board that the vend occurred successfully, and payment is collected, and change is returned, if required. If the product is not delivered successfully, the credit reappears on the display and allows the customer to choose an alternate item, or press the coin return to receive their money back.

### Modes of operation

The GE II system has four user selectable modes of operation: **Off**, **Home**, **Drop**, or **Drop/Off**. The operator has the option to choose any of these four modes, and once a mode of operation is selected, choose which selections in the machine will be monitored by GE.

#### Off Mode

When GE is set to **Off**, the GE system is disabled, and all selections in the machine will run one time only.

#### Home Mode

When GE is set to **Home**, and the customer makes

their selection, the selection motor begins its cycle, and the GE sensor begins watching for a product to fall into the bin. The selection motor makes a complete revolution, returns to the home position, and pauses for 2 seconds. If no product is detected, **the selection motor then runs a second complete cycle** attempting to deliver the product. The motor pauses a second time, and if no product was detected during this vend, the motor runs a third complete cycle. If a product is delivered during any of the three cycles, the purchase is completed, and any change required is returned. If no product was delivered during any of the three cycles, an error is created (see Golden Eye Errors below). The credit reappears on the display and allows the customer to choose an alternate item, or press the coin return to receive their money back.

#### Drop Mode

When GE is set to **Drop** and the customer makes their selection, the selection motor begins its cycle, while GE sensor begins watching for a product to fall into the bin. The selection motor makes a complete revolution, returns to the home position, and pauses for 2 seconds. If no product is detected, the selection motor begins a second cycle, and if a product interrupts the sensor beams, **the selection motor stops immediately**, leaving the motor in an off home position. If no product is detected during the second cycle, the motor runs a third cycle, and stops immediately upon detection of the product dropping in the bin. If the motor is stopped in an "off home", position, the next time this item is vended, the motor returns to home and pauses. If a product is detected during this partial cycle, the motor remains at home, and the transaction is complete. If no product is detected, the motor begins a second cycle, and if a product falling into the bin is detected, the motor stops immediately, and the transaction is complete. If no product was delivered during any of the three cycles, an error is created (see Golden Eye Errors below). The credit reappears on the display and allows the customer to choose an alternate item, or press the coin return to receive their money back.

#### Drop/Off Mode

The **Drop/Off** mode functions exactly the same as the **Drop** mode, but with the addition of special feature: If there are 3 vends in a row where the machine fails to see a product drop, an error is created, and, **the entire machine is then disabled from vending** until the door is opened, the service mode is entered, and then the door is closed, allowing all motors to be scanned.

The **Drop** mode or the **Drop/Off** mode cannot be used on machines with a can dispenser (Model ST4 & ST5), or with the À LA CARTE food/frozen merchandiser.



# Golden Eye®

## Golden Eye Errors

One of the critical new features of Golden Eye II is an increase in the number and type of diagnostic errors available to the technician to assist them in determining the cause of a GE error. The table below explains each of these available errors. More detailed information on these errors is available in the Troubleshooting section of this manual.

### GOLDENEYE XXX FAILED

After any selection motor (XXX) runs three times without GE detecting a product, an error is posted, and that selection is disabled from vending. If three different selections are disabled with GE errors, then

GOLDENEYE XXX FAILED	Three items missed by the Golden Eye Sensor. XXX indicates which selection.
CABx GOLDENEYE ERROR	Three different selections in a cabinet missed by the Golden Eye Sensor. X indicates which cabinet
CABx TRAN + REC BAD	All Transmitters and Receivers bad - X indicates which cabinet.
CABx RECEIVER Y BAD	Receiver (Sensor) Y failed, Y indicates the number of the Sensor, X indicates which cabinet
CABx TRANSMTR Y BAD	Transmitter (LED) Y failed, Y indicates the number of the LED, X indicates which cabinet
CABx TRN Y TO REC Y	Transmitters Y not seen by Receiver Y, X indicates which cabinet

a GE Disabled error is posted, and GE for the entire machine is disabled, and all selections operate as if GE was set to **Off**. For machines set to **Home**, this disabled condition remains until the machine door is opened and closed. For machines set to **Drop** or **Drop/Off**, the Mode Switch on the control board button must be pressed before closing the door to return disabled selections to operation. The errors will remain until they are cleared.

### Choosing Between Drop vs. Home

Please consider the information below when deciding which mode of Golden Eye to use:

1) If a machine is set to the **Drop** mode, the “automatic motor scan upon door closure to restore all the motors to their home position” is disabled. To perform a motor scan and cycle all motors to their home position, **you must first press the Mode Switch on the Control Board before closing the door**. This trademark feature of APi equipment since 1985 is a valuable diagnostic tool and it will also warn a route service person if they have not pushed all the shelves back into their normal position after servicing.

Utilizing the drop mode disables the automatic function of this important feature. Route service personnel should be instructed to press Mode Switch and the door switch to home all the motors before filling the machine.

2) **If a machine is set to the Drop mode, and a route service person ignores the errors stored, and closes the door without pressing the Mode Switch, they will leave the previously disabled selection still disabled, even though they may have cleared any product jams or misloads, and refilled the selection.**

3) **If a machine is set to the Drop/Off mode, the machine will be disabled if any GE delivery errors are encountered. Special consideration must be given before using this mode of operation.**

3) The **Drop** and **Drop/Off** mode may leave some selections in an “off home” spiral position. Historically, APi snack machine spirals self-home, so it is possible that route service personnel and/or consumers may question a selection’s off home spiral appearance. Consumers may avoid that selection, or the machine altogether, thinking that something is “wrong” with it. This may lead to an unnecessary service call. When using the either of the **Drop** modes you may want to reassure your client that spirals in an “off home” position are normal and will produce a positive vend. If you are using the **Drop/Off** mode, you should be prepared to discuss with your client the reasons behind the decision to disable the entire machine for a product delivery error.

4) The **Home** mode keeps the “motor scan upon door closure to restore all the motors to their home position” automatically enabled.

5) The **Home** mode will always leave selections in their home spiral position.

6) Golden Eye *could* deliver a second product on a failed vend. However, the extra occasional product cost is well worth the savings of a service call due to a product hang-up or missed vend.

## Golden Eye® sensor coverage looking down into the delivery bin.

Front of Machine - Glass

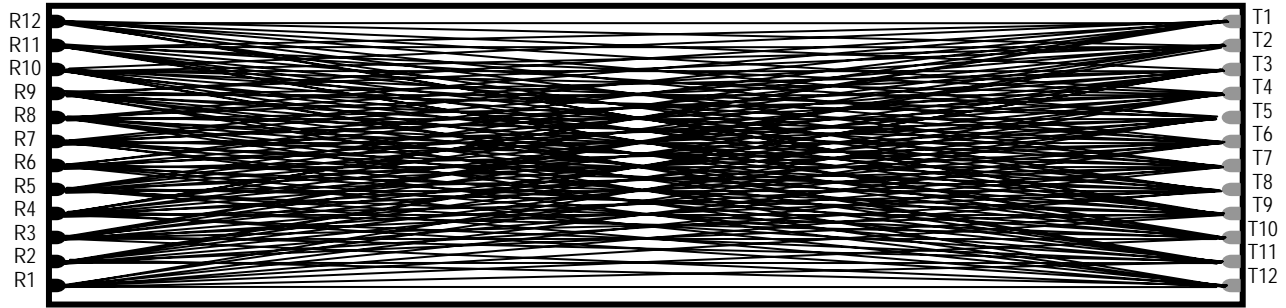

Inside of Machine

ST3/133 Delivery Bin – drawn to scale  
 For scale, circle at left represents a US dime and quarter.

Rxx = Receiver number  
 Txx = Transmitter number

### Connecting Golden Eye from a 320 to a Host Cabinet

When using the Golden Eye Guaranteed Delivery System in a Á LA CARTE – 320 Food/Frozen merchandiser, the Golden Eye harness from the Communications cable must be connected to the existing Golden Eye harness in the host snack machine, or to the Golden Eye junction harness in the 311 Control Module.

1. Identify the harness in the host machine plugged to P11, located on the right edge of the board, bottom connector.
2. In a 130 Series, or ST Studio Series, there should be a connector plugged to the board in P11. When the host machine is a snack, there will be one small 6 pin connector available in this harness. See Photo # 1, below. The mating 6 pin connector from the 320 Communication cable should be connected to this extra 6 pin connector.
3. When using a 311 Tower with one or two Á LA CARTE merchandisers, the harness connected to P11 will have 2 small 6 pin connectors available – see Photo 2 below. In this configuration, the Á LA CARTE identified as Cabinet 1 should be connected to the 6 pin connector with the label on it identifying it a “Golden Eye 1” and Cabinet 2 should be connected to the other 6 pin connector.
4. Access Mode 21 and enable the required selection for Golden Eye.

**NOTE: GOLDEN EYE MUST BE SET TO “HOME” FOR USE IN A 320!**



Photo 1 – Á LA CARTE Golden Eye connection in a host SNACK machine

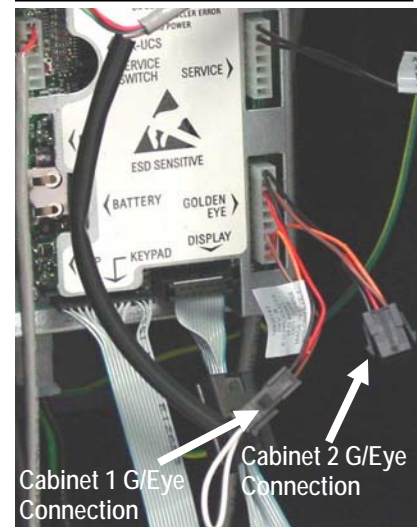

Photo 2 – Á LA CARTE Golden Eye connection in a 311 Tower using Cabinet 1

# Operating System

## Power Up State

Following a power-up or reset condition, the display will scroll "AUTOMATIC PRODUCTS" followed by a flashing "INTERNATIONAL".

## Motor Scan

Upon closing the door the display will show the firmware revision level (see Figure 11), perform a diagnostic routine that will scan and home the motors determining what motors exist in the configuration. After completion of this scan, the status of all the motors will be reported on the display (see Figure 12).

## Standby

In Standby, the operator selected message will appear on both the top and bottom line. The factory default messages are "Have a nice day" on the top line, and "Credit .00" on the second line. See the Operating system, Mode 60 for details on how to change the standby message. As soon as credit is deposited, the accumulated credit will be shown on the bottom line until a selection is made.

## Keypad Echo

When the first numeric key is pressed the display will show the selection number in the third leftmost digit. This character will remain for 5 seconds or until another key is pressed. Once all 3 keys are pressed, the selection will be shown on the display for one second and then the associated price for the product will display. If the selection is disabled or shut down (using the Shutdown pins) the display will show "Invalid selection" for 5 seconds or until a new selection key is pressed. If the selection is enabled but not functioning properly (not present or not home) the display will show "Make Another Selection" for 5 seconds or until a new selection key is pressed.

## Credit Accumulation

Credit may be accumulated through a coin changer, bill acceptor or card reader. Non revaluing card reader credit cannot be mixed with coin and/or bill credit during a single transaction or vend. If card reader revalues the coin & bill credit goes to the card, and then a vend may still be attempted. Credit acceptance will be disabled when the accumulated credit equals or exceeds the highest priced item. Credit accumulation from any source is disabled or escrowed if change is not available. If the amount of card reader credit available exceeds the maximum displayable credit, the maximum credit will be displayed.

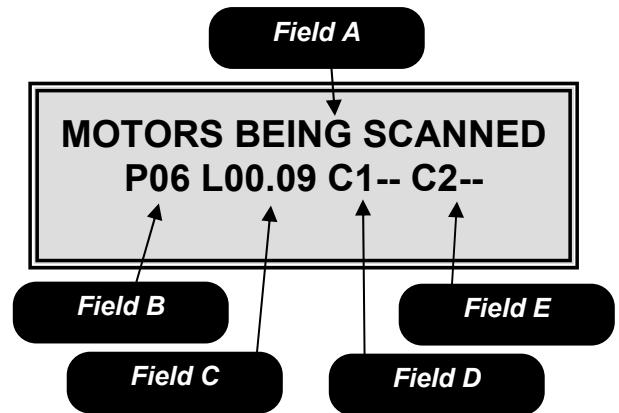

FIGURE 11

**Field A** is the informational heading.

**Field B** is the microprocessor version number.

**Field C** is the software version number.

**Field D** is the software version in the temperature control board for cabinet 1.

**Field E** is the software version in the temperature control board for cabinet 2.

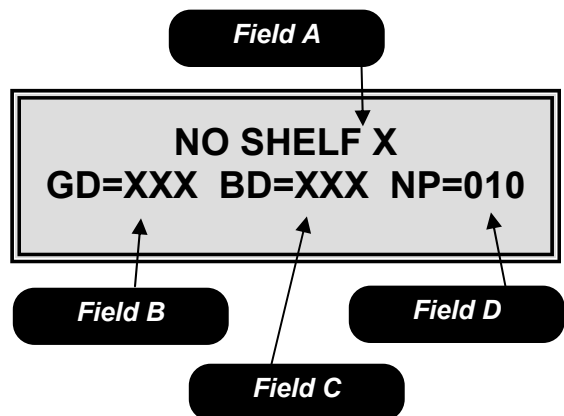

FIGURE 12

**Field A** shows the lowest shelf number not found during the automatic scan of motors.

**Field B** is the number of good motors.

**Field C** is the number of bad motors.

**Field D** is the number of motors not present.

◆ Motor count includes the gum & mint motors.

# Operating System

## Vend Process

After a keypad entry is made the logic board determines if sufficient credit is available for the selection attempted. If the credit is greater than or equal to the selection price, a vend attempt will be made for that selection. During this time, the selection will be shown on the display. If credit is less than the selection price, the correct price and current credit amount will be displayed for 5 seconds or until a new selection key is pressed.

## Change Payment

Change will be returned during the vend process as soon as it is determined that the motor has moved off of the home position. This will change if Golden Eye is active. When Golden Eye is active, the transaction is not completed until the GE sensors confirm delivery of the product. The amount of change to be returned will be displayed until all coinage is paid back. The least amount of coins available will be paid back for all credit returns.

## Use Correct Change

If the level of the changer's least value coin tube is below the lowest sensor, the "Use Correct Change" message will be shown on the display. If the machine is unable to vend the selected item because of low change, the display will show "Use Correct Change" for 5 seconds or until a new selection key is pressed.

## Make Another Selection

If the machine is unable to vend the selected item, the "Make Another Selection " message will be displayed for 5 seconds or until a new selection key is pressed.

## Token Vends

Following the acceptance of a token, the display will show "FREE". Further credit acceptance is disabled and a single item may be selected to vend for the token credit. See the Operating Section Mode 29, for instructions on setting up and choosing which selections will work with tokens.

## Accountability Information

All MIS data is stored as both resettable and non-resettable with the exception of Machine Identification Number, Machine Serial Number, Software Version Number, Number of MIS Resets, Number of Machine Resets and Door Open History, which are stored as non-resettable only. All vend counters will roll over at 7 digits (9,999,999). All cash counters will roll over at 8 digits including the decimal point (999,999.99). Vend accounting (MIS) is updated as shown in Table 1.

Field	Vend Type			
	Token	Vend	Testvend	Freevend
#VENDS	X	X		
\$VENDS (Sale Price)	0	X		
#/PROD	X	X		
\$/PROD (Sale Price)	0	X		
#/TESTVEND			X	
# /FREE				X
\$ /FREE				X
# /TOKEN	X			
\$ /TOKEN	X			

**Table 1: MIS Field Update Chart**

X - Indicates which field is updated for a given vend type.

## Shutdowns

There are 2 options available to shutdown the 130 Series machine.

1. The 130 Series machine is capable of having timed shut down periods. More information can be found in the programming section Mode 51.

2. The control board on the 130 Series machine can be shutdown by creating a closed circuit between pin 3 & pin 4 on the service connector P2. This shutdown type will lock out selections entered into mode 32. When in this shutdown type and a shutdown selection is entered the display will show "Invalid Selection" for 5 seconds or until a new selection key is pressed.



**Caution: Do not apply Voltage to these pins! Damage to the Board will result!**

## DEX/UCS

The 130 Series supports DEX/UCS Communications Protocol - NAMA Vending Industry Data Retrieval Standard. The machine will automatically recognize the DEX/UCS device when it is plugged into the control board and will recognize when the device initiates the communication protocol. The transmission/reception of data to the device will then take place automatically. See the next page of this manual for definitions of the DEX/UCS download protocol.

◆ See Page 5.32 for information regarding the setting of a Serial Number, Machine id and Location id.

# Operating System

The MIS data stored by the machine for a DEX/UCS download is as follows:

DEX/UCS Output	Definition
ID1*API74563219087456123*STXXX*0010*98765432198765432**12345678901234567	Machine S/N*Machine Model*Machine Revision*Location ID**Machine ID #
ID4*2*1*0	# of positions to right of decimal pt*Country (ITCC)*Currency in use
ID5*050510*122708	System Date -YYMMDD*Time - HHMM
ID7***APi	***Manufacturer Code
CB1*API33221144556699887*ST/130*0001	Control Board Serial Number*Model*Software revision
VA1*1200*18*300*5*0*18*0*5	Total Sales Historical Amount*Total Vends Historical Count*Total Interval Sale Amount*Total Interval Vends*Historical Value of All Discounted Paid Vends*Historical count of All Discounted Paid Vends*Interval Value of All Discounted Paid Vends*Interval Count of All Discounted Paid Vends
VA2*0*2*0*0	Historic Value Test Vends*Historic Test Vends*Interval Value Test Vends*Interval Test Vends
VA3*0*0*0*0	Value -Free Vends Historical*Count -Free Vends Historical*Value -Free Vends Interval*Count -Free Vends Interval
TA2*0*0*0*0	Value -Token Vends Historical*Count -Token Vends Historical*Value -Token Vends Interval*Count -Token Vends Interval
CA1*0*0*0	Serial Number*Model*Software revision
CA2*1200*18*300*5	Total Cash Historical*Total Cash Vends Historical*Interval Cash*Interval Vends
CA3*350*0*150*2*1350*0*850*5*200*500	Interval cash received*Interval Cash to Cashbox*Interval Cash to tubes*Interval Value of Bills*Historical Cash received*Historical Cash to Cashbox*Historical Cash to Tubes*Historical Value of Bills*Interval Value of Bills
CA4*50*0*1150*1100	Interval cash dispensed*Interval cash dispensed manually*Historical cash dispensed*Historical cash dispensed manually
CA7*0*0*5*18	Interval Value cash discounts given*Historical Value cash discounts given*Interval Number cash discounts given*Historic Number cash discounts given
CA9*0*0	Value of Vends while in exact change-interval*Value of Vends while in exact change-historical
CA10*0*0	Value of all cash added since last reset*Value of all cash added since initialization
CA15*1225	Value of coin tubes
BA1*29821563422*SPRINTR*504	Bill Validator Serial Number*Model*Software revision
DA1*0*0*0	Cashless 1 Serial Number*Model*Software revision
DA2*0*0*0*0	Cashless 1 Historical Vends*Historical Cash*Interval Vends*Interval Cash
DA4*0*0	Historical Value credited to Cashless 1*Interval Value credited to Cashless 1
PA1*CAN	Can Sales Header
PA2*4294919762*550	Historical Vends-Cans*Historical Cash-Cans
PA1*110*50*110*0 (See Note 1)	Selection ID*Vend price*Product code*Spiral Count
PA2*0*0*0*0 (See Note 1)	Historical Vends Selection 110*Historical Cash Selection 110*Interval Vends Selection 110*Interval Sales Selection 110
PA4*0 (See Note 1)	Historical Free Vends Selection 010
PA5*050510*122708 (See Note 1)	Date & Time of last vend for this selection
EA1*EGS*000000*000008*00	EGS(Door Opening History)*Date YYMMDD*Time HHMM*Duration (minutes)
EA2*EGS*1*4**1	EGS*Interval Door Openings*Historical Door Openings*Current Status 1 = Door open
EA1*EJB*000000*000008*00	EJB (Motor Errors)*Date YYMMDD*Time HHMM*Duration (minutes)
EA2*EJB*60*194**1	EJB*Interval Motor Errors*Historical Motor Errors**Current Status 1 = Motor Error exists
EA1*ELA*000000*000008*00	ELA (Product Delivery Errors)*Date YYMMDD*Time HHMM*Duration (minutes)
EA2*ELA*0*0**0	ELA*Interval Product Delivery Errors*Historical Product Delivery Errors**Current Status 1 = Detector OK
EA1*EJH*000000*000008*00	EJH (Health Code Errors)*DateYYMMDD*Time HHMM**Duration (minutes)
EA2*EJH*0*0	EJH*Interval Health Code Errors*Historical Health Code Errors**Current Status 1 = Detector OK
EA1*OA1E*000000*000008*00	OA1E (Date & Time Resets)*Date YYMMDD*Time HHMM**Duration (minutes)
EA2*OA1E*0*0	OA1E*Interval Date & Time Resets*Historical Date & Time Resets**Current Status Always = 0
EA3*2*****2*2	Number Of Reads With Reset Since Initialization*****Number Of Reads Since Initialization*Number of Resets since Initialization
EA4*000000*000008	(Initialization Timestamp)YYMMDD*Hums
EA5*000000*000008	(Price Setting Timestamp)YYMMDD*Hums
EA7*0*2	Power up/down cycles since last reset*Power up/down cycles since initialization

**Note 1:** PA1, PA2, PA4, PA5 Fields repeat for each valid Selection

**Table 2: DEX/UCS Information.**

# Programming

## Service Modes

The table on the right side of this page is a copy of the decal found on the glass extension inside the 130 machines. This decal provides a list of the service modes described in the following pages.

To access the Service Mode, open the door and press the Service Switch located on the left center of the control board (see Figure 16). If a period of no activity occurs for 5 minutes, the controller will automatically revert to the Operate Mode. Entrance to the Service Mode clears any current credit. If no errors are present the following display will appear (Figure 13).



**FIGURE 13: Initial Service Mode Screen when no errors are present.**

To enter the Service Modes (see Figure 15) press the C key or use the numeric key pad to enter the Service Mode number.

If errors are present the error reporting screen will be displayed (see Figure 14). Use the ◀ and ▶ keys to scroll through the errors listed. Press the # key followed by the \* key to clear the errors. To enter the Service Modes (see Figure 15) press the C key or use the numeric key pad to enter to the Service Mode number.

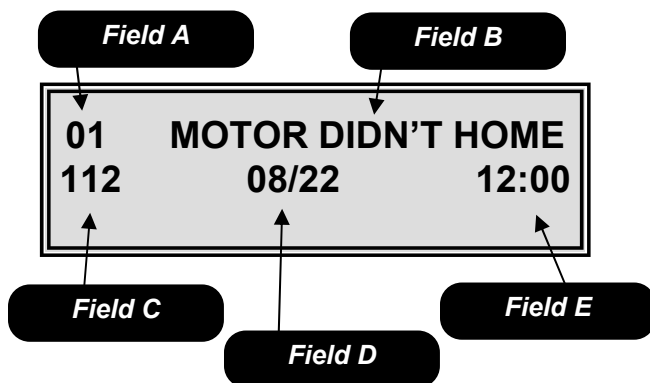

**FIGURE 14: Initial Service Mode Screen when errors are present.**

*Field A* is the sequential number of the error.

*Field B* is the error description field.

*Field C* is the motor number if applicable.

*Field D* is the date of the error.

*Field E* is the time of the error.

◆ See the Troubleshooting Section of this manual for specific information regarding the errors being reported.

LOGIC BOARD FLASH CODES	
LED Status	Meaning
On Steady	Controller is not functioning
Off	Power to LCB is off
1 slow flash	No devices are attached to MDB port, but the controller is working
1 flash	LCB has detected a chiller unit in main cabinet
2 flashes	LCB has detected a second cabinet (A LA CARTE)
3 flashes	LCB has detected an MDB coin mech
4 flashes	LCB has detected an MDB bill validator
5 flashes	LCB has detected an MDB cashless payment system

SERVICE MODES	
ACCOUNTABILITY	
01	Historical Accountability
02	Historical Sales By Selection
03	Interval Accountability
04	Interval Sales By Selection
05	Clear Interval Accountability
06	Print-out Accountability
MACHINE SETUP	
10	Tube Fill Mode
11	External Accountability
20	Price Assignment
21	Golden Eye Enable Setup.
22	Bill Escrow Setup
23	Motor Pairing
24	Winner Vend
25	Force Vend Setup
26	Multiple Vend Setup
27	Combo Vend
28	Free Vend Setup
29	Free Vend Coupon
30	Chip Load/Store
31	Setup Change Payback
32	Machine Lockout
33	Spiral Count
34	Speech / Chime Enable
35	Security
36	Space to Sales
37	Max Payout
REFRIGERATION SETUP	
40	Set Temperature
41	Set up Defrost
42	Health Shutdown By Selection
TIME FUNCTIONS	
50	Current Time
51	Timed Shutdown
52	Timed Discount
53	Timed Messages
MESSAGE SETUP	
60	User Messages
61	After Sale Message
62	Out Of Service Message
DIAGNOSTICS & SERVICE	
80	Test Vend
81	Sequential Event Log
82	Service Log
83	Temperature Log
84	Test Baffle Door

**TO VIEW AND CLEAR ERRORS:**  
 If errors exist, they will be shown on the display upon entering the service mode or by pressing **C** to exit a service mode.  
 Use ▶ or ◀ to scroll through the errors.  
 Press # then \* to clear errors.

**FOR ADDITIONAL INFORMATION ABOUT ANY OF THESE SERVICE MODES, REVIEW THE OPERATING SYSTEM SECTION OF THE SERVICE MANUAL!**

Rev 1.5/23/05 P/N17400152

# Programming

Figure 15 shows the first screen encountered after pressing the C key in either of the previous two screens (Figure 13 and Figure 14). Use the ◀ or ▶ keys to scroll sequentially through the modes or use the numeric key pad to enter the Service Mode number.

Entering one of the Service Mode numbers shown on the following pages allows you to access that Service Mode. **Example: entering 20 will take you into the Price Assignment Mode.**

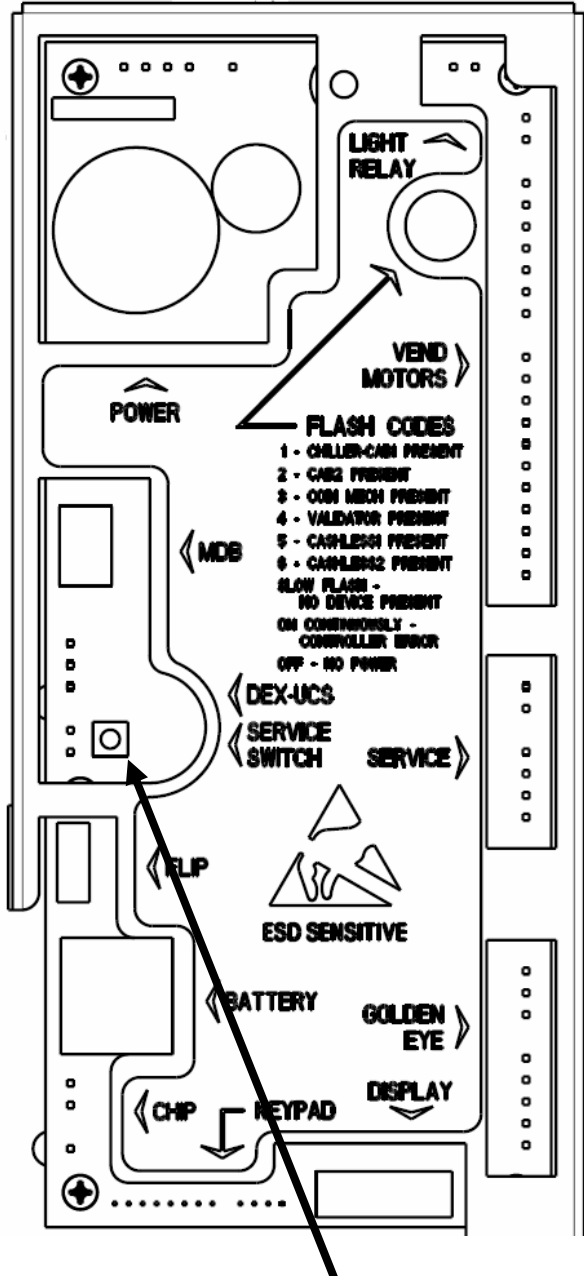

Figure 16: Location of Service Switch.

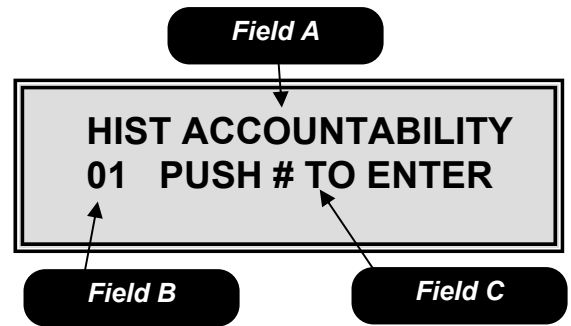

FIGURE 15: First Service Mode Number Screen.

*Field A* is the mode name.  
*Field B* is the mode number.  
*Field C* is the mode entering instructions.  
 Use the ◀ or ▶ keys to scroll sequentially through the mode numbers.

# Programming

## Mode 01 – Historical Accountability

Mode 01 is used to view the historical accountability. To access this mode, press the Service Switch, then use the **Historical Sales Data Fast Track Key** or press **01** on the numeric keypad.

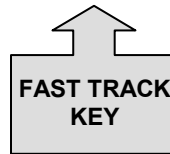

Pressing either the ◀ or ▶ key will sequence you through the historical accountability fields in the order shown in the table below. To exit this mode, press the **C** key or press the Service Switch.

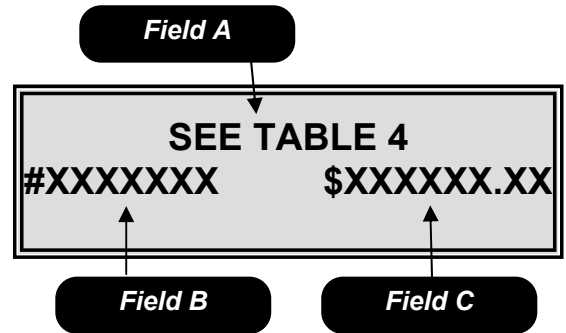

**Mode 01 – Historical Accountability**  
**Field A** is the accountability name field.  
**Field B** is the total vend count field.  
**Field C** is the total value field.

◆ When a data field begins with a # symbol this indicates a vend counter. When the data field begins with a \$ sign this indicates a cash value.

FIELD A The display will show	DESCRIPTION
HIST PAID SALES #0000000 \$0000000.00	Total Value of Sales
HIST NUMBER TESTS #0000000	# of Test Vends
HIST FREE VENDS #0000000 \$0000000.00	Free Vends
HIST CASH VENDS #0000000 \$0000000.00	Cash Sale
HIST VALUE BILLS \$000000	Value of Bills Stacked
HIST VALUE CASH \$0000000.00	Value of Cash In
HIST VALUE TUBE \$0000000.00	Value of Coins to Tubes
HIST VALUE BOX \$0000000.00	Value of Coins Routed to Cash Box
HIST VALUE DISP \$0000000.00	Value of Cash Dispensed
HIST VALUE MDISP \$0000000.00	Value of Cash Manually Dispensed
HIST VALUE ECV \$0000000.00	Value of Exact Change Vends
VALUE TUBE COINS \$0000.00	Current Value of Coins in Tubes
HIST TOKEN VENDS #0000000 \$0000000.00	Token Vends
HIST CASHLESS VENDS #0000000 \$0000000.00	# of Cashless Vends
HIST CAN VENDS #0000000 \$0000000.00	Can Vends
HIST CAB 1 VENDS #0000000 \$0000000.00	Cab 1 Vends
HIST CAB 2 VENDS #0000000 \$0000000.00	Cab 2 Vends
GOLDEN EYE REVISIONS CAB1 00 CAB2 00	Golden Eye Software Revision
HIST NUMBER GE #0000000	# OF Golden Eye Spiral Turns

Table 4: Historical accountability fields.



# Programming

## Mode 02 – Historical by Selection

Mode 02 is used to view the historical accountability by selection. To access this mode, press the Service Switch, then use the **Historical Sales by Selection Fast Track Key** or press **02** on the numeric keypad.

Pressing either the ◀ or ▶ key will sequence you through the selections or use the numeric key pad to enter a selection number into Field A. Field B shows date and Field C shows you the time of the last vend for the selection shown in Field A. Field D shows you the number of vends and Field E shows you the total dollar value of vends for the item in Field A. To exit this mode, press the **C** key or press the Service Switch.

◆ **All time based information is dependent upon the clock on the control board being set correctly, see Mode 50.**

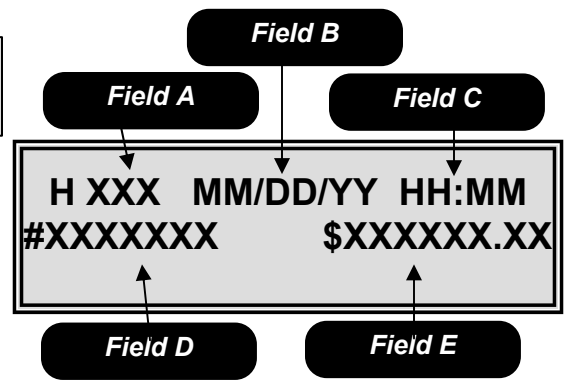
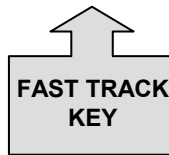

### Mode 02 – Historical by Selection

**Field A** is the item number.

**Field B** is the date of the last vend for the item in Field A.

**Field C** is the time of the last vend for the item in Field A.

**Field D** is the number of vends for the item in Field A

**Field E** is the historical dollar value of all vends for the item in Field A.

## Mode 03 – Interval Accountability

Mode 03 is used to view the interval accountability. To access this mode, press the Service Switch, then use the **Interval Sales Data Fast Track Key** or press **03** on the numeric keypad.

Pressing either the ◀ or ▶ key will sequence you through the interval accountability fields in the order shown in the table below. To exit this mode, press the **C** key or press the Service Switch.

◆ **All interval data is reset to zero under the following two conditions.**

1. A successful DEX download is performed, or
2. Mode 05 is used to clear the Interval data.

**This also applies to the Interval data in Modes 04 and 06.**

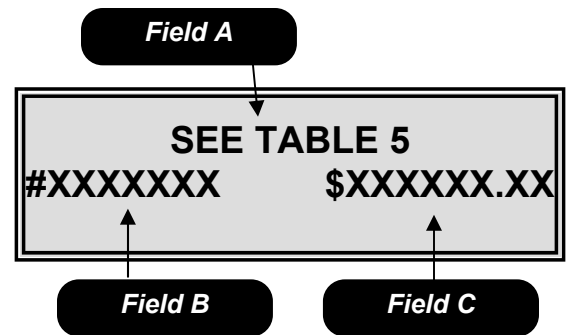
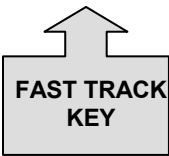

### Mode 03 – Interval Accountability

**Field A** is the accountability name field.

**Field B** is the interval vend count field.

**Field C** is the interval dollar value field.

# Programming

## Mode 04 – Interval by Selection

Mode 04 is used to view the interval accountability by selection. To access this mode, press the Service Switch, then use the **Interval Sales by Selection Fast Track Key** or press **04** on the numeric keypad.

Pressing either the ◀ or ▶ key will sequence you through the selections or use the numeric key pad to enter a selection number into Field A. Field B shows date and Field C shows you the time of the last vend for the selection shown in Field A. Field D shows you the number of vends and Field E shows you the dollar value of vends for the item in Field A. To exit this mode, press the **C** key or press the Service Switch.

◆When the security option in Mode 35 is enabled only Modes 01 through 04 will be accessible without a password. Attempting to access any other Mode will prompt the operator to enter the correct password.

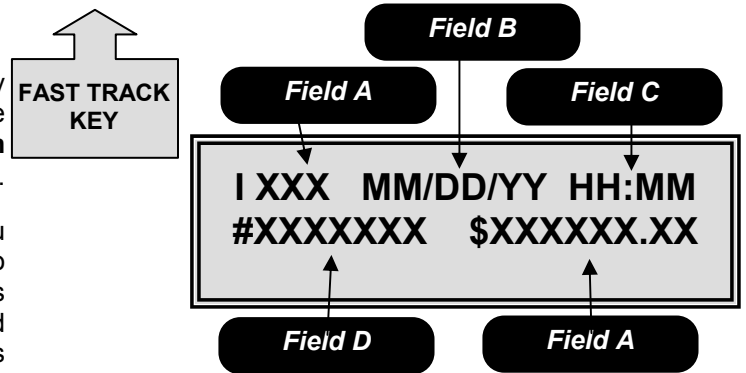

### Mode 04 – Interval by Selection

**Field A** is the item number.

**Field B** is the date of the last vend for the item in Field A.

**Field C** is the time of the last vend for the item in Field A.

**Field D** is the number of vends for the item in Field A

**Field E** is the dollar value of the vend for the item in Field A.

FIELD A The display will show	DESCRIPTION
INTR PAID SALES #0000000 \$0000000.00	Total Value of Sales
INTR NUMBER TESTS #0000000	# of Test Vends
INTR FREE VENDS #0000000 \$0000000.00	Free Vends
INTR CASH VENDS #0000000 \$0000000.00	Cash Sale
INTR VALUE BILLS \$000000	Value of Bills Stacked
INTR VALUE CASH \$0000000.00	Value of Cash In
INTR VALUE TUBE \$0000000.00	Value of Coins to Tubes
INTR VALUE BOX \$0000000.00	Value of Coins Routed to Cash Box
INTR VALUE DISP \$0000000.00	Value of Cash Dispensed
INTR VALUE MDISP \$0000000.00	Value of Cash Manually Dispensed
INTR VALUE ECV \$0000000.00	Value of Exact Change Vends
VALUE TUBE COINS \$0000.00	Current Value of Coins in Tubes
INTR TOKEN VENDS #0000000 \$0000000.00	Token Vends
INTR CASHLESS VENDS #0000000 \$0000000.00	# of Cashless Vends
GOLDEN EYE REVISIONS CAB1 00 CAB2 00	Golden Eye Software Revision
INTR NUMBER GE #0000000	# OF Golden Eye Spiral Turns

Table 5: Interval accountability fields.

# Programming

## Mode 05 – Clear Interval Data

Mode 05 is used to clear the interval data. To access this mode, press the Service Switch, then press **05** on the numeric keypad.

Upon entering the display will show “CLEAR INTERVAL DATA”. Pressing the **#** key followed by the **\*** key will clear all interval data. To exit this mode without clearing the data, press the **C** key or press the Service Switch.

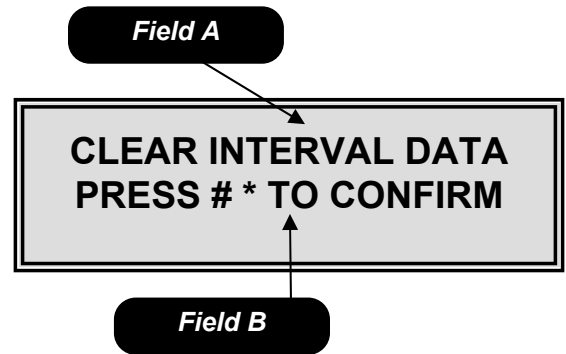

**Mode 05 – Clear Interval Data**  
**Field A** is the mode identification field.  
**Field B** is the instruction field.

## Mode 06 – Print out Accountability

Mode 06 is used to transmit the MIS information to a printer. To access this mode, press the Service Switch, then press **06** on the numeric keypad.

Press the **#** key to send all historical and interval accountability including data by selection. Use the **\*** key to send all historical and interval data but not send the data by selection, for specific details of what is included in each list see Table 6. To exit this mode, press the **C** key or press the Service Switch.

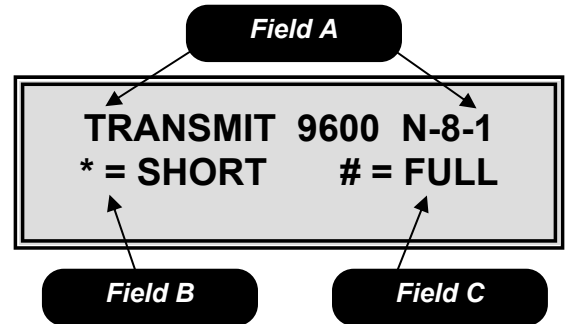

**Mode 06 – Print out Accountability.**  
**Field A** shows the transmission characteristics for the printer.  
**Field B** is the short list download instruction field.  
**Field C** is the full list download instruction field.

### Table 6 Notes

- ◆ An (H) at the end of the definition means historical data.
- ◆ An (I) at the end of the definition means Interval data.
- ◆ The column heading titled F is the full list.
- ◆ The column heading titled S is the short list.
- ◆ Fields highlighted in bold are repeated for each valid selection in the machine.

◆ See Page 5.32 for information regarding the setting of a Serial Number, Machine id and Location id.

# Programming

## Mode 06 - Continued

Field	Definition	F	S
ID101	Machine Serial #	X	X
ID102	Machine ID #	X	X
ID103	Machine Version #	X	X
ID104	Machine Location	X	X
ID106	Machine Asset #	X	X
ID501	System Date	X	X
ID502	System Time	X	X
ID703	Manufacturer Code	X	X
CB101	LCB Serial #	X	X
CB102	LCB ID #	X	X
CB103	LCB Software Version	X	X
ID401	Decimal Point Position	X	X
ID402	Country Code	X	X
ID403	Currency Code	X	X
VA101	Value of all Paid Sales (H)	X	X
VA102	Number of all Sales (H)	X	X
VA103	Value of all Paid Sales (I)	X	X
VA104	Number of all Sales (I)	X	X
VA105	Value of Discounted Sales (H)	X	X
VA106	Number of Discounted Sales (H)	X	X
VA107	Value of Discounted Sales (I)	X	X
VA108	Number of Discounted Sales (I)	X	X
VA201	Value of Test Vends (H)	X	X
VA202	Number of Test Vends (H)	X	X
VA203	Value of Test Vends (I)	X	X
VA204	Number of Test Vends (I)	X	X
VA301	Value of Free Vends (H)	X	X
VA302	Number of Free Vends (H)	X	X
VA303	Value of Free Vends (I)	X	X
VA304	Number of Free Vends (I)	X	X
BA101	Bill Validator Serial Number	X	X
BA102	Bill Validator ID Number	X	X
BA103	Bill Validator Software Version	X	X
CA101	Coin Changer Serial Number	X	X
CA102	Coin Changer ID Number	X	X
CA103	Coin Changer Software Version	X	X
CA201	Value of Cash Sales (H)	X	X
CA202	Number of Cash Sales (H)	X	X
CA203	Value of Cash Sales (I)	X	X
CA204	Number of Cash Sales (I)	X	X
CA308	Value of Bills Stacked (H)	X	X
CA304	Value of Bills Stacked (I)	X	X
CA305	Value of Cash in (H)	X	X
CA301	Value of Cash in (I)	X	X
CA307	Value of Coins to Tubes (H)	X	X
CA303	Value of Coins to Tubes (I)	X	X
CA306	Value of Cash to Cashbox (H)	X	X
CA302	Value of Cash to Cashbox (I)	X	X
CA3010	Value of Bills Stacked (H)	X	X
CA309	Value of Bills Stacked (I)	X	X
CA403	Value of Cash Dispensed (H)	X	X
CA401	Value of Cash Dispensed (I)	X	X
CA404	Value of Cash Manually Dispensed (H)	X	X

Field	Definition	F	S
CA402	Value of Cash Manually Dispensed (I)	X	X
CA702	Value of Cash Dispensed (H)	X	X
CA701	Value of Cash Dispensed (I)	X	X
CA704	Number of Cash Dispensed (H)	X	X
CA703	Number of Cash Dispensed (I)	X	X
CA902	Value of Exact Change Vends (H)	X	X
CA901	Value of Exact Change Vends (I)	X	X
CA1002	Tube Fill Value (H)	X	X
CA1001	Tube Fill Value (I)	X	X
CA1501	Current Value of Coins in Tubes (H)	X	X
MA501	Combo Vend Header	X	X
MA502	Value of Discount for Combo Vends (H)	X	X
MA504	Value of Discount for Combo Vends (I)	X	X
MA503	Number of Combo Vends (H)	X	X
MA505	Number of Combo Vends (I)	X	X
MA502	Value of Winner Vends (H)	X	X
MA504	Value of Winner Vends (I)	X	X
MA503	Number of Winner Vends (H)	X	X
MA505	Number of Winner Vends (I)	X	X
TA202	Number of Token Vends (H)	X	X
TA204	Number of Token Vends (I)	X	X
TA201	Value of Token Vends (H)	X	X
TA203	Value of Token Vends (I)	X	X
DA101	Cashless Serial Number	X	X
DA102	Cashless ID Number	X	X
DA103	Cashless Software Version Number	X	X
DA201	Value of Cashless Vends (H)	X	X
DA203	Value of Cashless Vends (I)	X	X
DA202	Number of Cashless Vends (H)	X	X
DA204	Number of Cashless Vends (I)	X	X
PA101	Can	X	X
PA202	Value of Can Vends (H)	X	X
PA201	Number of Can Vends (H)	X	X
<b>PA103</b>	<b>Selection Number Header</b>	<b>X</b>	<b>X</b>
<b>PA102</b>	<b>Price</b>	<b>X</b>	<b>X</b>
<b>PA107</b>	<b>Selection Status</b>	<b>X</b>	<b>X</b>
<b>PA202</b>	<b>Value of Vends by Selection (H)</b>	<b>X</b>	
<b>PA204</b>	<b>Value of Vends by Selection (I)</b>	<b>X</b>	
<b>PA201</b>	<b>Number of Vends by Selection (H)</b>	<b>X</b>	
<b>PA203</b>	<b>Number of Vends By Selection (I)</b>	<b>X</b>	
<b>PA401</b>	<b>Number of Free Vends by Selection (H)</b>	<b>X</b>	
<b>PA501</b>	<b>Time and Date of Last Vend (H)</b>	<b>X</b>	
<b>PA502</b>	<b>Time and Date of Last Vend (I)</b>	<b>X</b>	
LE101	Loop Trailer	X	X
EA301	Number of Reads with Reset	X	X
EA309	Number of Reads	X	X
EA3010	Number of MIS Resets	X	X
EA401	Date of Initialization	X	X
EA402	Time of Initialization	X	X

\* Items highlighted in bold repeat for each valid selection.

Table 6: MIS Definitions.

# Programming

## Mode 10 – Tube Fill

Mode 10 allows you to fill the coin mech and the logic board will count the money as it goes in and continually track the coin mech inventory. This is the count the board uses when you choose tube leveling as the payout type in Mode 31. To access this mode, press the Service Switch, then use the **Tube Fill Fast Track Key** or press **10** on the numeric keypad.

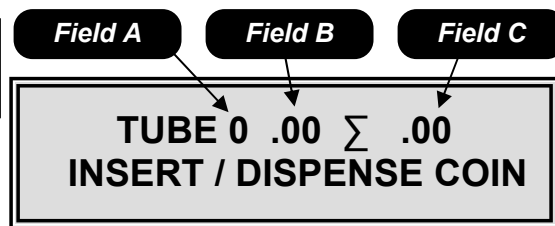
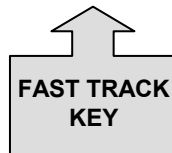

Upon entering the tube fill mode the controller will display the current status of the coin tubes. As coins are inserted into the top of the changer, the display will show the tube the coin was saved to in Field A, the value of all coins in that tube in Field B and the total dollar amount of coins in the changer in Field C. Coins may be dispensed by using the switches on the coin mech. To exit this mode, press the **C** key or press the Service Switch.

### Mode 10 – Tube Fill

**Field A** is the tube number the coin was saved to.

**Field B** is the value of coins in the tube identified in Field A.

**Field C** is the total value of coins in the changer.

◆ **Before using the machine for the first time, the coin mech must have a minimum of \$5 in the coin tubes to permit the acceptance of bills.**

## Mode 11 – External Accountability

Mode 11 is used to permit you or your customer, via a password, to review the total vend count and total cash accepted by the machine. To access this mode, press the Service Switch, then press **11** on the numeric keypad.

Pressing either the ◀ or ▶ key will allow you to toggle back and forth between the fields.

Upon entering the external accountability setup mode, the display will show the current external accountability state. Use the numeric key pad to set a 4 digit security code in field A. Toggle to field B use the # key to turn the external accountability function on (Y) or off (N). To exit this mode, press the **C** key or press the Service Switch.

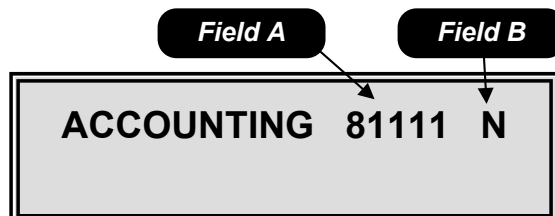

### Mode 11 – External Accountability

**Field A** is the security code field.

**Field B** is the feature on/off field.

### Note

◆ If enabled, instruct the customer/contact to enter 8 and then the 4 digit code. The display will show the total vend count in Field C and the total value in Field D.



### Mode 11 – Customer Viewable Data

**Field C** is the total vend count field.

**Field D** is the total value field.

# Programming

## Mode 20 – Price Assignment

Mode 20 is used to assign the standard price for all selections in the machine. To access this mode, press the Service Switch, then use the **Set Price Fast Track Key** or press **20** on the numeric keypad.

Pressing either the ◀ or ▶ key will allow you to toggle back and forth between the fields. Use the numeric keypad to enter the price in Field A, then toggle to Field B to assign the current price to a selection. To exit this mode, press the **C** key or press the Service Switch.

### Note

- ◆ The maximum price allowed is \$99.99.

### Special Actions

- ◆ Setting selections with a blank price disables that selection which means DEX information will no longer be transferred or displayed for items disabled in this way. The blank price is set by depressing the # Key.
- ◆ The \* key can be used as a wildcard in Field B to set entire rows (12\*) or the entire machine (1\*\*).
- ◆ After assigning the prices, make sure you adjust the scrolling price tabs to reflect the current or new price.

◆ You can use the ◀ or ▶ key while in the operate mode with the door open to check the prices in the machine.

## Mode 21 – Golden Eye Enable Setup

Mode 21 is used to set up the Golden Eye Guarantee Delivery System. To access this mode, press the Service Switch, then use the **Golden Eye Fast Track Key** or press **21** on the numeric keypad.

Upon entering the Golden Eye setup mode, the display will show the current Golden Eye state in Field A. Toggle between the available options in Field A by using the # key. Each selection affected by the setting in Field A are shown in sequence in Field B, use the ◀ or ▶ key to scroll through these selections. Use the numeric keypad to add selections in Field B. To remove a selection from Field B, press the # key while the selection number is displayed. To exit this mode, press the **C** key or press the Service Switch.

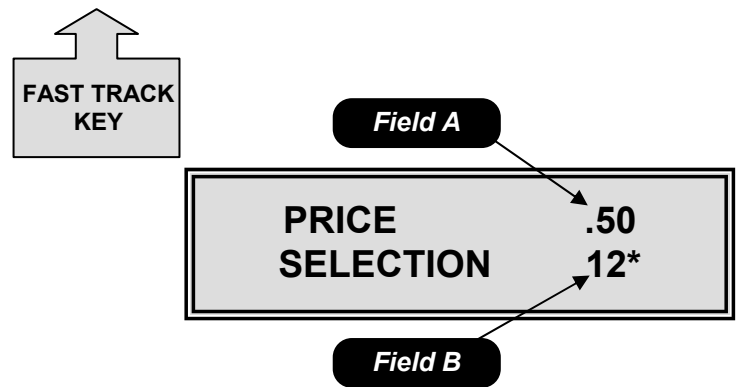

### **Mode 20 – Price Assignment**

**Field A** is the price setting field.

**Field B** is the selection assignment field.

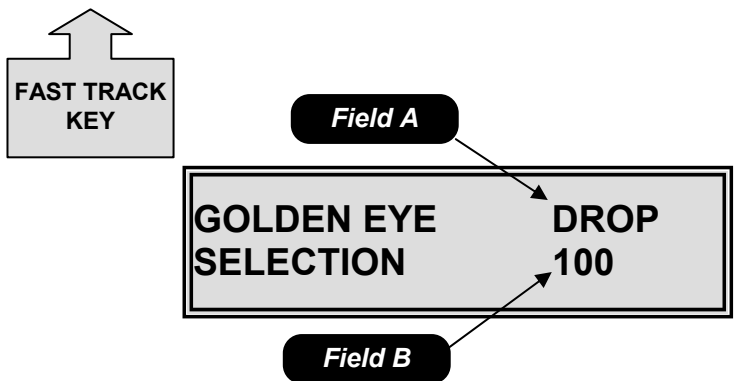

### **Mode 21 – Golden Eye Enable Setup**

**Field A** is the Golden Eye option setting field.

**Field B** is the selection assignment field.

# Programming

---

## Mode 21 - Continued

### Available Options

**Drop** – The motor will stop as soon as the product is detected after the first complete revolution.

**Drop/off** – Motor will stop as soon as the product is detected after the first revolution, but if there are 3 vends in a row where the machine fails to see a product drop, the machine stops vending until the service mode is entered.

**Home** – The motor will home before stopping.

**Off** – Golden Eye is disabled, the motor will stop as soon as it reaches home whether a product has been delivered or not.

◆ The Drop mode or the Drop/Off mode cannot be used on the À LA CARTE food/frozen merchandiser (Model 320).

See page 3.05 for a complete description of the function of the Golden Eye Guaranteed Delivery System.

### Special Actions

- ◆ The \* key may be used as a wildcard to set the entire rows (12\*) or the entire machine (1\*\*).
- ◆ To delete all selections press the # key then the \* key in sequence.

◆ To home motors left off home in the DROP or DROP/OFF mode, open the door and press the mode switch, then close the door.

## Mode 22 – Bill Escrow Setup

Mode 22 is used to set the bill escrow option. To access this mode, press the Service Switch, then use the \$ **Escrow Fast Track Key** or press 22 on the numeric keypad.

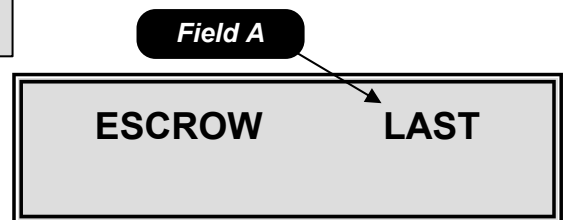
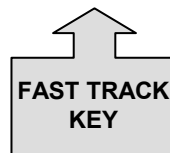

Upon entering the bill escrow set up mode, the display will show the current bill escrow state in Field A. Use the # key to toggle between the available options in Field A. To exit this mode, press the C key or press the Service Switch.

**Mode 22 – Bill Escrow Setup**  
*Field A* is the escrow setting field.

### Available options

**First** – The machine will hold the first bill deposited in escrow until a vend is initiated. Once a vend is initiated the bill must be stacked before the product will be dispensed. In this mode only one bill will be accepted. If the coin return is depressed, the bill will be returned to the customer.

**Last** – The machine will accept bills to the highest vend price. If the coin return is depressed the last bill inserted will be returned and all previous bills inserted will be returned in change.

**Off** – All bills accepted will be stacked immediately. If the coin return is depressed, change will be paid back.

# Programming

## Mode 23 – Motor Pairing

Mode 23 is used to pair an even numbered motor with the next sequential odd numbered motor. To access this mode, press the Service Switch, then use the **Pair Motor Fast Track Key** or press **23** on the numeric keypad.

Upon entering the motor pairing set up mode, the display will show “100 PAIRED TO”. Use the numeric key pad to enter the even numbered motor to be paired in Field A. The odd numbered motor next in sequence will automatically appear in Field B. Use the ◀ or ▶ keys to scroll through the list of paired motors. Use the # key to remove a previously paired combo. To exit this mode, press the **C** key or press the Service Switch.

### Notes

- ◆ Only motors in the same row of a machine may be paired.
- ◆ All pricing, discounting and vending options are set using the selection number of the left motor in the pair.
- ◆ Any even number motor may be paired to the next odd numbered motor in sequence. (e.g. 110 will always be paired with 111, 112 with 113, etc)

## Mode 24 – Winner Mode

Mode 24 is used to set the frequency that free items will be awarded during cash vends only. To access this mode, press the Service Switch, then press **24** on the numeric key pad.

Pressing either the ◀ or ▶ key will allow you to toggle back and forth between the fields.

Upon entering the Winner Mode, the display will show the current winner setting in Field A. Use the numeric key pad to enter the number of vends between winners up to 9999, then toggle to Field B, use the # key to turn the Winner Mode on (Y) or off (N). To exit this mode, press the **C** key or press the Service Switch.

When a customer wins, the credit will be returned the beeper will sound 5 times and the display will show “**WE HAVE A WINNER!!**”.

### Notes

- ◆ Vends made while on free vend, test vend or the second vend of a combo vend are not counted for the purpose of determining the winner.
- ◆ Setting the number to 0000 will result in every vend being a winner.

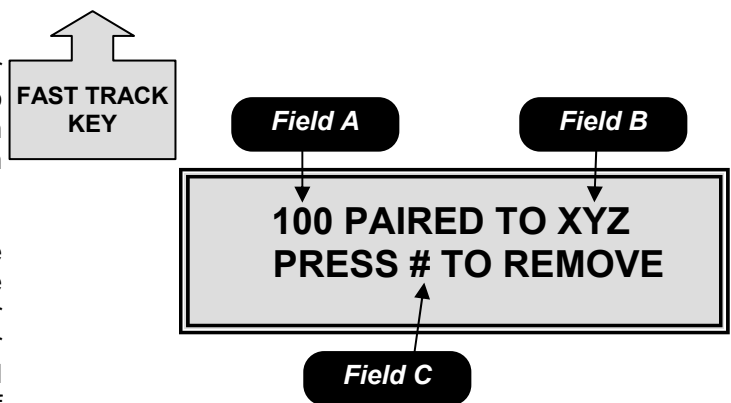

### Mode 23 – Motor Pairing

**Field A** is the even motor number to be paired.

**Field B** is the odd number motor to be paired this number will automatically appear once a selection is entered in field A.

**Field C** is the instructions to remove a previously set motor pair.

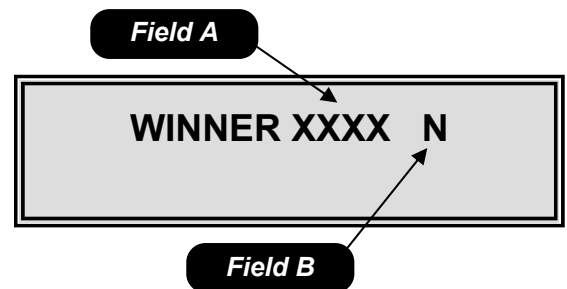

### Mode 24 – Winner Mode

**Field A** is the number of vends between winners.

**Field B** is the winner on/off field.



# Programming

## Mode 25 – Force Vend Setup

Mode 25 is used to set the force vend option. To access this mode, press the Service Switch, then press **25** on the numeric keypad.

Upon entering the force vend mode, the display will show the current force vend state. Use the **#** key to toggle between on and off in Field A. To exit this mode, press the **C** key or press the Service Switch.

### Available options

**On** – The customer must purchase an item before any credit will be returned.

**Off** – The customer may receive their money back at any time.

### Notes

- ◆ Force vend does not apply to the use of debit cards or to bills held in escrow, only to non-tube coins.

## Mode 26 – Multi-vend Setup

Mode 26 is used to set the multi-vend option. Multi-vend allows the customer to make an additional selection using the change amount due from the prior vend. To access this mode, press the Service Switch, then press **26** on the numeric keypad.

Pressing either the **◀** or **▶** key will allow you to toggle back and forth between the fields.

Upon entering the multi-vend mode the display will show the current multi-vend state. Use the **#** key to toggle between on and off, then toggle to Field B to change the time-out setting, the default setting is 30 seconds if a larger time-out setting is desired use the numeric key pad to enter the larger time. To exit this mode, press the **C** key or press the Service Switch.

### Available options

**On** – Allows customer to make additional selections as long as sufficient credit exists to purchase the lowest priced item in the machine. The customer may establish additional credit at any time when in this mode. If the customer presses the coin return lever, or the amount of available credit drops below the lowest price in the machine or the time-out expires, change is returned regardless of the state of multi-vend.

**Off** – Change will be returned immediately after the sale.

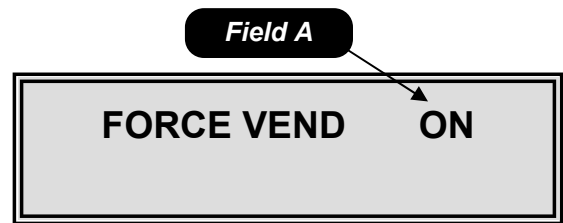

**Mode 25 – Force Vend Setup**  
**Field A** is the force vend on/off field.

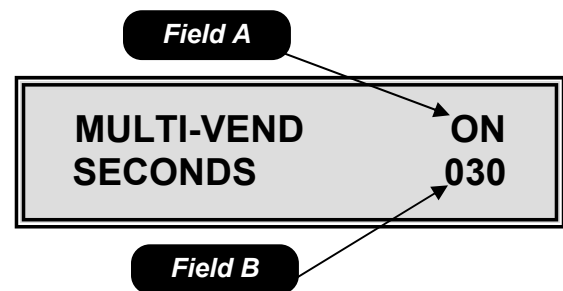

**Mode 26 – Multi-vend Setup**  
**Field A** is the multi-vend on/off field.  
**Field B** is the time-out field; the default time is 30 seconds. The available range is 5 to 90 seconds.

# Programming

## Mode 27 – Combo Vend Setup

Mode 27 is used to set the combo vend feature. A combo vend allows you to set up a selection to be offered in conjunction with another selection. To access this mode, press the Service Switch, then press **27** on the numeric keypad.

Pressing either the ◀ or ▶ key will allow you to toggle back and forth between the fields.

Upon entering the combo vend mode the display will show the current combo vend state. Use the # key to toggle between on (Y) and off (N) in Field A, then toggle to Field B use the numeric key pad to set the time out value in seconds. The time-out value is the number of seconds the customer has to add additional credit in order to purchase a combo vend combination. Then toggle to Field C use the # key to set a unique number for the combination, this number is settable from 0 to 9 allowing for 10 different combinations at any 1 time. Then toggle to Field D and use the numeric key pad to set the item that is to be selected by the customer, then toggle to Field E and use the numeric key pad to select the item to be offered in combination with the customer selected item. Then toggle to Field F and use the numeric key pad to set the discount amount of the combination item. Then toggle to Field G and use the # key turn the selected combination vend on (Y) or off (N). To exit this mode, press the **C** key or press the Service Switch.

### Notes

- ◆ Setting the discount amount in Field F to \$99.99 will allow the discounted item to be vended for free.
- ◆ Wild carding with the \* key is not allowed in the combo vend.
- ◆ When combo vend is active, the display will scroll the message “FEATURED ITEM \*\*\* BUY XXX AND SAVE \$ ON YYY”.

## Mode 28 – Free Vend Option

Mode 28 is used to set the free vend option. To access this mode, press the Service Switch, then press **28** on the numeric keypad.

Upon entering the free vend option mode the display will show the current free vend state. Use the # key to toggle the free vend on or off in Field A. To exit this mode, press the **C** key or press the Service Switch.

### Note

- ◆ Free vend applies to the entire machine.

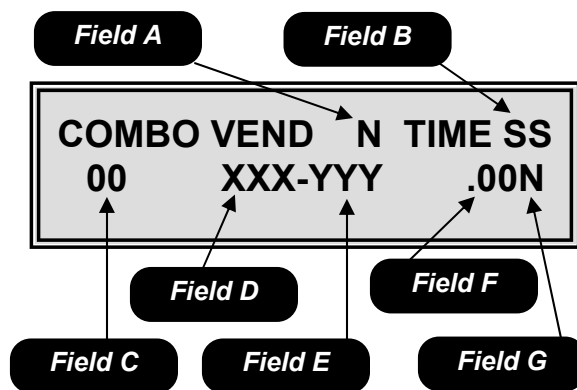

### Mode 27 – Combo Vend Setup

**Field A** is the global combo vend on/off field.

**Field B** is the time-out field measured in seconds.

**Field C** is the number assigned to the combo vend.

**Field D** is the item selected by the customer.

**Field E** is the item to be vended in combination with the customer selected item.

**Field F** is the discount amount of the combination item.

**Field G** allows the user to turn the combination item on or off. But leave the rest of the combination vends in use.

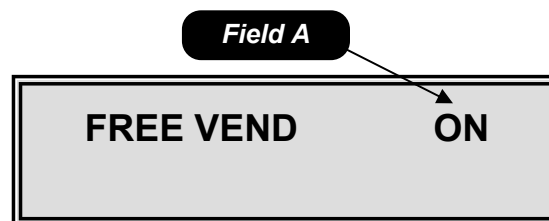

### Mode 28 – Free Vend Option

**Field A** is the free vend option on/off field.

# Programming

## Mode 29 – Free Vend Coupon

Mode 29 is used to set the free vend coupon or token option. To access this mode, press the Service Switch, then press **29** on the numeric keypad.

Upon entering the free vend coupon mode the display will show Free Vend Coupon XXX in Field A, where XXX is the selection enabled for the free vend coupon. Each selection enabled for the free vend coupon is shown in sequence in Field A by depressing the ◀ or ▶ key. Use the numeric key pad to add selections. To remove a selection, press the # key while the selection number is displayed. To exit this mode, press the **C** key or press the Service Switch.

### Special Actions

- ◆ The \* key may be used as a wildcard to set entire rows (12\*) or the entire machine (1\*\*).

## Mode 30 – Chip Retrieve/Store Mode

Mode 30 is used to retrieve or store information from the touch memory button (*CHIP*). To access this mode, press the Service Switch, then press **30** on the numeric keypad.

To store all programmable information to *CHIP* press the \* key as shown in Field B. To upload information previously stored on a *CHIP* press the # key as shown in field C. To exit this mode, press the **C** key or press the Service Switch.

- ◆ **To make sure that the information being transferred from the *CHIP* is compatible the software revision numbers will be compared before the transfer. If the version on the *CHIP* is not compatible the transfer is canceled and the display will show “CHIP NOT COMPATIBLE”.**

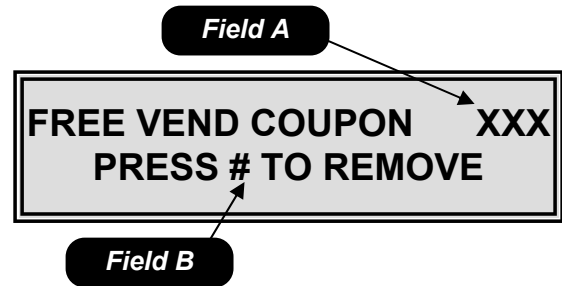

### **Mode 29 – Free Vend Coupon**

**Field A** is the selection enabled field.  
**Field B** is the selection remove field.

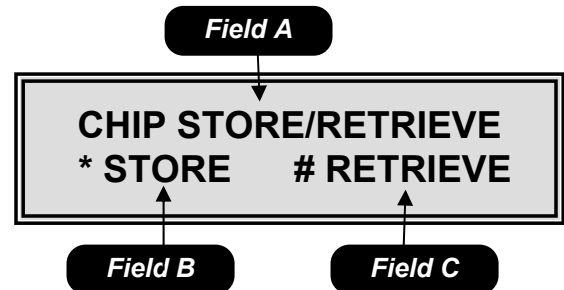

### **Mode 30 – Chip Retrieve/Store Mode**

**Field A** is the name of the mode.  
**Field B** is the download to *CHIP* function.  
**Field C** is the upload from *CHIP* function.

# Programming

## Mode 31 – Change Payback Type

Mode 31 is used to set the change payback option. To access this mode, press the Service Switch, then press **31** on the numeric keypad.

Upon entering the change payback mode, the display will show the current change payback state in Field A. Use the **#** key to toggle through the available options. To exit this mode, press the **C** key or press the Service Switch.

### Available options

**LEAST** – The least amount of coins will be paid back.

**LVL3** – The coin changer makes the payback decision based on how much money it thinks is in each tube. You should use the “Tube Fill” menu item (Mode 10) when you use this option.

## Mode 32 – Selection Lockout

Mode 32 is used to lock selections from use in conjunction with an external switch. To access this mode, press the Service Switch, then press **32** on the numeric keypad.

Upon entering the lockout mode the display will show LOCK SELECTION XXX in Field A. Where XXX is the selection enabled for lock out. Use the ◀ or ▶ key to scroll through each selection affected by the lockout. Use the numeric key pad to add selections. Use the **#** key while the selection number is displayed to remove selections. To exit this mode, press the **C** key or press the Service Switch.

### Special actions

- ◆ The \* key may be used as a wildcard.
- ◆ If all selections are disabled the lights will turn off and no money will be accepted.

### Note

- ◆ The mechanical lockout of selections is done by adding an external key switch or other switch across pins P2-3 & P2-4 on the logic board.
- ◆ The machine will not function properly in shutdown when the door is open. The machine must **not** have the shut down switch active while the door is open.

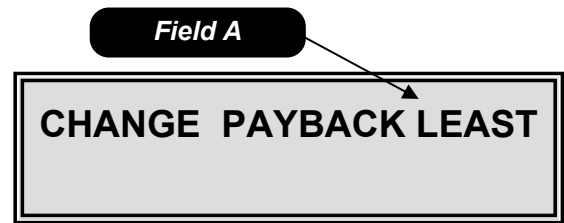
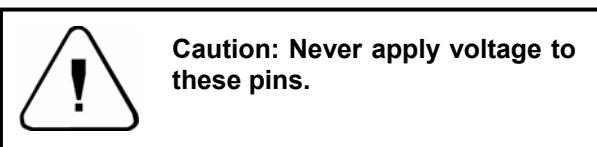

**Mode 31 – Change Payback Type**  
*Field A* is the payback option selection field.

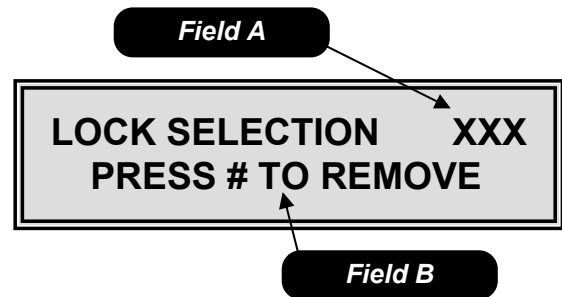

**Mode 32 – Selection Lockout**  
*Field A* is the selection disable field.  
*Field B* is the selection remove field.

# Programming

## Mode 33 – Set Spiral Count

Mode 33 is used to set the spiral count. Spiral count allows you to program the number of spaces in each spiral. When a selection has vended all product out of the individual spiral, the display will show 'SOLD OUT'. To access this mode, press the Service Switch, then press **33** on the numeric keypad.

Pressing either the ◀ or ▶ key will allow you to toggle back and forth between the fields.

Upon entering the set spiral count mode the controller will display SPIRAL CNT OFF/ON in Field A. Use the # key to toggle between OFF/ON. If Field A is set to off no further action is needed.

If Field A is set to on, toggle to Field B now use the numeric key pad to enter the selection number to be set. Toggle to Field C and use the numeric key pad to enter the number of spaces for the selection number displayed in Field B. Repeat the above steps for each selection. To exit this mode, press the **C** key or press the Service Switch.

When spiral count is on (Field A), each time the main cabinet door is opened, the display will prompt "STOCK MACHINE -N". Use the # key to toggle between yes (Y) and no (N). If Y is selected the machine will assume that all spirals have been filled and the machine is fully stocked. If N is selected, then the sold out status of each spiral remains.

### Special actions

- ◆ The \* key can be used as a wildcard in Field B to set entire rows (12\*) or the entire machine (1\*\*).
- ◆ To disable a selection from spiral count set Field C to 0.

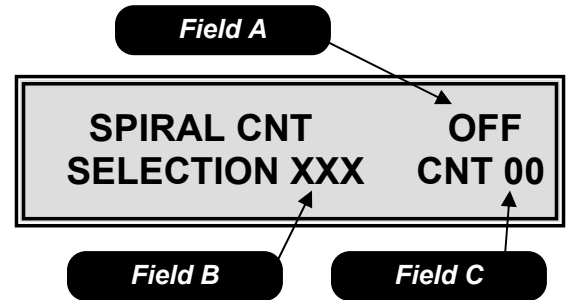

### **Mode 33 – Set Spiral Count**

**Field A** is the spiral count on/off field.

**Field B** is the item selection field.

**Field C** is the spiral count field.

# Programming

## Mode 34 – Speech / Chime

Mode 34 is used to set the Speech/Chime options. To access this mode, press the Service Switch, then press **34** on the numeric keypad.

Pressing either the ◀ or ▶ key will allow you to toggle back and forth between the fields.

Upon entering the speech/chime options mode, the controller will display the current SPEECH setting in field A and the current CHIME setting in Field B. The # key is used to toggle between on and off for each field. To exit this mode, press the C key or press the Service Switch.

### Notes

- ◆ Turning the chime off will disable the beep from sounding in all conditions, except for the health code warning set in Mode 42.
- ◆ When Speech is on, all messages in the service mode will be transmitted via the DEX port for use with an audio interface.
- ◆ When Speech is on, the DEX/UCS port can no longer be used for any other communication.

## Mode 35 – Security

Mode 35 is used to set the Security options. To access this mode, press the Service Switch, then press **35** on the numeric keypad.

Pressing either the ◀ or ▶ key will allow you to toggle back and forth between the fields.

Upon entering the security mode, the current security settings will be displayed. Use the numeric key pad to set the desired security code in Field A, then toggle to Field B, use the # key to toggle between on (Y) and off (N). To exit this mode, press the C key or press the Service Switch.

With the security code, the service person will only be allowed access to Modes 01 to 04. Trying to enter any other modes will change the display to “ENTER SECURITY CODE”. Once the proper code has been entered all modes in the machine will be accessible until the service mode is exited.

### Note

- ◆ Factory default settings are off (N) and a security code of 1111.
- ◆ **Once the service mode as been exited, the code must be re-entered to access Modes 05 through 84.**

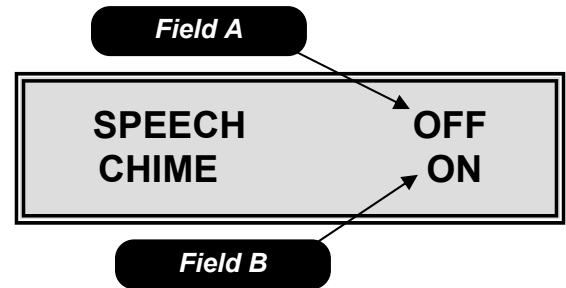

**Mode 34 – Speech/Chime**  
*Field A* is the speech option field.  
*Field B* is the chime option field.

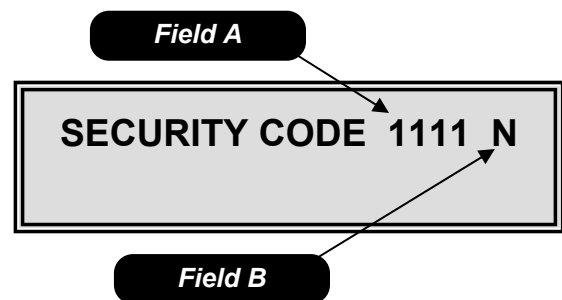

**Mode 35 - Security**  
*Field A* is the security code entry field.  
*Field B* is the security on/off field.

# Programming

## Mode 36 – Space to Sales

Mode 36 is used to set two columns to run together in a Space to Sales manner. To access this mode, press the Service Switch, then press **36** on the numeric keypad.

Pressing either the ◀ or ▶ key will allow you to toggle back and forth between the fields.

Upon entering the Space to Sales mode, the display will show the current Space to Sales settings. Use the # key in Field A to turn the Space to Sales feature on (Y) or off (N). Toggle to Field B and use the # key to set a unique number for the space to sales combination. This number is settable from 0 to 9 allowing for 10 different Space to Sales combinations at any one time. Toggle to Field C and use the numeric keypad to set the first item number to be vended in a space to sales manner, then toggle to Field D and use the numeric keypad to set the second item number to be vended in a space to sales manner. Toggle to Field E, and use the # key to turn the selection numbers set in Field B to on (Y) or off (N). To exit this mode, press the **C** key or press the Service Switch.

◆ **Space to sales allows you to program two selection spirals to operate as one in an alternating method. For example if selection 110 is entered into Field C and selection 112 is entered into Field D, every time selections 110 or 112 are selected the product will be vended from spiral 110 one time and 112 the next time. It is important that any selections enabled in this mode contain the same product. The goal of space to sales is to increase the capacity of an individual item while preventing the inevitable empty spiral from occurring on a fast moving product.**

## Mode 37 – Set Max Payout Mode

Mode 37 is used to set the Maximum Payout options. To access this mode, press the Service Switch, then press **37** on the numeric keypad.

Pressing either the ◀ or ▶ key will allow you to toggle back and forth between the fields.

Upon entering the maximum payout mode, the controller will display the current max payout setting.

Toggle to Field A use the numeric keypad to set the maximum value of coins to be returned, then toggle to Field B and use the # key to turn on (Y) or off (N) the option. To exit this mode, press the **C** key or press the Service Switch.

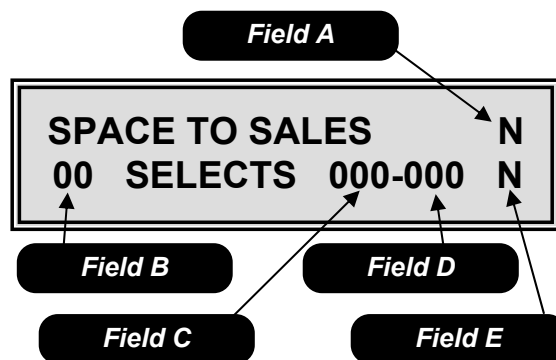

### **Mode 36 – Space to Sales**

**Field A** is the space to sales on/off field.

**Field B** is the product type number field.

**Field C** is the first selection setting field.

**Field D** is the second selection setting field.

**Field E** is the product type on/off field

◆ **Caution – Space to Sales items must be priced identically.**

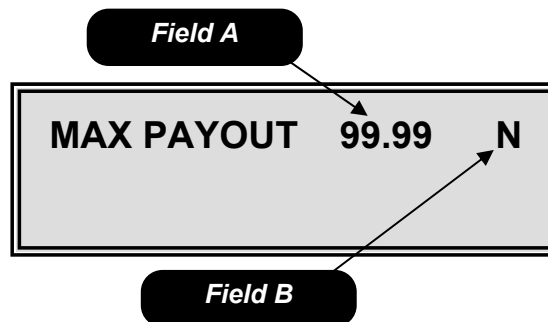

### **Mode 37 – Set Max Payout**

**Field A** is the maximum coin payout field.

**Field B** is the maximum coin payout on/off field.

# Programming

## Mode 37 – Continued

### Note

- ◆ When turned on (Y), if the credit after the sale is greater than the Max Payout set point in Field A, the machine will go into an automatic multi-vend (mode 26).

## Mode 40 – Set Temperature

Mode 40 is used to set the Temperature of the cabinet(s). To access this mode, press the Service Switch, then use the **Set Temp Fast Track Key** or press **40** on the numeric keypad.

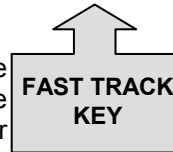

Pressing either the ◀ or ▶ key will allow you to toggle back and forth between the fields.

Upon entering mode 40, the display will show the current temperature range setting. Field A is the cabinet selection field, use the # key to choose between 1 (cabinet 1) or 2 (cabinet 2). Then toggle to Field B to choose the temperature range option, see below for the available options. Then toggle to Field C to set the temperature for the can cube or a single zone machine, use the 1 key to raise, or the 2 key to lower the temperature. If applicable, toggle to Field D to set the temperature for the upper half of a dual zone machine. Then toggle to Field E; use the # key to choose between Fahrenheit (F) and Celsius (C) temperature scales. To exit this mode, press the C key or press the Service Switch.

### Field B Temperature Range Options

**AMBIENT** – No temperature control. Field C will show ----- F.

**ZONE** – The target temperature in Field C for each zone in the machine is settable from +40° to +70° F (4° to 21°C). This setting is only available if Field A is set to cabinet 1.

**FOOD** – The target temperature in Field C is fixed at +36° F (2°C).

**FROZEN** – The target temperature in Field C is settable from -15° to +10° F (-12° to -26°C).

- ◆ The temperature is adjustable when Field B is set to **CHILLED** or **FROZEN** only.

- ◆ All temperature ranges have a + or – range of 3°F (2°C).

- ◆ The temperature inside the machine can be viewed from the outside by pressing and holding the 0 key for °F or C/CE key for °C.

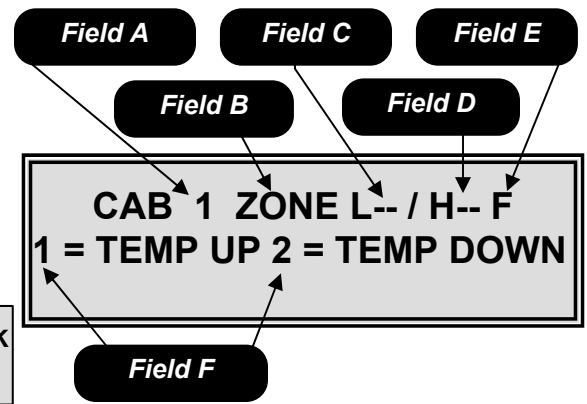

### Mode 40 – Set Temperature for Cabinet 1

**Field A** is the cabinet selection field.

**Field B** is the temperature range selection field.

**Field C** is the temperature setting field for the can cube or the setting for a single zone machine.

**Field D** is only used on a dual zone machine, and is the temperature setting for the top half of the machine.

**Field E** is the temperature scale field, F for Fahrenheit or C for Celsius.

**Field F** is the temperature raising and lowering instruction field.

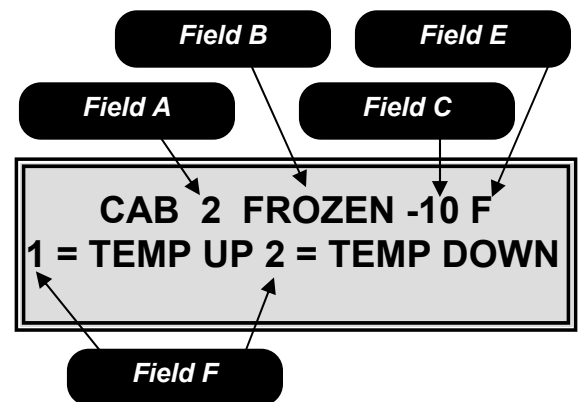

### Mode 40 – Set Temperature for Cabinet 2

**Field A** is the cabinet selection field.

**Field B** is the temperature range selection field.

**Field C** is the temperature setting field. The default setting for frozen is -10°F.

**Field D** is the temperature scale field, F for Fahrenheit or C for Celsius.

**Field E** is the temperature raising and lowering instruction field.

- ◆ The recommended temperature setting for a chilled snack is 65°F.



When a new 130 Series machine is used to host a Model 320 Á LA CARTE merchandiser, the software on the Food Driver Board (FDB) MUST be Version 1.9 or higher. If the software is less than Version 1.9, you may experience repeated baffle door errors. These errors will disable the Á LA CARTE. Version 1.9 software has been in use since November 2001. If you require new FDB software, please order P/N 360273.



# Programming

## Mode 41 – Defrost

Mode 41 is used to set the Defrost schedule and to start a Manual Defrost for the cabinet(s). To access this mode, press the Service Switch, then press **41** on the numeric keypad.

Pressing either the ◀ or ▶ key will allow you to toggle back and forth between the fields.

Upon entering the Defrost setup mode, the display will show the current defrost settings. **Field A** is the cabinet selection field, use the # key to choose between cabinet 1 (1) or cabinet 2 (2). Then toggle to **Field B**, use the # key to set the defrost start time, in the 24 hour format. Then toggle to **Field C**, use the # key to choose between 6 or 8 hour time intervals between defrosting. To start an immediate defrost push the \* key, the display will show “Defrost Starts in 2 Minutes”. To exit this mode, press the **C** key or press the Service Switch.

## Mode 42 – Health Shutdown

Mode 42 is used to set the health shutdown options for the cabinet(s). To access this mode, press the Service Switch, then press **42** on the numeric keypad.

◆ **This mode applies to a machine that has been set to “CHILLER” in Mode 40 only. The health control in machines set to “FROZEN” or “FOOD” in Mode 40 is mandatory and CANNOT be turned off.**

Pressing either the ◀ or ▶ key will allow you to toggle back and forth between the fields.

Upon entering the health shutdown mode, the display will show the current health shutdown state. Use the numeric key pad to enter the selection numbers to be “health controlled” in **Field A**. Toggle to **Field B**, use the # key to turn the health shutdown on or off for the selected items. Repeat the above steps for each selection. If you would like a chime to sound when a health shutdown has occurred toggle to **Field C**, use the # key to turn the chime on or off. To exit this mode, press the **C** key or press the Service Switch.

### Special actions

◆ The \* key can be used as a wildcard in **Field A** to set entire rows (12\*) or the entire machine (1\*\*).

◆ **If the machine detects a Health Code error and the chime feature is ON the control board will sound a double beep every 30 seconds until the Health Code error is corrected.**

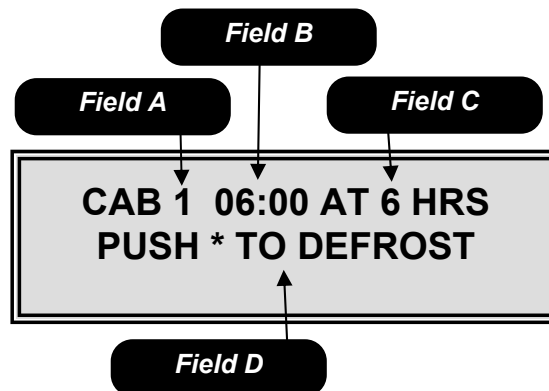

### Mode 41 - Defrost

**Field A** is the cabinet selection field.

**Field B** is the time in the 24 hour format to start the defrost cycle.

**Field C** is the interval in hours between each defrost cycle settable to 6 or 8.

**Field D** is the information to start an immediate defrost cycle.

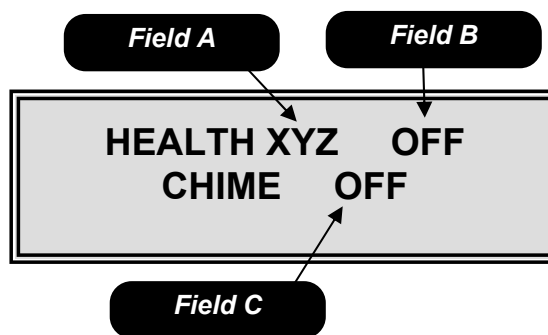

### Mode 42 – Health Shutdown

**Field A** is the item selection field.

**Field B** is the health shutdown on/off field.

**Field C** is used to turn on/off the health shutdown notification chime.

# Programming

## Mode 50 – Current Time

Mode 50 is used to set the current time date, date format and daylight saving options. To access this mode, press the Service Switch, then use the **Clock Fast Track Key** or press **50** on the numeric keypad.

Pressing either the ◀ or ▶ key will allow you to toggle back and forth between the fields.

Upon entering the Current Time mode, the display will show the current time (in 24 hour military time) and date settings. Use the numeric key pad to change the hour setting in Field A, then toggle to Field B and use the numeric key pad to set the minutes. Toggle to Field C, use the numeric key pad to set the month, then toggle to Field D, use the numeric key pad to set the day, then toggle to Field E, use the numeric key pad to set the year. Use the # key to save the settings to memory. Toggle to Field F; use the # key to choose the date format from the available options shown below. Toggle to Field G to change the daylight savings time zone setting using the available options shown below. To exit this mode, press the **C** key or press the Service Switch.

◆ **You must press the # key each time to save any changes to the time or date!**

### Field F available options

**MONTH/DAY** – This option will show the date in the Month/Day/Year format (mmdyy).

**DAY/MONTH** – This option will show the date in the Day/Month/Year format (ddmmy).

### Field G available options

**OFF** – Does not follow daylight savings time.

**N.AMER** – Will automatically adjust to North American daylight savings time with a 1 hour increase on the first Sunday in April and a 1 hour decrease the last Sunday in October.

**UK/EUR** – Will automatically adjust to European daylight savings time with a 1 hour increase on the last Sunday in March and a 1 hour decrease on the last Sunday in October.

**AUSLIA** – Will automatically adjust to Australian daylight savings time with a 1 hour increase on the last Sunday in October and a 1 hour decrease on the last Sunday in March.

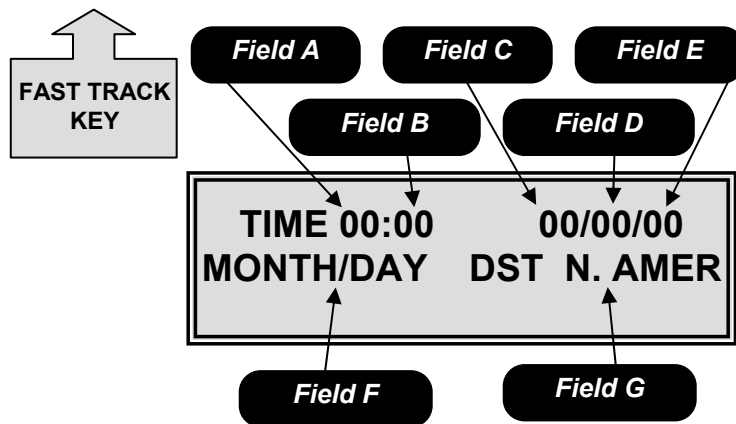

### Mode 50 – Current Time

**Field A** is the hour setting field (24 hour military time).

**Field B** is the minute setting field.

**Field C** is the month setting field.

**Field D** is the day setting field.

**Field E** is the year setting field.

**Field F** is the date format field.

**Field G** is the daylight savings selection field.

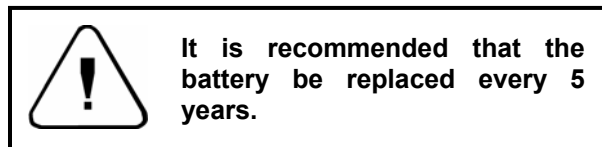

# Programming

## Mode 51 – Timed Shutdown

Mode 51 is used to set timed machine shutdown periods. The shutdown periods affect the ability of the machine to vend and the appearance of the machine. To access this mode, press the Service Switch, then use the **Set Shutdown Fast Track Key** or press **51** on the numeric keypad.

Pressing either the ◀ or ▶ key will allow you to toggle back and forth between the fields.

Upon entering the timed shutdown mode, the display will show the current shutdown setting. Use the # key in Field A to set the shutdown period number; this number may be set from 1 to 4 allowing for up to 4 different shutdown time periods per week. Toggle to Field B using the numeric key pad set the beginning hour then toggle to Field C and set the beginning minute (using 24 hour military time). Toggle to Field D using the numeric key pad set the ending hour then toggle to Field E to set the ending minute (using 24 hour military time). Toggle to Field F use the ◀ or ▶ keys to scroll between the days of the week, choosing which days the shutdown will occur on, use the # key to turn the days on (UPPERCASE) or off (lowercase). Toggle to Field G press the # key to reach screen 2. Field A on screen 2 references Field A on Screen 1 and should not be changed. Toggle to Field H use the # key to turn the shut down period on (Y) or off (N). Toggle to Field I use the # key to set the shutdown type from the available options shown below.

### Field I available options

**LIGHTS OFF** – this option is used to shut down the lights only. The machine will function in all other ways.

**VEND OFF** – this option shuts down the lights, disables vending by selection and if all selections are disabled credit acceptance will also be disabled during the shutdown period.

**LOW ENERGY** – this option will shut down the lights, vending will be allowed. In cabinets without health control enabled the temperature will be allowed to rise 5 degrees above the set point during the shut down period.

**TOT SHTDWN** – this option will shut down the lights, compressor (in non health control machines), vending, credit acceptance and the display are all shut off.

Toggle to Field J use the numeric key pad to enter the selection number the shutdown applies to, toggle to Field K and use the # key to change the N to Y, then toggle back to Field J and enter the remaining selections. You may use the # key while in Field J to scroll through the previous set selections. Field L may be used to return to Screen 1. To exit this mode, press the C key or press the Service Switch.

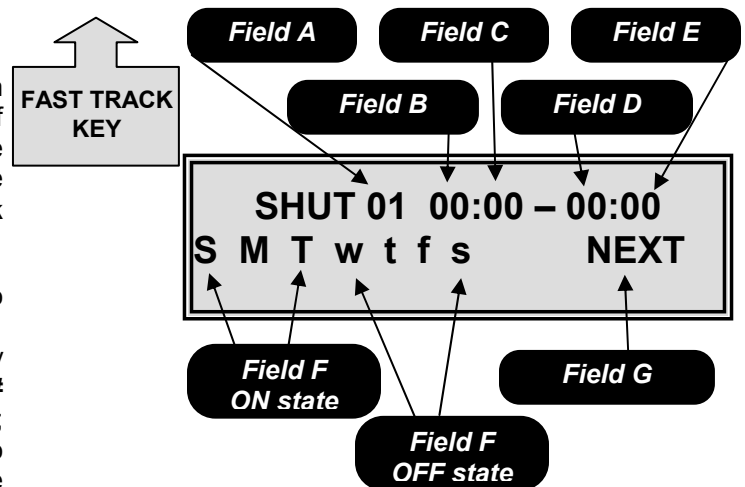

### Mode 51 – Timed Shutdown Screen 1

**Field A** is the shutdown number selection field.  
**Field B** is the shutdown starting hour set field.  
**Field C** is the shutdown starting minute set field.  
**Field D** is the shutdown ending hour set field.  
**Field E** is the shutdown ending minute set field.  
**Field F** is the day of the week selection field. In this example Sunday, Monday and Tuesday are ON and Wednesday, Thursday, Friday and Saturday are OFF.  
**Field G** is the move to the next screen field.

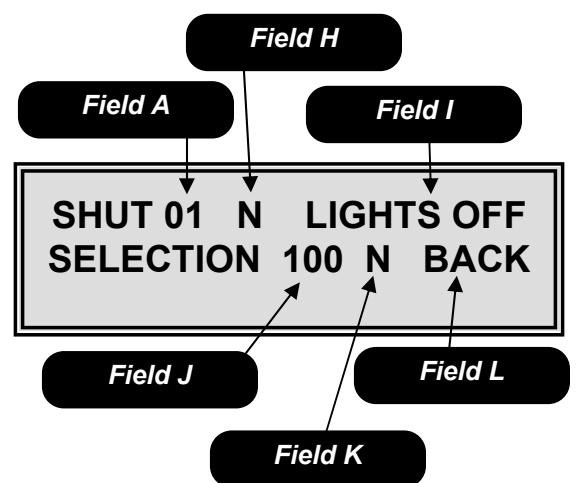

### Mode 51 – Timed Shutdown Screen 2

**Field A** is a reference to Field A on screen 1 and should not be changed.  
**Field H** is the shutdown on/off field.  
**Field I** is the shutdown type field.  
**Field J** is used to select item numbers for the shutdown.  
**Field K** is used to add/remove items from the shutdown.  
**Field L** is used to return to screen 1 in mode 51.

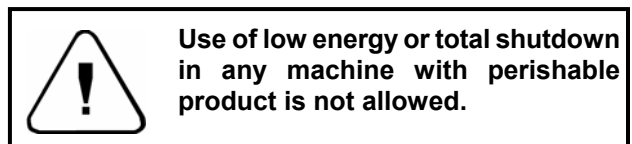

# Programming

## Mode 51 – Continued

### Special Actions

- ◆ The \* key can be used as a wildcard in Field J to set entire rows (12\*) or the entire machine (1\*\*).

### Note

- ◆ When the shutdown activates and only a portion of the machine is shut down, the display will scroll the message “**SELECTION XXX XXX XXX NOT AVAILABLE**” where XXX are the selections shut down, only 10 selections can be displayed if there are more than 10 a + sign will be added.
- ◆ In the Vend Off mode, if all selections are disabled the display will read “**MACHINE USE NOT ALLOWED UNTIL HH:MM**” where HH:MM is the time the shutdown is scheduled to shut off in Field B.
- ◆ Shutdown times in Field B and C must stay within a 24 hour clock: 00:00 to 23:59.

## Mode 52 – Timed Discount

Mode 52 is used to set timed discounts. To access this mode, press the Service Switch, then press **52** on the numeric keypad.

Pressing either the ◀ or ▶ key will allow you to toggle between the fields.

Upon entering the timed discount mode, the display will show the current timed discount settings. Use the # key in Field A to set the discount time period number; this number may be set from 1 to 4 allowing for up to 4 different discount periods per week. Toggle to Field B using the numeric key pad set the beginning hour then toggle to Field C and set the beginning minute (using 24 hour military time). Toggle to Field D using the numeric key pad set the ending hour, then toggle to Field E to set the ending minute (using 24 hour military time). Toggle to Field F, using the ◀ or ▶ keys to scroll between the days of the week, choosing which days the discount will occur on, use the # key to turn the days on (UPPERCASE) and off (lowercase). Toggle to Field G press the # key to reach screen 2. Field A on screen 2 references Field A on Screen 1 and should not be changed. Toggle to Field H use the # key to turn the discount period on (Y) or off (N). Toggle to Field I, and use the numeric key pad to set the discount dollar amount. Toggle to Field J use the numeric key pad to enter the selection number to be discounted, toggle to Field K and use the # key to change the N to Y, then toggle back to Field J and enter the remaining selections. You may use the # key while in Field J to scroll through the previous set selections. Field L may be used to return to Screen 1. To exit this mode, press the C key or press the Service Switch.

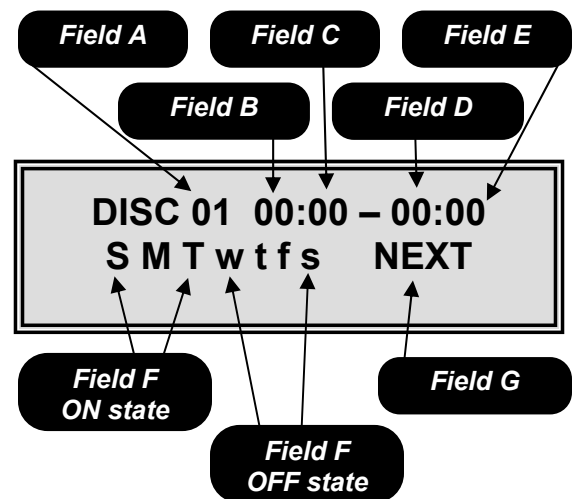

### Mode 52- Timed Discount Screen 1

**Field A** is the timed discount number selection field.

**Field B** is the timed discount starting hour set field.

**Field C** is the timed discount starting minute set field

**Field D** is the timed discount ending hour set field.

**Field E** is the timed discount ending minute set field.

**Field F** is the day of the week selection field. In this example Sunday, Monday and Tuesday are ON and Wednesday, Thursday, Friday and Saturday are OFF.

**Field G** is the move to the next screen field

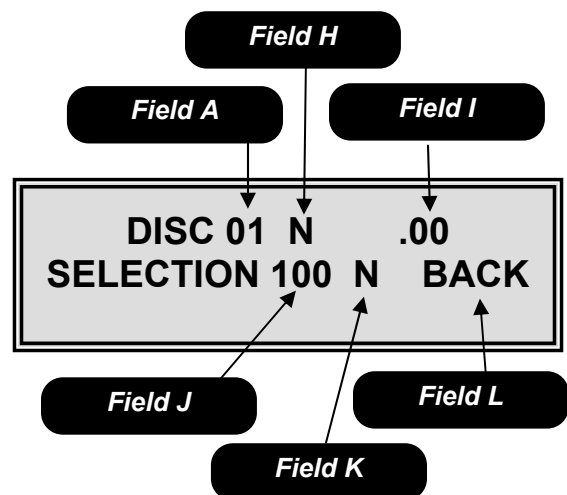

### Mode 52 – Timed Discount Screen 2

**Field A** is a reference to Field A on screen 1 and should not be changed.

**Field H** is the timed discount on/off field.

**Field I** is the discount amount field.

**Field J** is used to select item numbers for the timed discount.

**Field K** is used to add additional selection numbers to the timed discount list.

**Field L** is used to return to screen 1 in mode 52.

# Programming

## Mode 52 – Continued

### Special Actions

- ◆ The \* key can be used as a wildcard in Field J to set entire rows (12\*) or the entire machine (1\*\*).

### Note

- ◆ When the discount period becomes active, the display will scroll “SAVE \$.XX ON YYY YYY YYY” where xx is the dollar amount set in Field H and YYY is the items selected in Field I. A maximum of 10 selections will be displayed if more than 10 items a + will be added.
- ◆ Shutdown times in Field B and C must stay with in a 24 hour clock: 00:00 to 23:59.

## Mode 53 – Timed Messages

Mode 53 is used to set timed user messages. To access this mode, press the Service Switch, then press **53** on the numeric keypad.

Pressing either the ◀ or ▶ key will allow you to toggle back and forth between the fields.

Upon entering the timed user message mode, the display will show the current timed user message state. Use the # key in Field A to set the timed user message period number; this number may be set from 1 to 5 allowing for up to 5 different timed message periods per week. Toggle to Field B using the numeric key pad set the beginning hour then toggle to Field C and set the beginning minute (using 24 hour military time). Toggle to Field D using the numeric key pad set the ending hour then toggle to Field E and set the ending minute (using 24 hour military time). Toggle to Field F using the ◀ or ▶ keys to scroll between the days of the week, choosing which days the message will occur on, use the # key to turn on (UPPERCASE) or of (lowercase) the desired days. To exit this mode, press the **C** key or press the Service Switch.

### Note

- ◆ The times in Field B and C must stay with in a 24 hour clock (00:00 to 23:59).
- ◆ A user message must be set in Mode 60 before a timed message can be set. If no user messages are set, the default user message described in Mode 60 will be displayed.

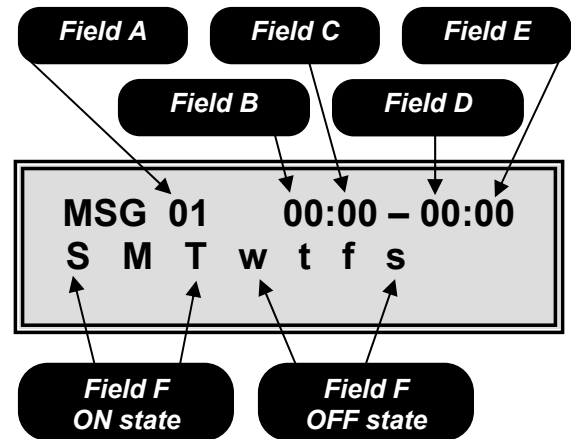

### Mode 53 – Timed Messages

**Field A** is the message select field.

**Field B** is the starting hour in 24 hour military time.

**Field C** is the starting minute in 24 hour military time.

**Field D** is the ending hour in 24 hour military time.

**Field E** is the ending minute in 24 hour military time.

**Field F** is the day selection field. In this example Sunday, Monday and Tuesday are on and Wednesday, Thursday, Friday and Saturday are off.

ENJOY A SNACK DURING LUNCH!

One Possible Timed Message

# Programming

## Mode 60 – User Message

Mode 60 is used to set a user message. To access this mode, press the Service Switch, then use the **Set Messages Fast Track Key** or press **60** on the numeric keypad.

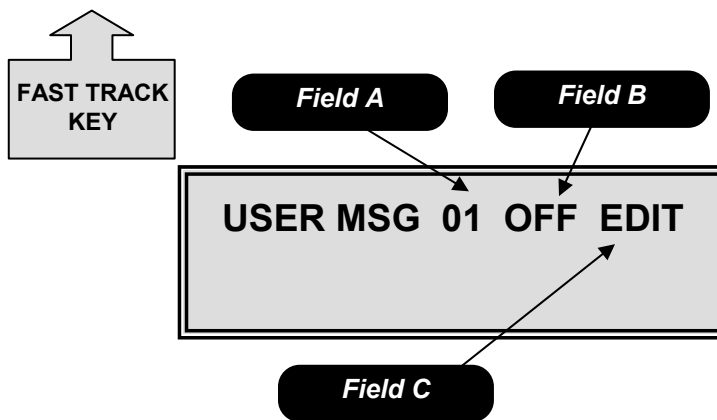

Pressing either the ◀ or ▶ key will allow you to toggle back and forth between the fields.

Upon entering the user message mode, the display will show the current user message state. Use the # key in Field A to select the user message number; this number may be set from 1 to 4 allowing for up to 4 programmable user messages. Toggle to Field B to select which line your message will be displayed on. Use the # key to choose from one of the available options shown below.

### Field B available options

**1** – Your message will be displayed on the top line of the display.

**2** – Your message will be displayed on the bottom line of the display.

**OFF** – Your message will not be displayed.

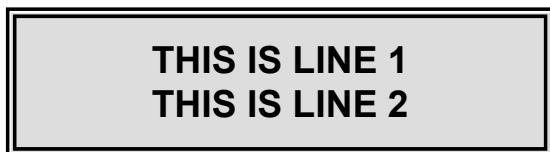

Toggle to Field C use the # key to enter the editing screen. Upon entering the edit screen the cursor will be flashing Field D. Field E is the edit instruction field use the keys shown, see below for additional information. When done editing press the # to save the message to memory. To exit this mode, press the C key or press the Service Switch.

### Edit Keys

**KEY 1** = to scroll up through the available characters.

**KEY 2** = to scroll down through the available characters.

**KEY 4** = will insert a duplicate of the currently selected character (flashing) and shift all characters to the right by one.

**KEY 5** = will delete the currently selected (flashing) character and shift all characters to the left by one.

**KEY 6** = will insert a flashing blank space to the left of the currently selected (flashing) character and shift all characters to the right by one.

### Note

- ◆ User message numbers 1 thru 4 are user programmable and each can be 100 characters in length.
- ◆ User message number 5 is the time and date message. This message cannot be changed.

### Mode 60 – User Message Screen 1

**Field A** is the user message select field.  
**Field B** is the display location selection field.

**Field C** is the enter edit screen field.

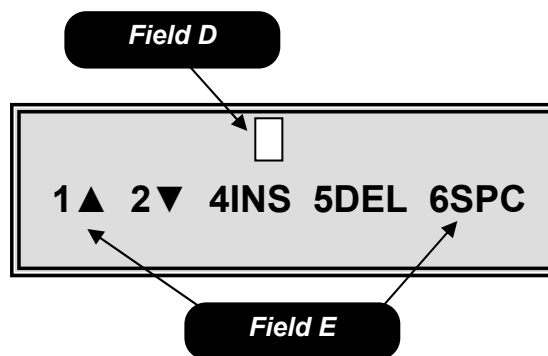

### Mode 60 – User Messages Screen 2

**Field D** represents the flashing cursor this is the position where characters will be added or deleted.

**Field E** is the editing instruction field.

Number	Message
01	HAVE A NICE DAY
02	HAVE A GREAT DAY
03	HAVE A GREAT DAY
04	Have a nice day
05	Current time/date setting
06	HAVE A NICE DAY

Default User Messages

- ◆ Choosing one of the graphic messages (7 through 14) in either line 1 or 2 will override any lower number message assigned.

# Programming

## Mode 60 – Continued

- ◆ User message number 6 is the factory default message. This message cannot be changed.
- ◆ If more than 1 user message is programmed for the same line, the message with the higher number will be displayed.
- ◆ When line 2 is not assigned to any message, it will show the message Credit .00, amount of deposited coins.

◆ The } character may be used as an end of message character in any text message greater than 10 characters in length.

◆ To save time scrolling through the available letters, insert an M then use the 4 key to insert several duplicate M's. This will give you a starting point in the middle of the alphabet.

Program #	Message	Image
#7	Hungry? Grab a snack and stay on track!	Scrolling train
#8	ENERGY to keep you on the run.	People running
#9	Guaranteed to deliver or your money back.	Golden Eye logo
#10	SNACK ATTACK	Shark scene
#11	Grand Central Energy Station – Refueling in progress!	Scrolling train
#12	Have no fear – satisfaction's served here! Guaranteed to deliver or your money back.	Superhero
#13	Have a great day!	Smiling faces
#14	Smart choices SERVED HERE!	

130 Series Graphic Display Pre-programmed Messages.

7A			11A
7B			11B
8A			12A
8B			12B
8C			12C
9A			13
9B			14A
10			14B

# Programming

## Mode 61 – After Sale Message

Mode 61 is used to customize the message that appears after each vend. To access this mode, press the Service Switch, then press **61** on the numeric keypad.

Pressing either the ◀ or ▶ key will allow you to scroll through the current message.

Upon entering the after sale message mode, the display will show the current message along with a flashing character in Field A. Field B is the edit instruction field, use the keys shown, see below for additional information. When done editing press the # key to save the message to memory. To exit this mode, press the **C** key or press the Service Switch.

### Edit Keys

**KEY 1** = to scroll up through the available characters.

**KEY 2** = to scroll down through the available characters.

**KEY 4** = will insert a duplicate of the currently selected character (flashing) and shift all characters to the right by one.

**KEY 5** = will delete the currently selected (flashing) character and shift all characters to the left by one.

**KEY 6** = will insert a flashing blank space to the left of the currently selected (flashing) character and shift all characters to the right by one.

### Note

- ◆ The after sale message may contain up to 80 additional characters.
- ◆ The after sale message will be appended for food/frozen machines with “PRESS COIN RETURN TO REOPEN DOOR”

## Mode 62 – Out of Service

Mode 62 is used to add additional information to the Out of Service message to aid your customers in the event a machine is out of order. To access this mode, press the Service Switch, then press **62** on the numeric keypad.

Pressing either the ◀ or ▶ key will allow you to scroll through the current message.

Upon entering the out of service message mode, the display will show the current out of service message along with a flashing character in Field A. Field B is the edit instruction field. Use the keys shown, see below for additional information. When done editing press the # key to save the message to memory. To exit this mode, press the **C** key or press the Service Switch.

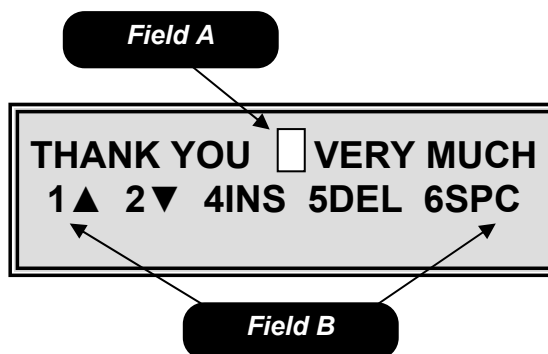

### Mode 61 – After Sale Message

**Field A** represents the flashing cursor this is the position where characters will be added or deleted.

**Field B** is the editing instruction field.



Default After Sale Message



One Possible After Sale Message

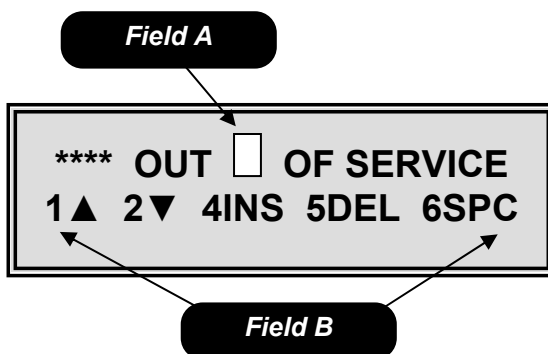

### Mode 62 – Out of Service

**Field A** represents the flashing cursor this is the position where characters will be added or deleted.

**Field B** is the editing instruction field.



# Programming

## Mode 62 – Continued

### Edit Keys

**KEY 1** = to scroll up through the available characters.

**KEY 2** = to scroll down through the available characters.

**KEY 4** = will insert a duplicate of the currently selected character (flashing) and shift all characters to the right by one.

**KEY 5** = will delete the currently selected (flashing) character and shift all characters to the left by one.

**KEY 6** = will insert a flashing blank space to the left of the currently selected (flashing) character and shift all characters to the right by one.

### Note

- ◆ The out of service message may contain up to 80 additional characters.
- ◆ The out of service message will only be displayed if the entire machine is out or service or if no motors or cabinets are available.

## Mode 63 – Alternate Language

Mode 63 is used to set an alternate language. To access this mode, press the Service Switch, then press **63** on the numeric keypad.

Upon entering the alternate language mode, the display will show the alternate language state. Press the **#** key to toggle between on and off. With the alternate language mode turned on all messages will be displayed in the alternate programmed language. To exit this mode, press the **C** key or press the Service Switch.

## Mode 80 – Test Vend

Mode 80 is used test vend the machine. To access this mode, press the Service Switch, then use the **Test Vend Fast Track Key** or press **80** on the numeric keypad.

Upon entering the test vend mode the display will show select. Use the numeric key pad to enter the selection in Field A (this field will be blank until a numeric key is pressed). If the selection motor tests ok the display will read “TEST PASSED” in Field B, if the motor failed the display will read “MTR ERROR” in Field B. To exit this mode, press the **C** key or press the Service Switch.



**Default Out of Service Message**



**One Possible Out of Service Message**

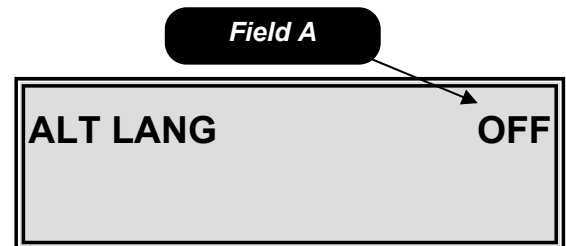

**Mode 63 – Alternate Language**  
*Field A* is the on/off field.

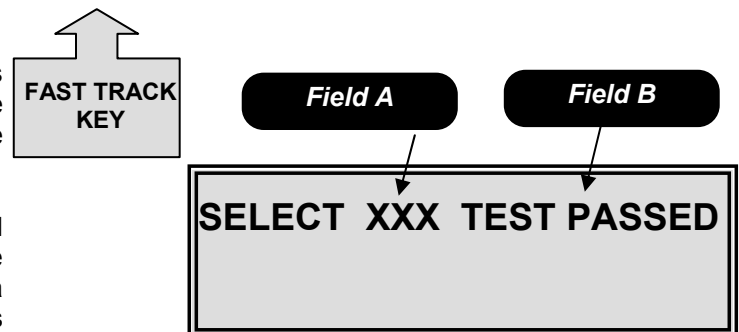

**Mode 80 – Test Vend**  
*Field A* is the item selection field. This field will be blank until a numeric key is pressed.  
*Field B* is the pass/fail field. If the motor passed it will read TEST PASSED if the motor failed it will read MTR ERROR.

# Programming

## Mode 81 – Sequential Event Log

Mode 81 is used to view the sequential event log. In this mode you are able to review the last 25 events that took place in the machine. To access this mode, press the Service Switch, then use the **Event Log Fast Track Key** or press **81** on the numeric keypad.

Upon entering the sequential event log, the display will show the last event that took place in the machine. Field A is the sequential event number. Field B is the event that took place (for an explanation of the abbreviation see table 7). Field C shows the selection number the event corresponds to (if applicable). Field D shows the date of the event. Field E shows the time of the event. Use the ◀ key to scroll through the previous sequential events (maximum of 25). Press # then the \* key to clear the sequential event log. To exit this mode, press the C key or press the Service Switch.

◆ The chime will sound 3 times when there are no more items to display.

DISPLAY	EVENT
CAB1 DR OPEN	Cabinet 1 Door Open
CAB1 DR CLS	Cabinet 1 Door Closed
CAB2 DR OPEN	Cabinet 2 Door Open
CAB2 DR CLS	Cabinet 2 Door Closed
PWR UP	Power UP
MTR XYZ	Run Motor XYZ
GE TRIG	Golden Eye Triggered
DEX	Machine Dexed
BAF OPEN	Baffle Door Open
BAF CLSD	Baffle Door Closed
EVNT CLEAR	Event Log Cleared
ERROR CLEAR	Error Log Cleared
MOTOR ERROR	Motor Error
PRICE SET	Price Set
TIME/DATE SET	Time Date Set
RESET ACCOUNT	Reset Accountability
HEALTH ERROR	Health Error
COMM ERROR	Communication Error
C1 DEFROST	Cabinet 1 Defrost
C2 DEFROST	Cabinet 2 Defrost

Table 7: Event list.

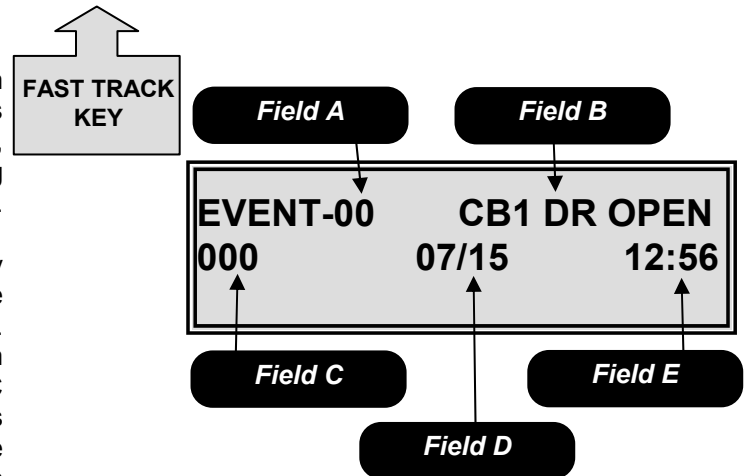

### Mode 81 – Sequential Event Log

**Field A** is the sequential event number.

**Field B** is the event name.

**Field C** is the selection number the event corresponds to if applicable.

**Field D** is the date of the event.

**Field E** is the time of the event.

# Programming

## Mode 82 – Service History

Mode 82 is used to view the service history. To access this mode, press the Service Switch, then use the **Service Log Fast Track Key** or press **82** on the numeric keypad.

Upon entering the service history mode, the display will show a service event in Field A. Field B shows you the duration time of the event if applicable; Field B may also show the selection number if applicable to the event in Field A. Field C shows you the time of the event. Field D shows the date of the event. Pressing either the ► key allows you to scroll through the service history events. To exit this mode, press the **C** key or press the Service Switch.

The service history events will be displayed in the following order.

1. The last 5 Cabinet 1 Door Openings, starting with the most recent.
2. The last 5 Cabinet 2 Door Openings, starting with the most recent.
3. The last 5 Motor Errors, starting with the most recent.
4. The last 5 Product Fall Errors, starting with the most recent.
5. The last 5 Health Errors.
6. The last 5 MIS Resets.
7. The last 5 Time/Date sets.
8. The last 5 Price Settings.
9. The last 5 Power Outages.
10. The last 5 Defrost Events.

◆ **The chime will sound 3 times when there are no more items to display.**

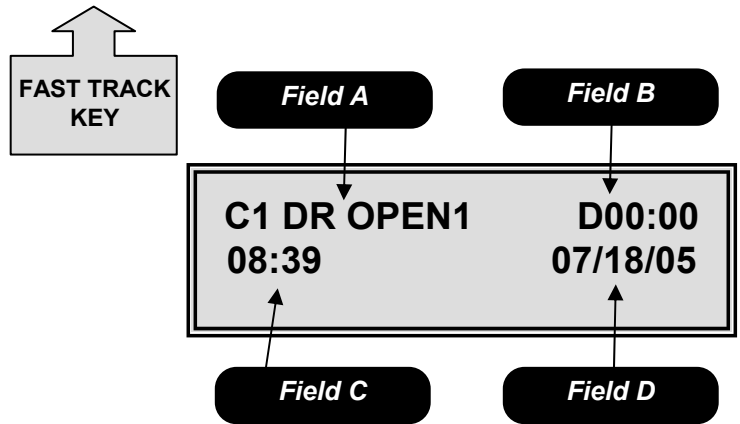

### **Mode 82 – Service History**

**Field A** is the event field.

**Field B** is the duration or selection field.

**Field C** is the time field.

**Field D** is date field.

# Programming

## Mode 83 – Temperature Log

Mode 83 is used to view the temperature log. To access this mode, press the Service Switch, then use the **Temp Log Fast Track Key** or press **83** on the numeric keypad.

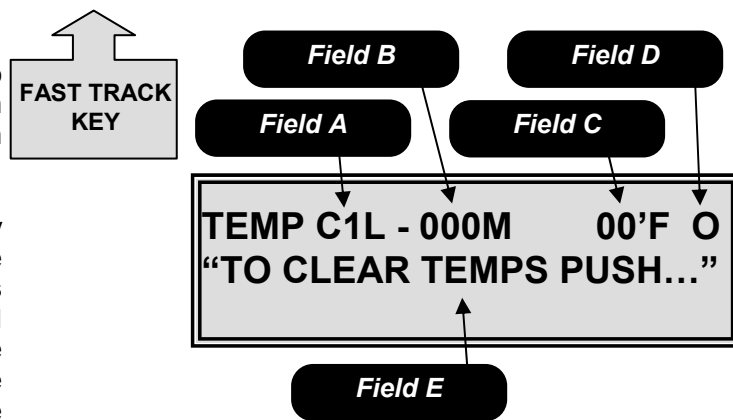

Upon entering the temperature log mode, the display will show the current temperature. Field A shows the cabinet and zone the data is referencing (in this example C1L is the lower zone of a chilled machine). Field B is the total minutes since the temperature was last taken. Field C shows the temperature. Field D shows the status of the refrigeration unit at the time the temperature was taken. See the list below for the available options for Field D.

### Available Options

- R** – Refrigeration was on.
- D** – Defrost was on.
- O** – Refrigeration was off.

Use the ◀ key to view the previous temperature samples which have been taken in 1 minute intervals. When the last sample is reached the display will show 'NO MORE TEMPS' in the first line and Field E will scroll the message "TO CLEAR TEMPS PUSH # THEN \* TO RUN REFRIDGERATION TEST PUSH 1". To clear the temperature log press # then \*. To run the refrigeration test push the 1 key. The display will change to "REF TEST ACTIVE". Upon completion of the test the display will show either

"REFER TEST PASS" or "REFER TEST FAIL". To exit this mode, press the **C** key or press the Service Switch.

◆ **The chime will sound 3 times when there are no more items to display.**

## Mode 84 – Baffle Door Test

Mode 84 is used to test the baffle doors. To access this mode, press the Service Switch, then press **84** on the numeric keypad.

In Field A use the # key to select which cabinet to perform the baffle test on. Press the **0** key to open the baffle door shown in Field B. Press the \* key to close the baffle door shown in Field C. To exit this mode, press the **C** key or press the Service Switch.

**Mode 83 – Temperature Log**  
**Field A** is the cabinet and zone indicator.  
**Field B** is the total minutes since the temperature was last taken.  
**Field C** is the temperature.  
**Field D** is the status of the refrigeration unit at the time the temperature was recorded.  
**Field E** is the scrolling instruction field.

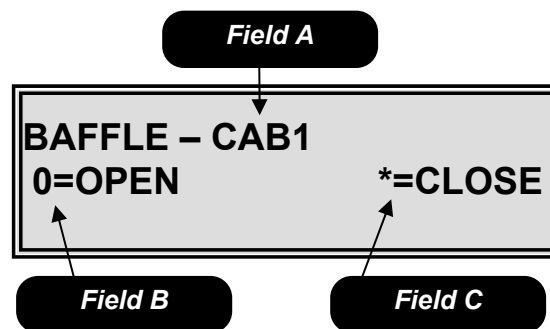

**Mode 84 – Baffle Door Test**  
**Field A** is the cabinet selection field.  
**Field B** is the open baffle door key.  
**Field C** is the close baffle door key.

# Programming

## Mode 85300 – Set Serial Number

Mode 85300 is used to set a serial number for retrieval during a print out or in the DEX data information. To access this mode, press the Service Switch, then press **85300** on the numeric keypad.

Upon entering the set serial number mode, the display will show the current set serial number. Use the numeric key pad to set a serial number (up to 17 characters in length). When done editing, press **#** to save the number to memory. To exit this mode, press the **C** key or press the Service Switch.

◆ This field appears in a DEX file as ID101

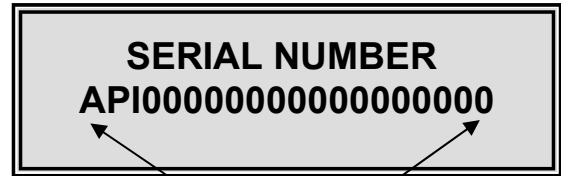

**Field A**

**Mode 85300 – Set Serial Number**  
**Field A** is the serial number set field.

## Mode 86200 – Set Machine ID

Mode 86200 is used to set a serial number for retrieval during a print out or in the DEX data information. To access this mode, press the Service Switch, then press **86200** on the numeric keypad.

Upon entering the set machine ID mode, the display will show the machine ID number that is currently set. Use the numeric key pad to set a machine ID number up to 20 characters in length. When done editing, press the **#** to save the number to memory. To exit this mode, press the **C** key or press the Service Switch.

◆ This field appears in a DEX file as ID102

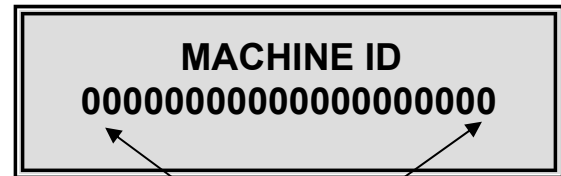

**Field A**

**Mode 86200 – Set Machine ID**  
**Field A** is the machine ID number set field.

## Mode 87400 – Set Location ID

Mode 87400 is used to set a location ID number for retrieval during a print out or in the DEX data information. To access this mode, press the Service Switch, then press **87400** on the numeric keypad.

Upon entering the location ID mode, the display will show the current location ID number. Use the numeric key pad to set a location ID number up to 20 characters in length. When done editing, press the **#** to save the number to memory. To exit this mode, press the **C** key or press the Service Switch.

◆ This field appears in a DEX file as ID104

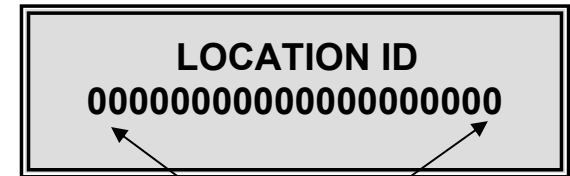

**Field A**

**Mode 87400 – Set Location ID**  
**Field A** is the location ID number set field.

# Programming

---

## Mode 88123456790 – Factory Test

Mode 88123456790 is used to run a factory test. To access this mode, press the Service Switch, then press **88123456790** on the numeric keypad.

After entering the factory test mode, the machine will automatically test the first vend motor, you must than press the **#** key to advance to the next motor to be tested. If a vend motor is not present or is bad, the test will stop and the display will flash in Field B one of the following: MISSING, OVER CURRENT or TIMEOUT. To continue with the test press the **#** key. Once the test is complete all options and prices will be reset to factory defaults.

◆ **Using this mode on a machine full of product will cause one of each item to vend.**

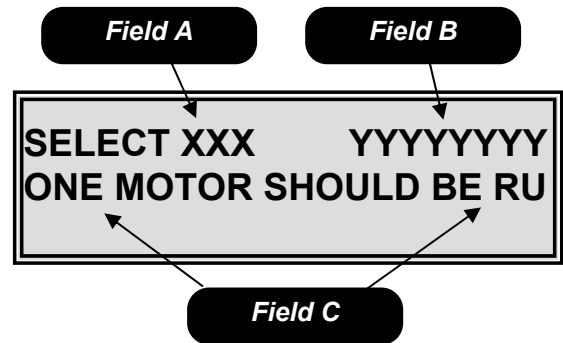

### **Mode 88123456790 – Factory Test**

**Field A** is the vend motor that is being tested.

**Field B** is the test information field.

**Field C** is the scrolling information field.

# Parts

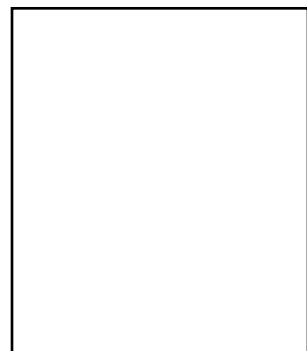
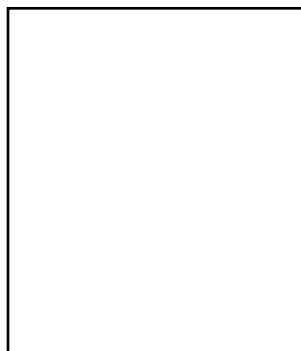
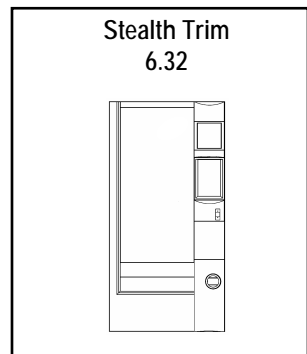
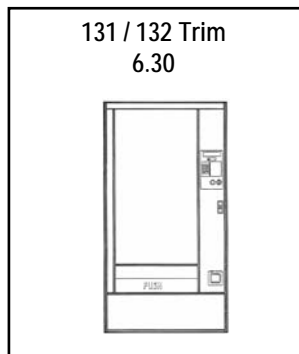
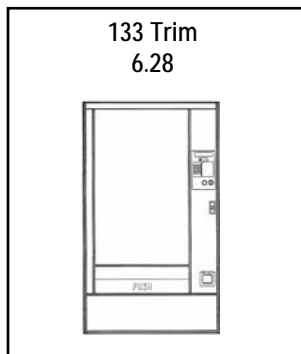
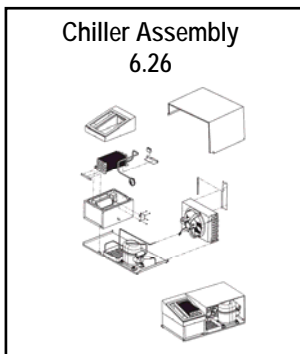
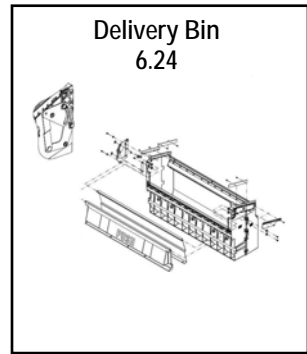
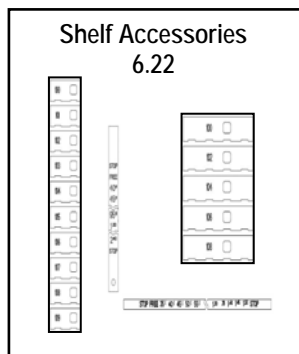
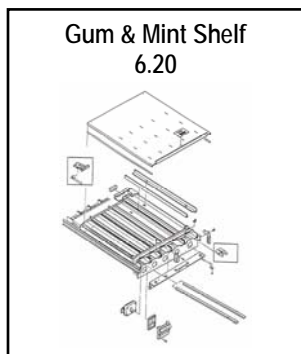
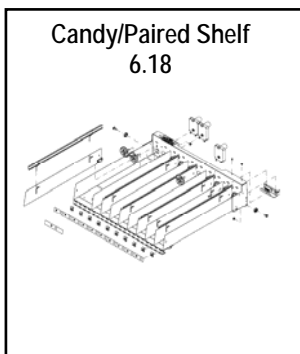
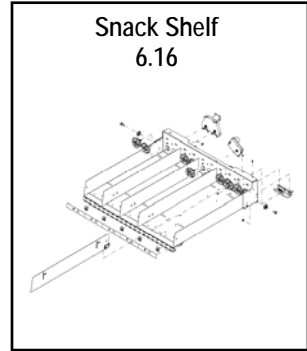
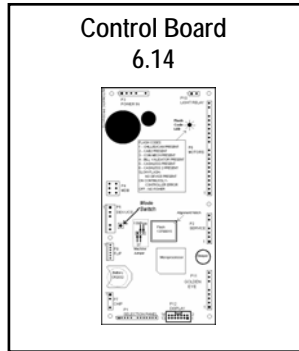
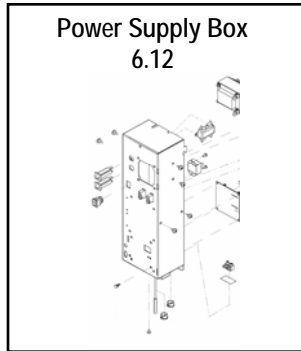
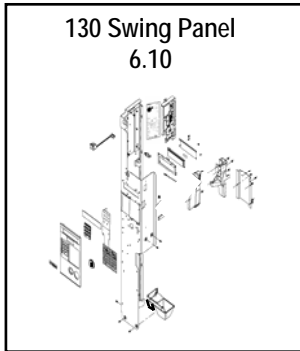
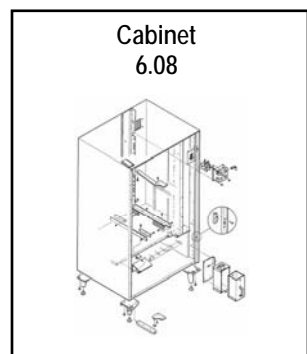
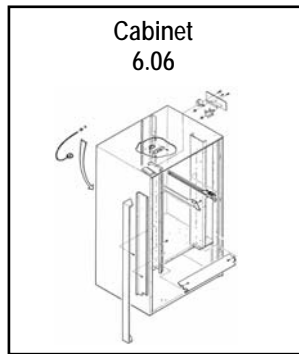
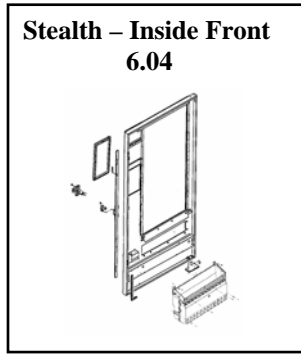
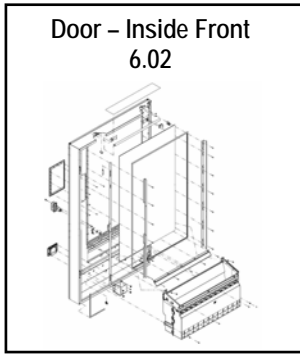

# Square & Euro Door – Inside Front

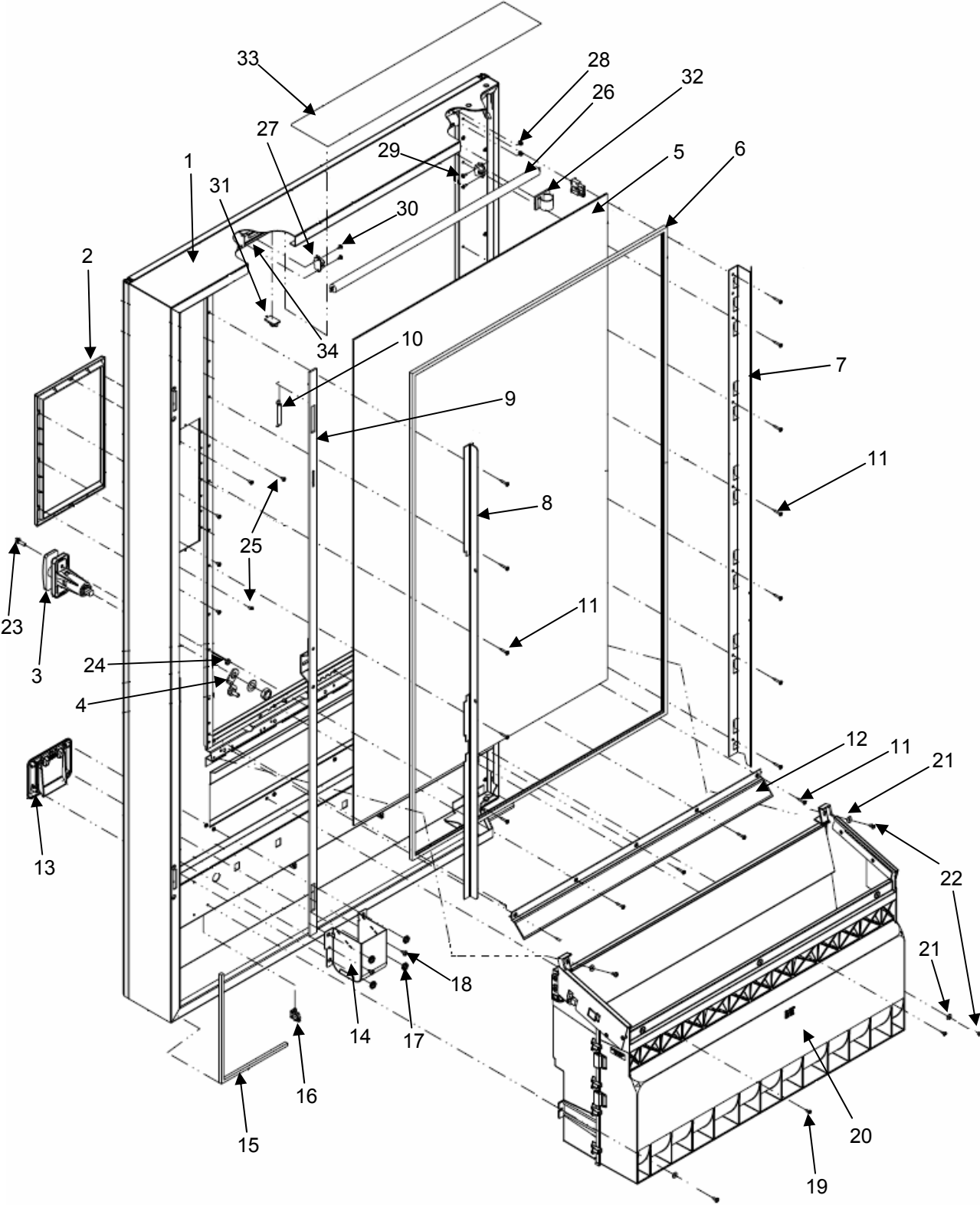



## Square & Euro Door – Inside Front

Key	Description	131	132	133
1	Door Weldment, Genesis Style	16000377	16000368	16000369
	Door Weldment, Genesis with POS	16000377-04	16000368-04	16000369-04
	Door Weldment, Stealth Style	16000380	16000374	16000375
	Door Weldment, Euro	16000379	16000372	16000373
	Other Styles Are Available Please Call!			
2	Trim Ring, Black w/o rib	440444	440444	440444-2
3	T-Handle Asm, Black	17200002-02	17200002-02	17200002-02
4	Lock Arm Asm	640123	640131	640131
5	Window, Front Ambient 44-5/8 x 21-9/16 x 1/8	750141-1	750141-1	
	Window, Front Ambient 44-5/8 x 26-7/8 x 1/8			750141
	<b>Note: Replacement Glass Must be Hard Tempered, Laminated Safety or Locally Obtained Lexan only.</b>			
	Window, Front Thermal Glass	750141-7	750141-7	750141-8
	Window, Laminated Safety Glass (optional)	750141-11	750141-11	750141-10
6	Edging, Window Ambient Glass, 143 Inches 133, 134 Inches 131 & 132	460436	460436	460436
	Edging, Window Thermal & Safety, 143 Inches 133, 134 Inches 131 & 132	13300007	13300007	13300007
7	Clamp, Window Hinge Side, Ambient	12000718	12000718	12000718
	Clamp, Window Hinge Side, Thermal & Safety	16000361	16000361	16000361
8	Clamp, Window Lock Side, Ambient	202807	202807	202807
	Clamp, Window Lock Side, Thermal & Safety	12000036	12000036	12000036
9	Locking Bar Asm	16000101	16000101	16000101
10	Spring, Locking Bar	400112	400112	400112
11	Screw Self Tap, .850 Long, Ambient	13100054-01	13100054-01	13100054-01
	Screw Self Tap, 1.200 Long, Thermal & Safety	13100054-02	13100054-02	13100054-02
12	Clamp, Window, Bottom, Ambient	12000674	12000674	16600467
	Clamp, Window, Bottom, Thermal & Safety	12000126	12000126	12000086
13	Trim, Coin Cup Asm	16600403	16600403	16600403
14	Coin Cup Asm, Security, Complete	16600280	16600280	16600280
	Coin Cup Asm, export	16600281	16600281	16600281
15	Foam, Adhesive Backed	460041	460041	460041
16	Wire Saddle, Locking Top	13100044	13100044	13100044
17	Nut, 1/4 Self Threading, Pal	18443	18443	18443
18	Screw, 8-32 x 5/16 PH/NIBS	276-8R5	276-8R5	276-8R5
19	Screw, Self Tap, .480 Long	13100054	13100054	13100054
20	Delivery Bin Asm, w/Golden Eye, See Page 6.24			
21	Washer, #8	600-8	600-8	600-8
22	Screw, 8-32 x 3/8 PN/NIBS	276-8R6	276-8R6	276-8R6
23	Bolt, 10-24 x 3/4 Carriage	118-10-12	118-10-12	118-10-12
24	Nut, 10-24 Keps	438-10	438-10	438-10
25	Screw, 6-32 x 1/4 Phillips Pan Head	116-6R4	116-6R4	116-6R4
26	Fluorescent Lamp, F24T5/841/HO	26900004	26900004	26900004
27	Harness Asm, High Output Light	16800149	16800149	16800149
28	Nut, 6-32 Keps ZN	438-6	438-6	438-6
29	Screw, 6-32 x 3/8 Phillips Pan Head	276-6R6	276-6R6	276-6R6
30	Screw, 6-32 x 1/4 Phillips Pan Head	276-6R4	276-6R4	276-6R4
31	Cord Clip, Adhesive Back	420097	420097	420097
32	Cable Clamp, Adhesive Back, 1/2 inch	420096-1	420096-1	420096-1
33	Tape, Reflective, 4 x 22 3/4	17400177	17400177	17400177
34	Bracket, Top Window, Ambient	12000741	12000741	12000741
	Bracket, Top Window, Thermal & Safety	12000741-01	12000741-01	12000741-01

# Stealth Door – Inside Front

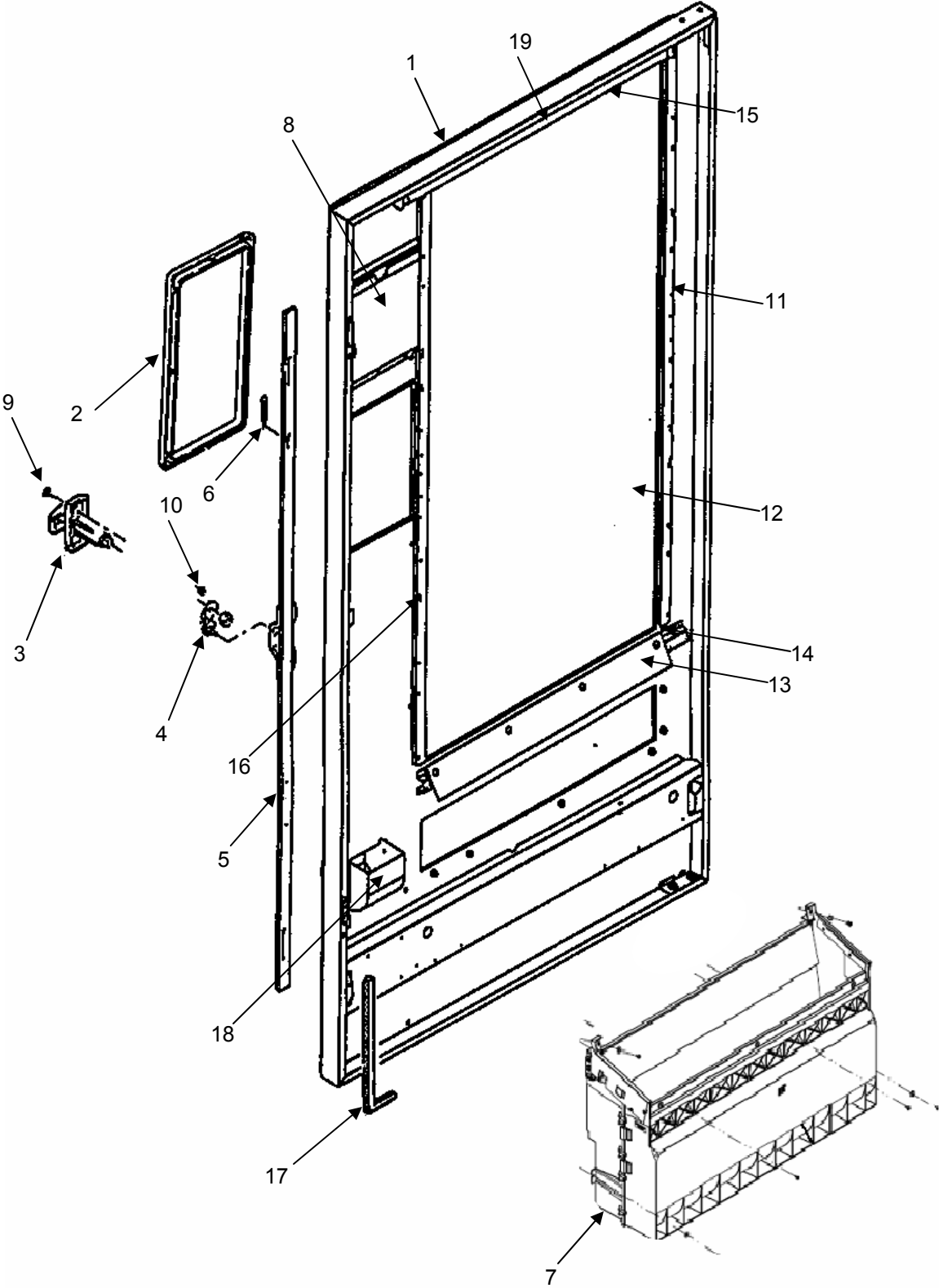

## Stealth Door – Inside Front

Key	Description	131	132	133
1	Door Weldment, Ambient	16000380	16000374	16000375
	Door Weldment, Thermal	16000380-01	16000374-01	16000375-01
2	Trim Ring Bezel, Coin Insert	38527-1	38527-1	38527-1
3	T-Handle and Lock Asm (includes 3A & 4)	16600113-01	16600114-01	16600114-01
3A	T-handle Asm, w/o latch	38332-2	38332-2	38332-2
	Shim, T-Handle	22000190	22000190	22000190
4	Lock Arm	16400013	16400012	16400012
5	Lock Bar, Asm	16000103	16000103	16000103
6	Spring, Lock Bar	400112	400112	400112
7	Delivery Bin Asm, w/Golden Eye, See Page 6.24			
8	POS Asm, Complete See Page 6.32 for Itemized Breakdown	16600444	16600444	16600444
9	Carriage Bolt, #10-24	118-10-8	118-10-8	118-10-8
10	Nut, Hex, #10-24	404-10	404-10	404-10
11	Clamp, Window Hinge Side, All Glass Styles	12000193	12000193	12000193
12	Window, Front Ambient 44-5/8 x 21-9/16 x 1/8	750141-1	750141-1	
	Window, Front Ambient 44-5/8 x 26-7/8 x 1/8			750141
	<b>Note: Replacement Glass Must be Hard Tempered, Laminated Safety or Locally Obtained Lexan only.</b>			
NS	Window Edging, Ambient, 143 inches for 133, 134 inches for 131 & 132	460436	460436	460436
	Window, Front Thermal Glass*	750141-7	750141-7	750141-8
	Window, Laminated Safety Glass*	750141-11	750141-11	750141-10
NS	Window Edging, Thermal & Safety, 143 inches 133, 134 inches for 131 & 132	13300007	13300007	13300007
13	Clamp, Bottom Window, All Glass Styles	16600470	16600470	16600469
14	Support, Lower Window, Ambient	202462-1	202462-1	202462
	Support, Lower Window, Thermal & Safety	12000263-01	12000263-01	12000263
15	Window, Bracket Top, Ambient	12000741	12000741	12000741
	Window, Bracket Top, Thermal & Safety	12000741-01	12000741-01	12000741-01
16	Window, Bracket Lock Side, Ambient	12000812	12000812	12000812
	Window, Bracket Lock Side, Thermal & Safety	12000812-01	12000812-01	12000812-01
17	Foam, Adhesive Backed	460041	460041	460041
18	Coin Cup Asm, Security	16000455	16000455	16000455
	Coin Cup Door	38529-1	38529-1	38529-1
	Coin Cup Door Axle	38530	38530	38530
	Coin Cup, Security, Export	16600455-01	16600455-01	16600455-01
19	Fluorescent Lamp, F24T5/841/HO	26900004	26900004	26900004
NS	Wire Guard	12000840	12000840	12000840
NS	Screw, Plastite #7 x 1/2, 25 Required	305-7R8	305-7R8	305-7R8
NS	Screw, Pan head 8-32 X 3/8, 7 Required	276-8R6	276-8R6	276-8R6
NS	Screw, Pan Head, 6-32 x 1/4, 9 Required	276-6R4	276-6R4	276-6R4
NS	Screw, Pan Head, #8 x 1, Thermal Window, 9 Required	218-8R16	218-8R16	218-8R16
NS	Nut, 8-32 Keps, 6 Required	438-8	438-8	438-8
NS	Ferrule, 13 Required	420144	420144	420144
*	Optional Items			
NS	Item Not Shown			

# Cabinet

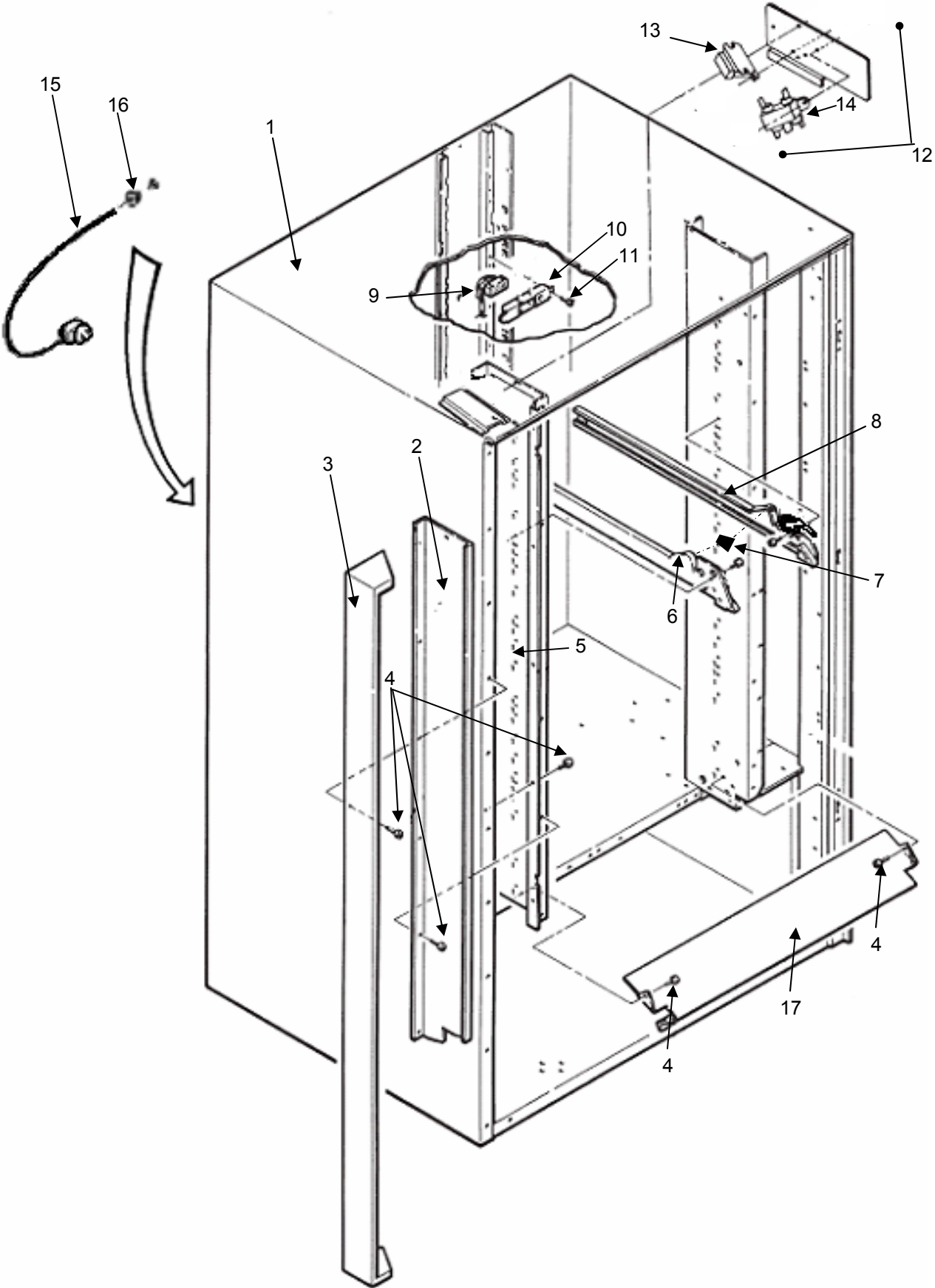

# Cabinet

Key	Description	131	132	133
1	Cabinet Asm, Complete w/legs. See Page 6.05			
	Chill Cabinet Asm, Complete w/legs, See Page 6.05.			
2	Filler Plate, Left Front	12000825	12000825	12000825
3	Door Filler, Specify Color	N/A	600310	600310
4	Screw, 8-32 x 3/8 Pan Head	276-8R6	276-8R6	276-8R6
5	Shelf Support, Left Front	12000819	12000819	12000819
6	Assembly, Shelf Cabinet Track, Left	16400077-01	16400077	16400077
7	Rail Insert, Left or Right, Used on Bottom 2 Shelves Only	14400128	14400128	14400128
7A	Screw, Undercut Flat Head for Rail Insert	13100060	13100060	13100060
8	Assembly, Shelf Cabinet Track, Right	16400075-01	16400075	16400075
9	Harness, Cabinet Back, Asm Complete	16600456	16600456	16600456
10	Mounting Bracket Only, Cab Back Harness, Solid Mounting Type	12000173	12000173	12000173
10A	Mounting Bracket Only, Cab Back Harness, Floating Type	12000863	12000863	12000863
11	Screw, 8-32 x 3/8, Use With item 10	276-8R6	276-8R6	276-8R6
11A	Screw, 8-32 x 3/8, Use With Item 10A	13100064	13100064	13100064
12	Assembly Complete, High Efficiency Light Ballast & Filter T5 120V	16600442	16600442	16600442
13	Ballast w/Harness, F24T5HO	16800146	16800146	16800146
14	Line Filter	380303	380303	380303
15	Line Cord, 120V US	16800052-02	16800052-02	16800052-02
	<b>Line Cord, 120V Export</b>	<b>680459</b>	<b>680459</b>	<b>680459</b>
	<b>Line Cord, Europe</b>	<b>680501-1</b>	<b>680501-1</b>	<b>680501-1</b>
	<b>Line Cord, Australia</b>	<b>380275-1</b>	<b>380275-1</b>	<b>380275-1</b>
	<b>Line Cord, Israel</b>	<b>680544-1</b>	<b>680544-1</b>	<b>680544-1</b>
	<b>Line Cord, UK</b>	<b>680578-1</b>	<b>680578-1</b>	<b>680578-1</b>
	<b>Line Cord, India</b>	<b>16800043</b>	<b>16800043</b>	<b>16800043</b>
16	Bushing, Strain Relief	380052-2	380052-2	380052-2
17	Filler Panel, Gum & Mint, for use with no Gum & Mint	12000121-02	12000121-02	12000121

# Cabinet

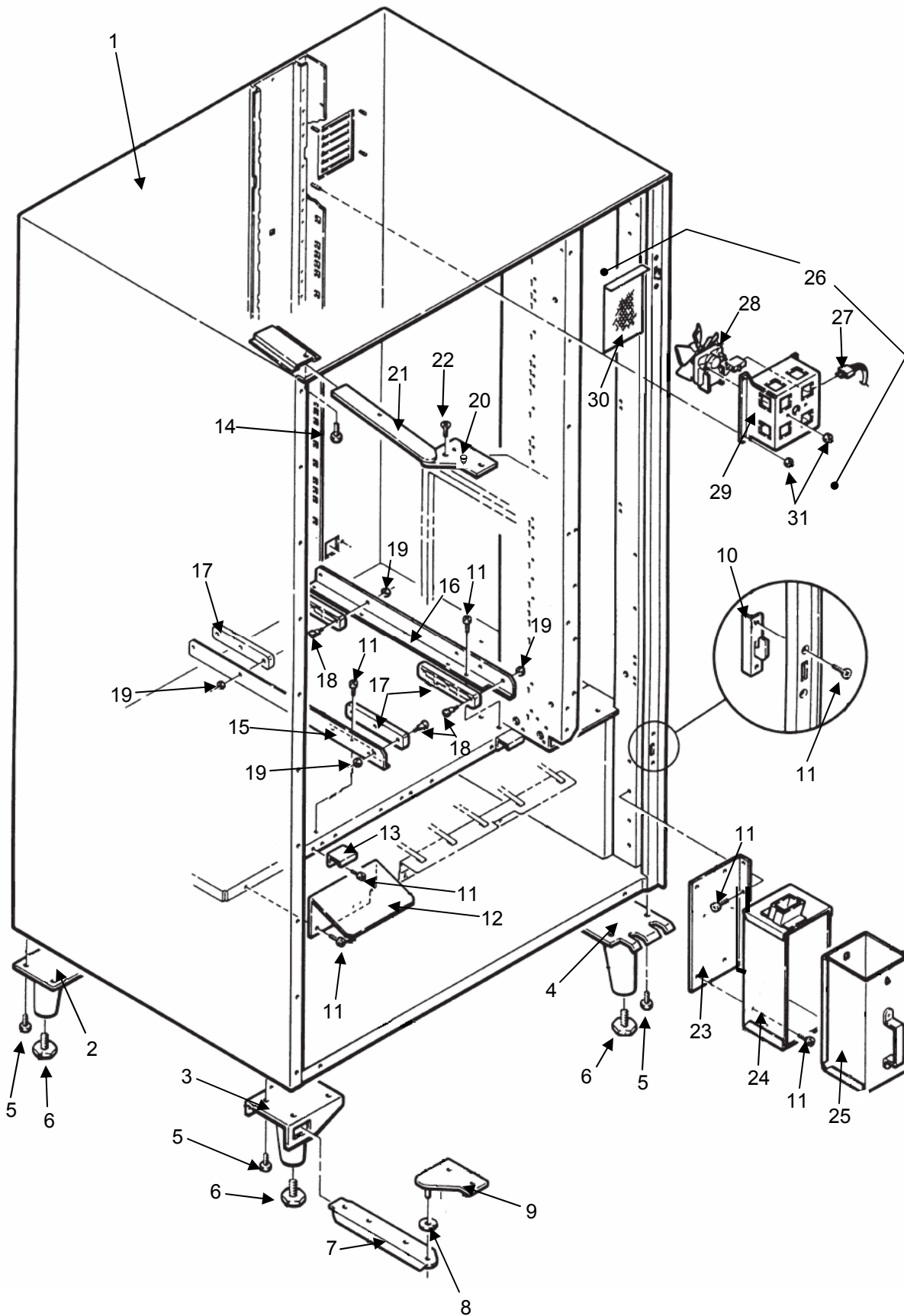

# Cabinet

Key	Description	131	132	133
1	Cabinet Asm, Complete w/legs. Specify Color			
	Chill Cabinet Asm, Complete w/legs, Specify Color			
2	Rear Leg Asm, Specify Color	600195	600195	600195
3	Front Leg Asm, Pivot Side, Specify Color	600195	600195	600302
4	Front Leg Asm, Lock Side, Specify Color	600197	600197	600197
5	Screw, Hex Head 5/16 -18 x 3/4	420187	420187	420187
6	Leg Leveler	300103	300103	300103
7	Lower Hinge Support, Specify Color	201773	202088	202088
8	Washer	420010-23	420010-24	420010-24
9	Lower Hinge, Pivot Asm	640157	640154	640154
10	Door Catch Asm	12000290	12000290	12000290
11	Screw, Pan Head, 8-32 x 3/8	276-8R6	276-8R6	276-8R6
12	Plate, Gum & Mint Deflector	12000038-01	12000038-01	12000038
13	Catch, Gum & Mint Tray	12000006	12000006	12000006
14	Screw, Hex head, 5/16-18 x 7/16	N/A	164-51-7	164-51-7
14A	Nut, Keps ¼-20	438-41	438-41	N/A
15	Assembly Complete, Gum & Mint Support, Left	16600039-03	16600039-01	16600039-01
15A	Rail, Gum & Mint Support, Left	12000061-03	12000061-01	12000061-01
16	Assembly Complete, Gum & Mint Support, Right	16600039-03	16600039-01	16600039-01
16A	Rail, Gum & Mint Support, Right	12000061-02	12000061	12000061
17	Slide, gum & Mint Tray	440278	440278	440278
18	Screw, Shelf Roller	300137	300137	300137
19	Nut, ¼-28 Keps	437-41	437-41	437-41
20	Screw, Hinge Stop	N/A	13100057	13100057
21	Upper Hinge Asm	640150	16400079	16400079
22	Screw, 1/4-20 x 1/2	13100035	13100035	13100035
23	Support, Cash Box	202809	202809	202809
24	Assembly, Cash Box Mounting	16600150-01	16600150-01	16600150-01
25	Cash Box, Plastic	14400047	14400047	14400047
26	<b>The following parts are available for machines with the factory installed fan option only!</b>			
27	Harness, Fan	680456-1	680456-1	680456-1
28	Fan, Motor Only, 117 Volt	360122-2	360122-2	360122-2
	Fan, Motor Only, 230 Volt	360122-3	360122-3	360122-3
29	Fan, Housing Only	202072	202072	202072
30	Fan, Perforated Plate	12000275	12000275	12000275
31	Nut, 6-32 Hex	404-6	404-6	404-6

# 130 / Swing Panel

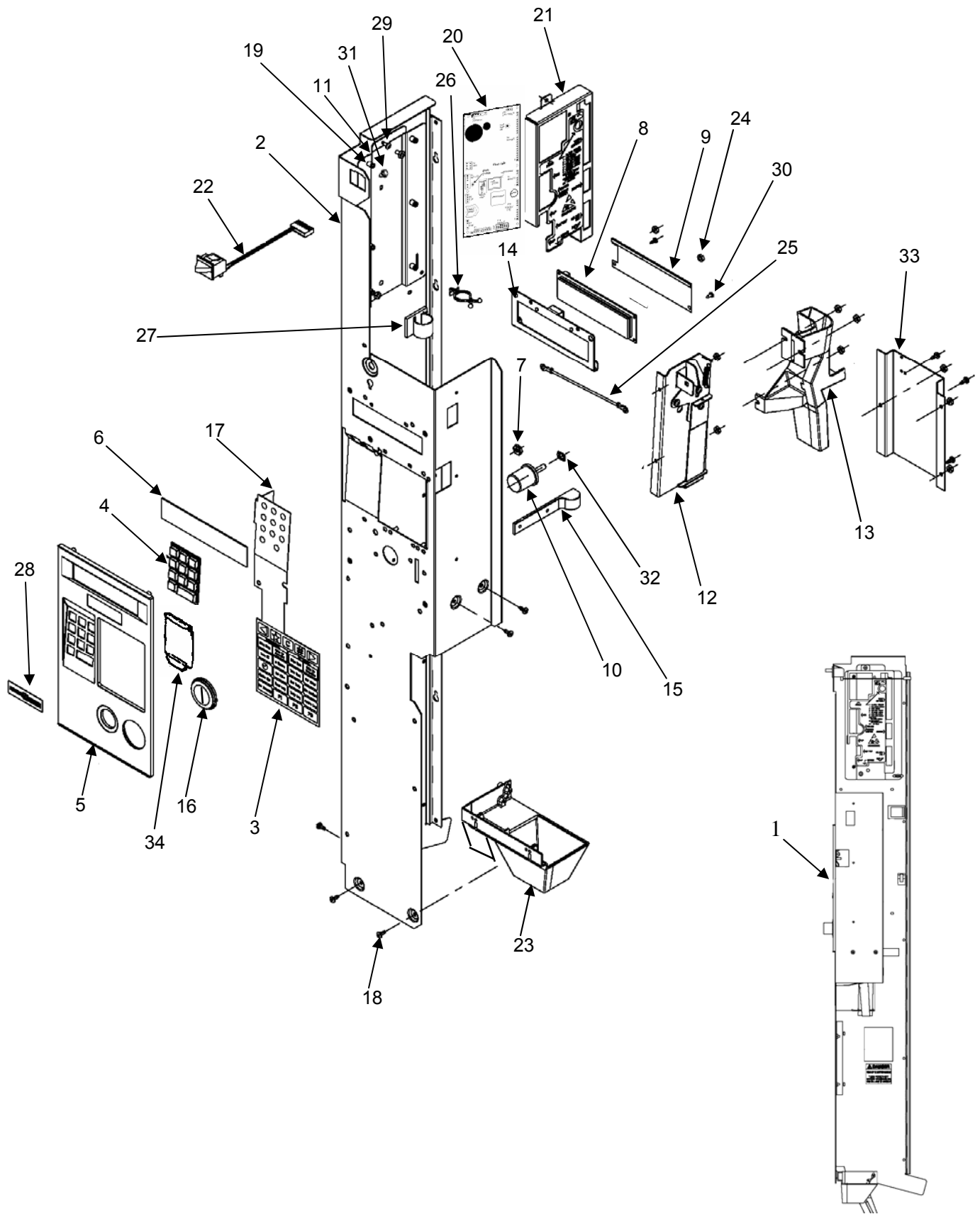



# 130 / Swing Panel

Key	Description	Part No.
1	Swing Panel Assembly Complete	16600493
2	Swing Panel Riveted Assembly	16400092
3	Selection Switch, English/Spanish	13800002-01
3A	Decal, Braille Selection	17400179
4	Keypad, Dk Gray, with Braille	14400015-01
5	Selector Bezel, Black	440442
6	Display Window	14400112
7	Pal Nut, ¼ Self Threading	18443
8	Display,	13600018
9	Insulator, Display Board	14400062
10	Button, Coin Return, Euro Gray	440289-5
11	Bracket, Control Board Mounting	12000744
12	Coin Return Assembly	16600430
13	Chute, Coin Entry	16600437
14	Bracket, Display Mounting	12000515
15	Latch, Swing Panel	14400127
16	Coin Insert (USA, El Salvador, Ethiopia, Tahiti)	440445-5
	Coin Insert (Chile, Brazil, France, Germany, Taiwan)	440445-6
	Coin Insert (UK, Turkey, Panama, Columbia, China, Peru, Sweden, South Africa, Saudi Arabia)	440445-7
	Coin Insert (Australia, New Zealand, Italy, Lebanon, Mexico, Holland, Israel, Malaysia, Tunisia, Singapore, Oman, Uruguay, Denmark, Philippines, United Arab Emirate)	440445-9
	Coin Insert – No Slot	440445-11
17	Harness Extension, Selection Switch	16800148
18	Screw, 8 x 3/8 Pan Head Plastite	305-8R6
19	Standoff, Circuit Board ¼ inch	17100003
20	Control Board, ST/130	13600024
21	Cover, Control Board Assembly	16600386
22	Harness, Door Switch Assembly	660666
23	Chute Assembly, Coin Exit	16600424
	Chute Assembly, Coin Exit, Stealth	16600450
24	Keps Nut 8-32	438-8
25	Ground Wire	680455-4
26	Wire Clamp, Twist Lock .75 Bnd	13100056
27	Cable Clamp, Adhesive Back ¾ inch	420096
28	AP Logo Plate	17400141
29	Screw, 8-32 x 3/8 Pan Head	276-8R6
30	Screw, 6 x 3/8 Pan Head	200-6R6
31	Screw, 6 x ½ Pan Head	218-6R8
32	Speed Nut	420082
33	Bracket, Coin Mech	12000881
34	Validator Blocking Plate	660580

# Power Supply Box

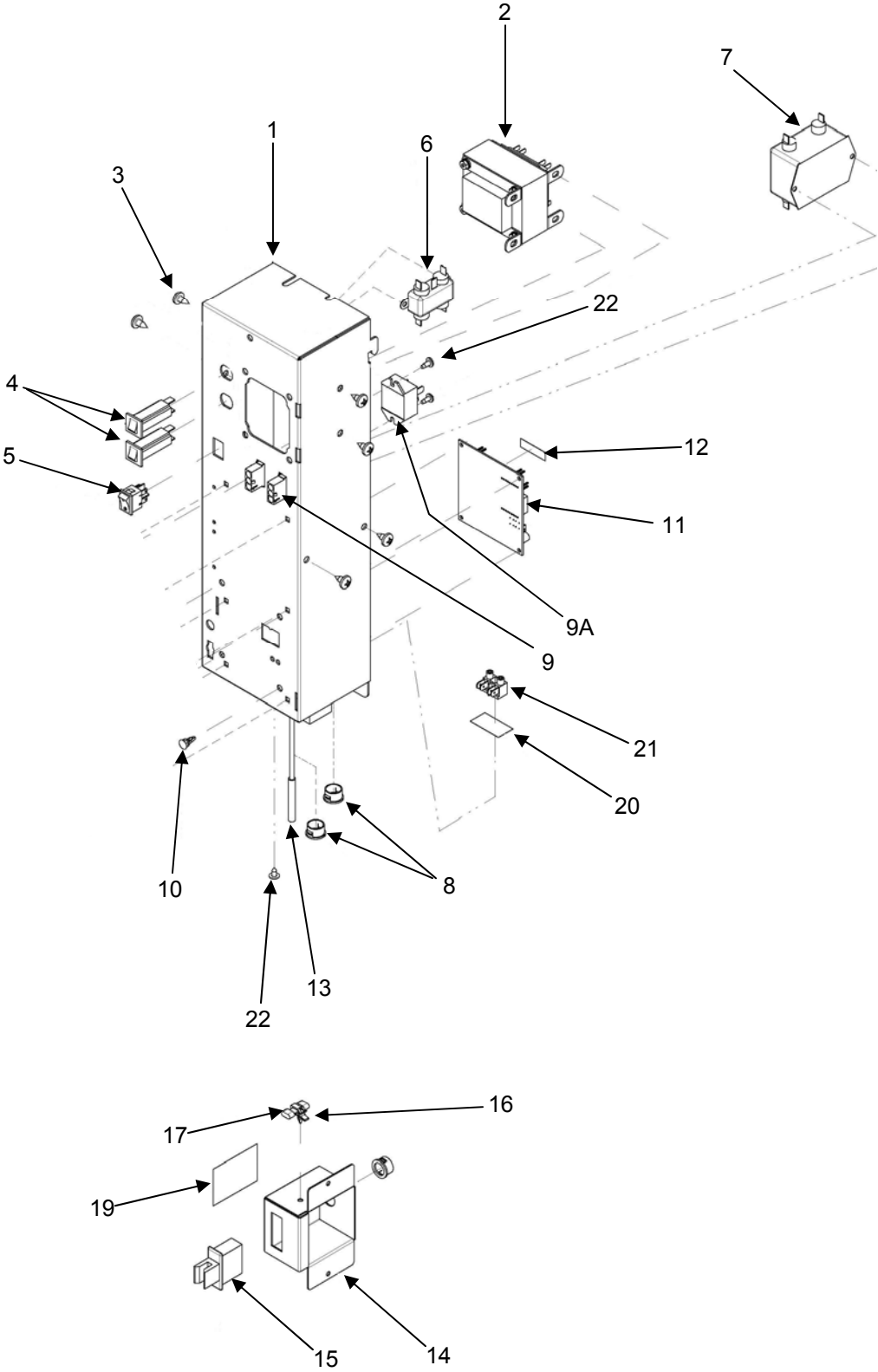

# Power Supply Box

Key	Description	120v Ambient USA	120V Chilled USA	120V Ambient Export	120V Export Chill	230V Ambient Export	230V Export Chill
1	Power Box assembly	16600385	16600405	16600406	16600407	16600408	16600409
	Junction Box Weldment ST/130	12000800	12000800	12000800	12000800	12000800	12000800
2	Transformer 120v/230v ST	13900006	13900006	13900006	13900006	13900006	13900006
3	Screw Pn/Nibs Hd 1/4x1/2	216-41R8	216-41R8	216-41R8	216-41R8	216-41R8	216-41R8
4	Circuit Breaker 3 Amp	380241	380241	380241	380241	380241	380241
5	Switch Rocker	380243	380243	380243	380243	380243	380243
6	Filter-Light	380303	380303	380303	380303	380303	380303
7	RFI Filter-Line		380304		380304		380304
8	Snap Bushing 1/2 Hole	420040-2	420040-2	420040-2	420040-2	420040-2	420040-2
9	Harness Junction Box	16800138	16800139	16800140	16800141	16800143	16800144
9A	Light Relay	16700030	16700030	16700030	16700030	16700030	16700030
10	Circuit Board Standoff		17100002		17100002		17100002
11	PCB Dual Temp Cold Control		13600005-01		13600005-01		13600005-01
11A	Chiller Board to MDB harness		680659-1		680659-1		680659-1
12	Warranty Label		460339		460339		460339
13	Temperature Probe		13600001-02		13600001-02		13600001-02
14	Door Switch Box			12000122	12000122	12000122	12000122
15	Door Switch, Foreign C.T.			380262	380262	380262	380262
16	Wire Saddle Side Entry			380321	380321	380321	380321
17	Cheat Interlock Tool			380263	380263	380263	380263
18	Cable Tie (Not Shown)			380078	380078	380078	380078
19	Decal Voltage Disconnect			460642	460642	460642	460642
20	Mylar Insulation-Contactor			440065	440065	440065	440065
21	Terminal Block			380285	380285	380285	380285
22	#8x3/8 Ph Tr/Nibs Hd BI Max(A)			210-8R6	210-8R6	210-8R6	210-8R6
23	Dome Plug 5/8 Hole (Not Shown)	420040-1	420040-1				
24*	Harness DEX/UCS Chassis Mount	16800044	16800044	16800044	16800044	16800044	16800044
25*	Harness Touch Memory	16800013	16800013	16800013	16800013	16800013	16800013
*	Optional items						

# Control Board

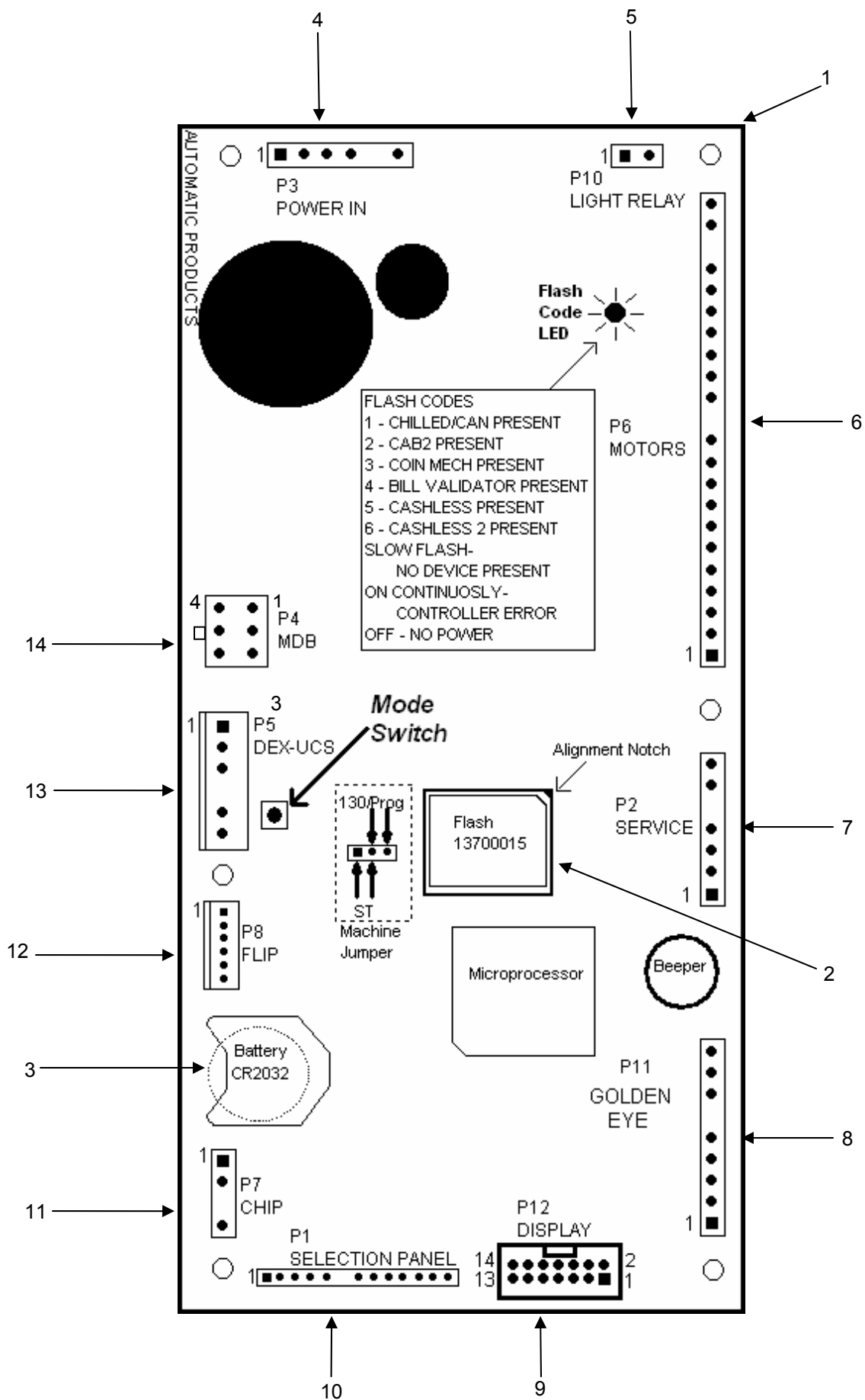

# Control Board

Key	Description	Part No.
1	Control Board.	13600024
2	Flash Memory Chip.	13700015
3	Battery CR2032. 3 Volt (available locally).	17100007
4	Power Box Harness	See page 6.12
5	Power Box Harness	See page 6.12
6	Cabinet Back Harness, Assembly Complete,	16600456
7	Door Switch Harness	680632
8	Golden Eye Harness, Assembly Complete.	16800150
9	Display/Keypad Harness, Assembly Complete.	16800148
10	Display/Keypad Harness, Assembly Complete.	16800148
11	Touch Memory Harness	16800013
12		
13	DEX/UCS Harness Assembly, Chassis Mount.	16800044
	DEX/UCS Harness Assembly, Loose	680509
14	Display/GE/Keypad/MDB Harness, Assembly Complete.	16800142

## 130 Cabinet Back Harness Color Code Chart

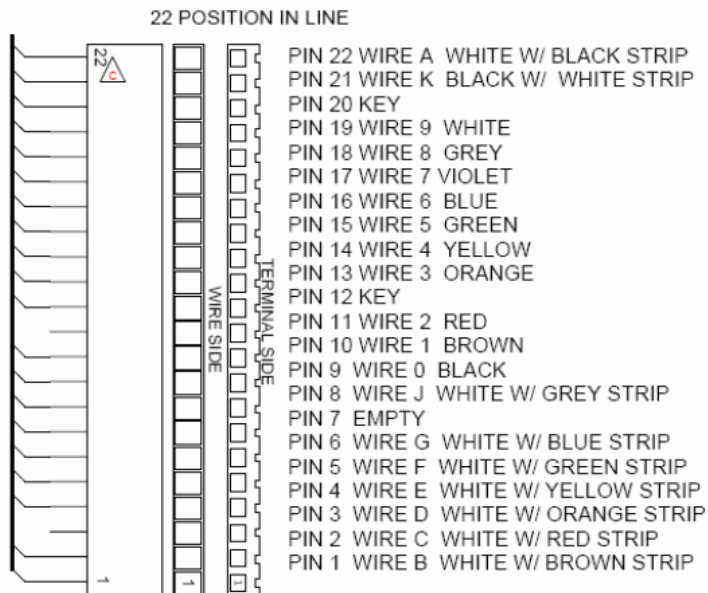

#	Row	Column
	<i>Base color/Stripe color</i>	<i>Solid Color</i>
0	White/Black	Black
1	White/Brown	Brown
2	White/Red	Red
3	White/Orange	Orange
4	White/Yellow	Yellow
5	White/Green	Green
6	White/Blue	Blue
7	White/Grey	Purple
8	Black/White	Grey
9		White

# Snack Shelf

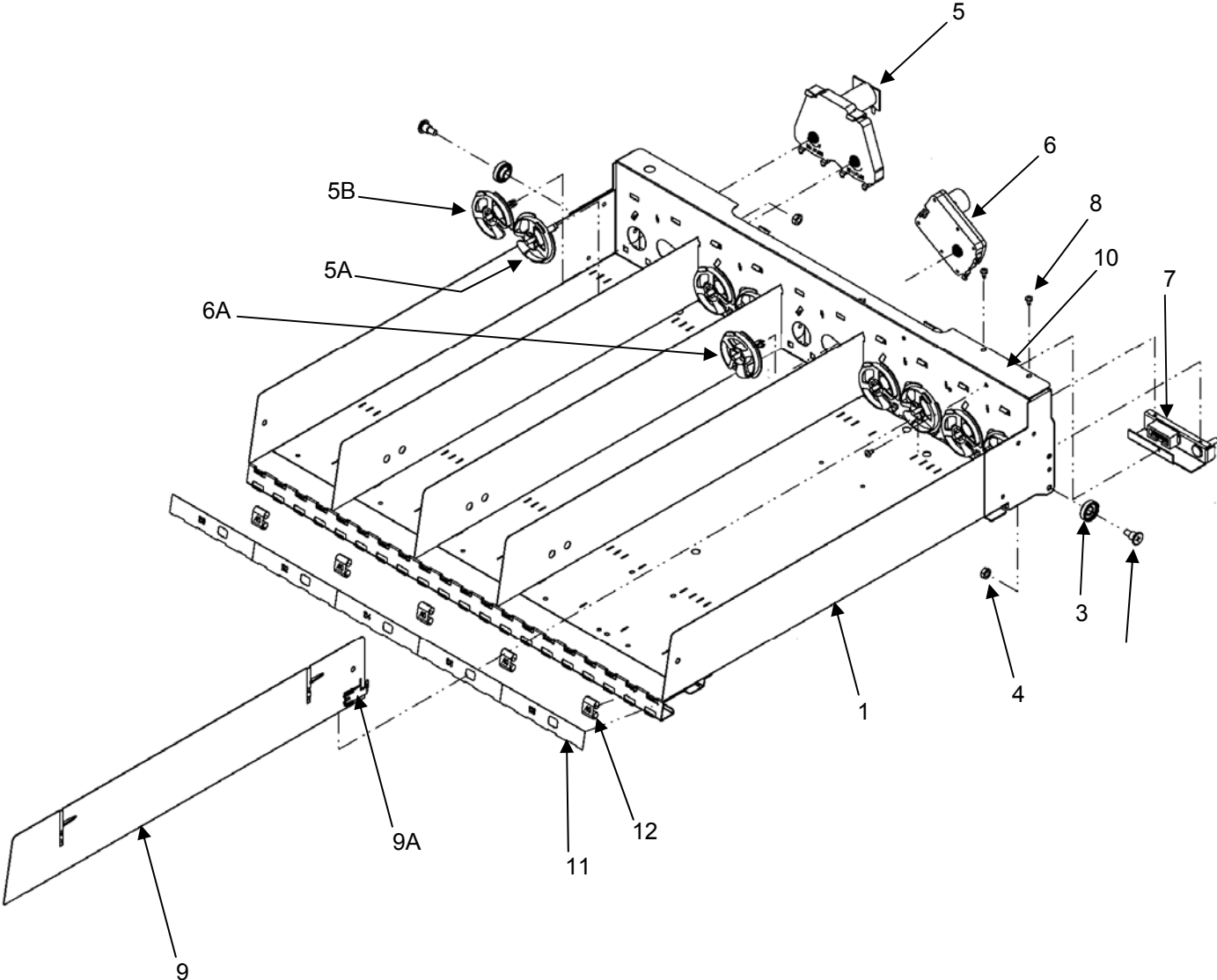

# Snack Shelf

Key	Description	131	132	133
1	Assembly, complete, Pastry shelf w/single blue/white motors (cw)	16600418-01	16600417-01	16600388-02
	Assembly, complete. Convertible shelf. Pastry. Used to increase extra selections. w/o Spirals.	16600418-02	16600417	16600388-03
	Assembly, complete. Dual pastry shelf.	16600418-03	16600417-03	16600388-03
	Pastry shelf, Weldment, only.	16000337	16000336	16000335
2	Screw, shelf roller.	300203	300203	300203
3	Shelf roller	440362	440362	440362
4	Nut, keps (1/4 x 28)	437-41	437-41	437-41
5	Dual spiral motor. (blue/white)	360240	360240	360240
5A	Spiral retainer. White, right hand (RH)	440405	440405	440405
5B	Spiral retainer. Gray, left hand (LH)	440406	440406	440406
6	Shelf motor, CW, (Blue/white)	360275	360275	360275
6A	Spiral retainer. white, right hand (RH)	460405	460405	460405
7	Assembly, complete. Harness with bracket. 5 selections			660435-7
	Assembly, complete. Harness with bracket. Use with convertible shelf.			660435-8
	Assembly, complete. Harness with bracket. 4 selections.	660435-9	660435-9	
	Assembly, complete. Harness with bracket. Use with convertible shelf.	660435-10	660435-10	
	Harness, only. 5 selection shelf.			16800049
	Harness, only. Convertible shelf.	16800074	16800074	16800050
	Harness, only. 4 selection shelf.	16800073	16800073	
8	Screw, Ph. T-23 (8-32 x 5/16)	276-8R5	276-8r5	276-8R5
9	Assembly, Shelf Spacer	16600416-01	16600416	16600416
9A	Spring Only, Shelf Spacer	14400116	14400116	14400116
10	Decal, use with convertible shelf.	460494	460494	460494
11	Selection tabs, Pastry, see page 6.19 for itemized breakdown			
12	Price tabs, Scroll from 40 cents to \$2.40	17400153	17400153	17400153

# Candy / Paired Shelf

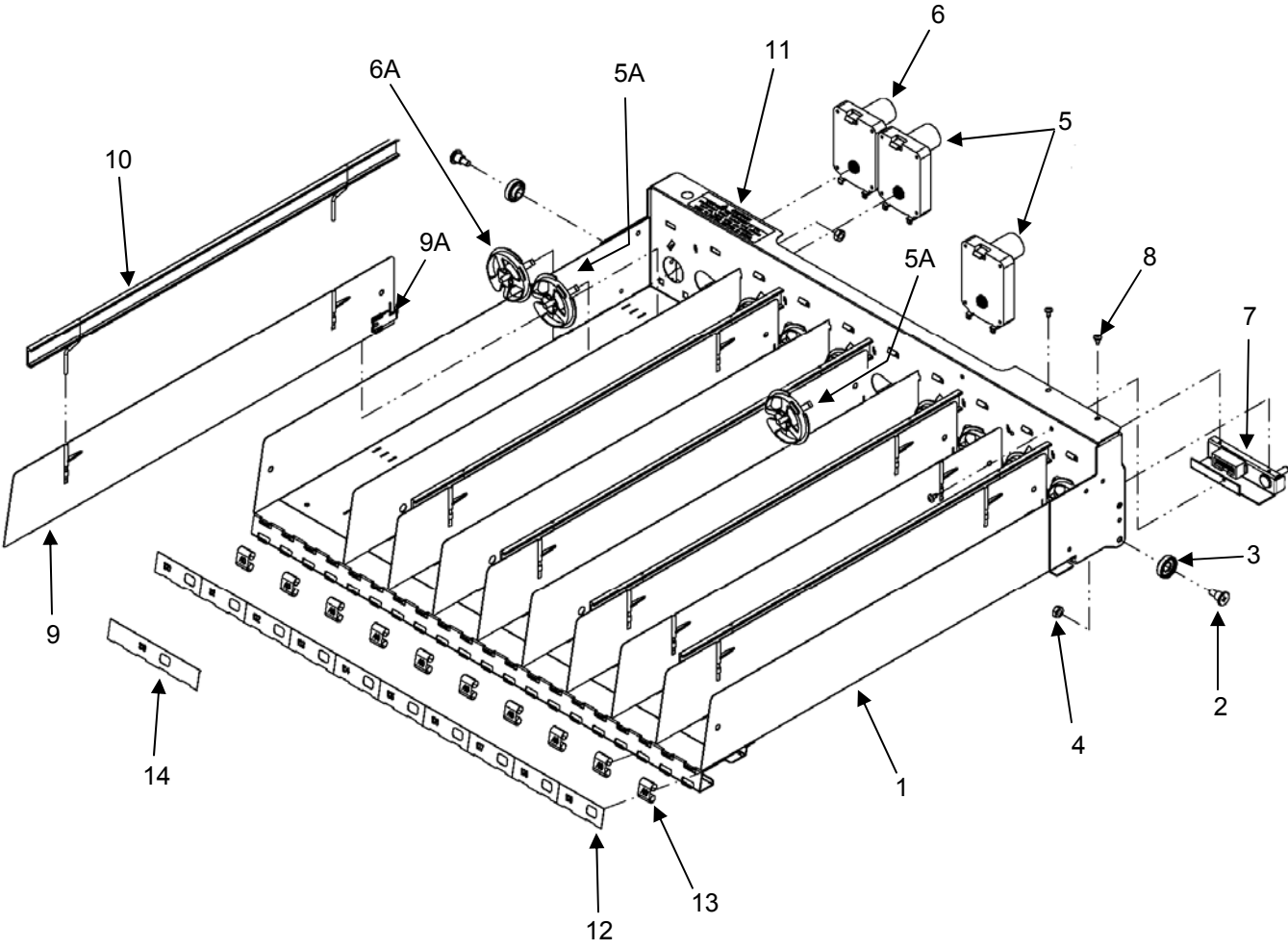



# Candy / Paired Shelf

Key	Description	131	132	133
1	Assembly, complete. Convertible shelf, Candy, Used with all 8 selections being clockwise motors cw (blue/white)	16600418	16600417	16600388
	Assembly, complete. Paired motor candy shelf. Used with a combination of clockwise motors cw (blue/white) and counter clockwise motors ccw (blue/gray)	16600418-04	16600417-04	16600388-07
	Candy shelf, Weldment only.	16000337	16000336	16000335
2	Screw, shelf roller	300203	300203	300203
3	Shelf roller	440362	440362	440362
4	Nut, keps (1/4x28)	437-41	437-41	437-41
5	Vend motor complete. Clockwise CW (blue/white)	360275	360275	360275
5A	Spiral retainer. White, right hand (RH)	440405	440405	440405
6	Vend motor complete. Counter clockwise CCW (blue/gray)	360276	360276	360276
6A	Spiral retainer. Gray, left hand (LH)	440406	440406	440406
7	Assembly, complete, Harness with bracket. 10 selections			660435-8
	Assembly, complete. Harness with bracket. 8 selections	660435-10	660435-10	
	Harness only. 10 selections			16800050
	Harness only. 8 selections	16800074	16800074	
8	Screw, PH.T-23 (8-32x5/16)	276-8r5	276-8r5	276-8r5
9	Assembly, shelf spacer	16600416-01	16600416	16600416
9A	Spring Only, Shelf Spacer	14400116	14400116	14400116
10	Assembly, candy shelf slide	16600389-01	16600389	16600389
11	Decal, use with candy convertible shelves	460494	460494	460494
12	Selection tabs, Candy, see page 6.19			
13	Price tabs. Scroll from 40 cents to 240	17400153	17400153	17400153
14	Selection tabs, Snack, see page 6.19			

# Gum & Mint Shelf

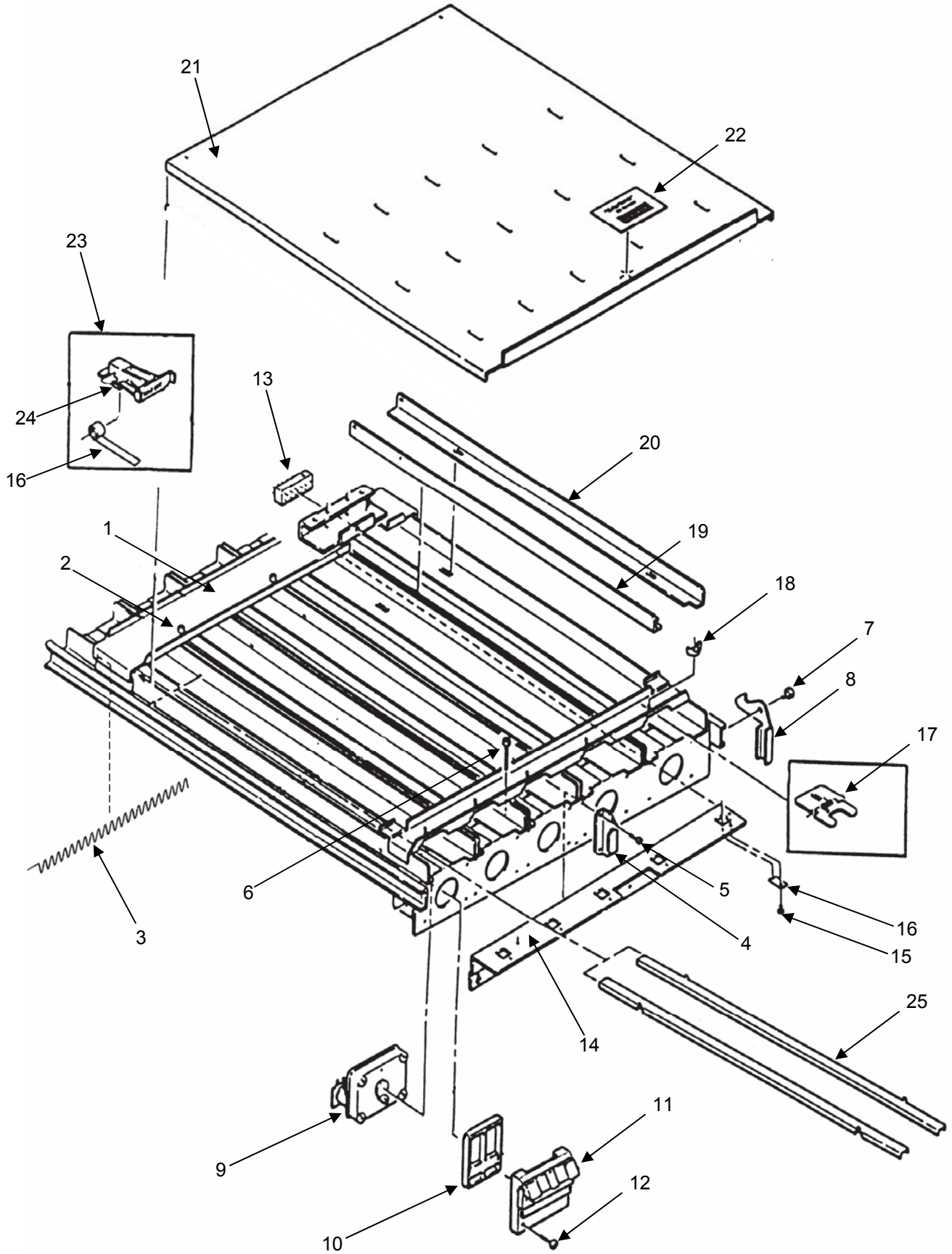

# Gum & Mint Shelf

Key	Description	131	132	133
1	Assembly Complete, G&M Domestic	16600459	16600458	16600457
	Add on Kit, G&M Domestic	750165-30	750165-33	750165-36
	Assembly Complete, G&M Export except Australia	16600462	16600461	16600460
	Add on Kit, G&M Export	750165-31	750165-34	750165-37
	Assembly Complete, G&M Australia	16600465	16600464	16600463
	Add on Kit, G&M Australia	750165-32	750165-35	750165-38
2	Dome Plug, 1/4 Hole	420040-9	420040-9	420040-9
3	Spring, G&M Pusher Stop, Short, Domestic	14000011	14000011	14000011
	Spring, G&M Pusher Stop, Long, Export	14000010	14000010	14000010
4	Shelf Closer	201691-01	201691-01	201691-01
5	Screw (8-32 x 3/8), Pan Head, Self Tap	276-8R6	276-8R6	276-8R6
6	Screw (8 x 1 3/8) Pan Head, Phillips	217-8R22	217-8R22	217-8R22
7	Shoulder Bushing	300184	300184	300184
8	G&M Shelf Latch, Right Side	12000032	12000032	12000032
9	G&M Motor, White	360105	360105	360105
10	G&M Ejector	440267	440267	440267
11	Cover, G&M Ejector	14400107	14400107	14400107
12	Screw (8 x 1), Pan Head, Phillips	218-8R16	218-8R16	218-8R16
13	Harness only, no Bracket, Domestic	16800075	16800076	16800077
	Harness only, no Bracket, Export & Australia	16800078	16800079	16800080
14	Strap, G&M Pusher Stop, Domestic	12000002-03	12000002-03	12000002-02
	Strap, G&M Pusher Stop, Export & Australia	12000002-01	12000002-01	12000002
15	Screw (6-32 x 5/16) Flat Head	262-6R5	262-6R5	262-6R5
16	Spring, G&M Pusher Return	400106	400106	400106
17	G&M Display Hinge Assy. Domestic & Export except Australia	16600335	16600335	16600335
	G&M Display Hinge Assy, Australia Only	660314-1	660314-1	660314-1
18	Wing Nut (8 x 32)	420023	420023	420023
19	Column Spacer, Left	201411-3	201411-1	201411-1
20	Column Spacer, Right	201411-2	201411	201411
21	Cover, G&M Shelf, Domestic	201409-1	201409-2	201409
	Cover, G&M Shelf, Export	201530-1	201530-2	201530
22	Caution Decal, G&M Shelf	460351	460351	460351
23	Assembly Complete, Pusher & Spring	660313	660313	660313
24	Pusher Only, G&M	440265	440265	440265
25*	Thin Mint Adapter	201412-1	201412	201412
*	Optional items			

# Shelf Accessories

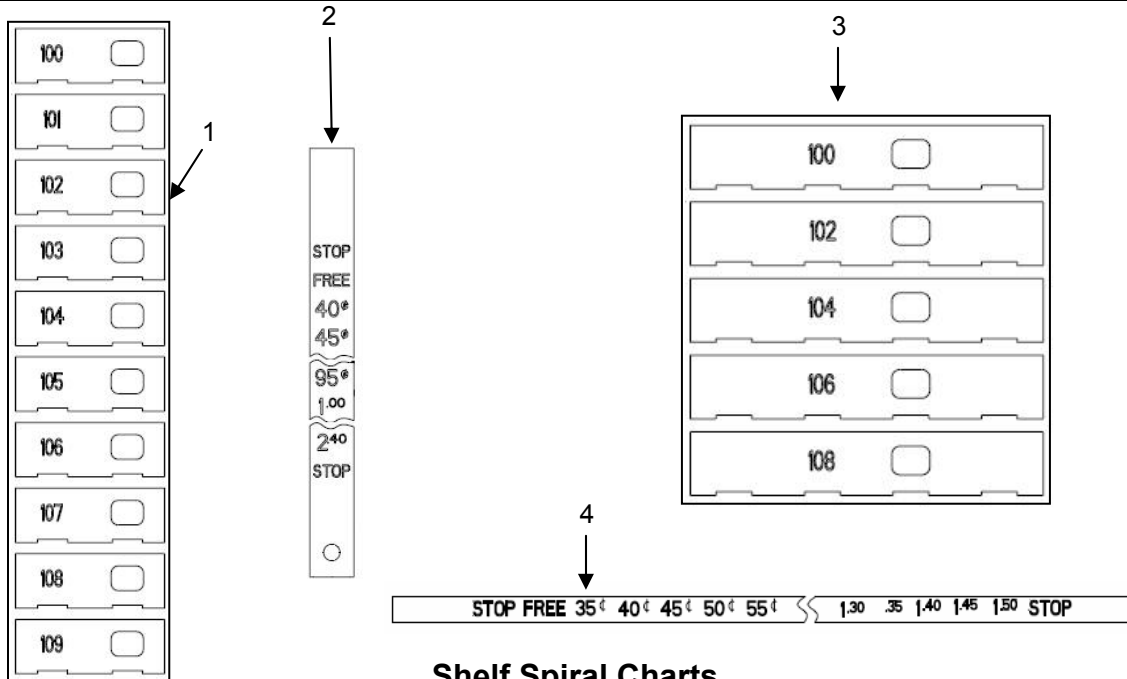

## Shelf Spiral Charts

131 Dual Snack & Paired Candy Spirals		
Left Hand Short Spiral		Right Hand Short Spiral
400186-1	3 ct	400185-1
400184-1	4 ct	400183-1
400174-1	6 ct	400173-1
400175-1	8 ct	400116-1
400176-1	10 ct	400117-1
14000013	12 ct	400118-1
14000014	16 ct	400119-1
	20 ct	400134-1

132 & 133 Dual Snack & Paired Candy Spirals		
Left Hand Long Spiral		Right Hand Long Spiral
	5 ct	14000004-01
14000003-01	6 ct	400167-1
400178-1	7 ct	400164-1
400179-1	9 ct	400166-1
400169-1	10 ct	400168-1
400170-1	12 ct	400120-1
400171-1	15 ct	400121-1
14000015	18 ct	400122-1
14000016	24 ct	400123-1
	30 ct	400135-1
	40 ct	400138-1

Single Snack Spirals		
131 Short Spiral		132 & 133 Long Spiral
400165-1	4 ct	
	5 ct	14000002-01
400124-1	6 ct	400162-1
	7 ct	400153-1
400125-1	8 ct	
400126-1	10 ct	400127-1
	12 ct	400128-1
	15 ct	400129-1
	18 ct	400163-1
	30 ct	400136-1
	40 ct	400137-1

Candy Spirals		
131 Short Spiral		132 & 133 Long Spiral
400185-1	3 ct	
400183-1	4 ct	
	5 ct	14000004-01
400173-1	6 ct	400167-1
	7 ct	400164-1
400116-1	8 ct	
	9 ct	400166-1
400117-1	10 ct	400168-1
400118-1	12 ct	400120-1
	15 ct	400121-1
400119-1	16 ct	
	18 ct	400122-1
400134-1	20 ct	
	24 ct	400123-1
	30 ct	400135-1
	40 ct	400138-1

A blank space means this size spiral is not available for that model.

## Shelf Accessories

---

Key	Description	Part No.
1	Selection Tabs. Numbers 100-109 Candy	17400158
	" " Numbers 110-119 "	17400159
	" " Numbers 120-129 "	17400160
	" " Numbers 130-139 "	17400161
	" " Numbers 140-149 "	17400162
	" " Numbers 150-159 "	17400163
	" " Numbers 160-169 "	17400164
2	Price Label, Self Coiling, \$.40 - \$2.40	17400153
3	Selection Tabs Numbers 100-109 Pastry	17400165
	" " Numbers 110-119 "	17400166
	" " Numbers 120-129 "	17400167
	" " Numbers 130-139 "	17400168
	" " Numbers 140-149 "	17400169
	" " Numbers 150-159 "	17400170
	" " Numbers 160-169 "	17400171
4	G& M Price label, Self Coiling, Horizontal, \$.35 - \$1.50	17400154
NS	Product Pusher, Right Hand	440141-1
NS	Product Pusher, Left Hand	440215

# Delivery Bin

---

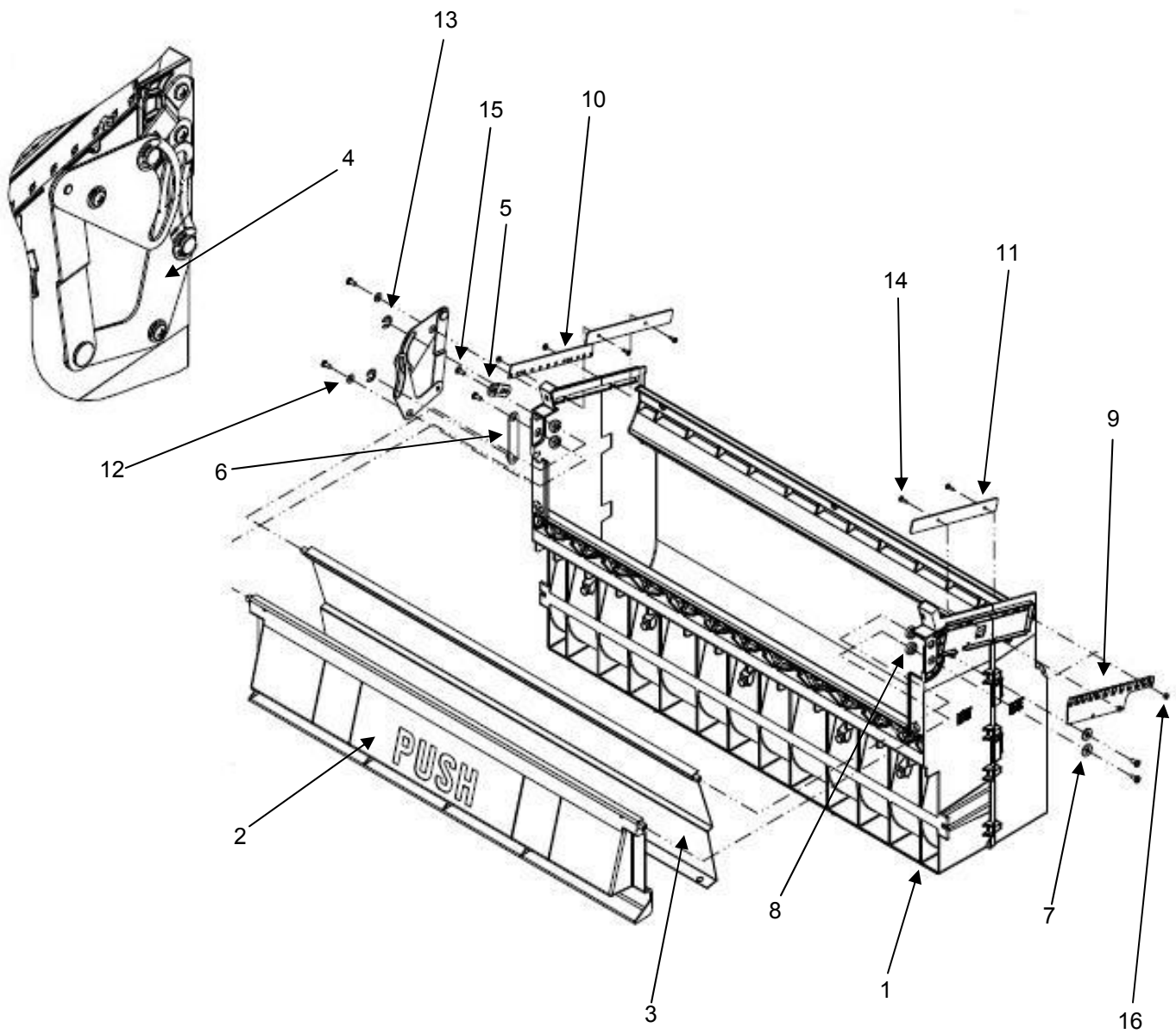

# Delivery Bin

Key	Description	Ambient 131, 132	Ambient 133	Chilled 131, 132	Chilled 133
1	Bin Asm Complete, Black Door, w / Golden Eye	16600383	16600401	16600413	16600414
	Plastic Bin only	16400072	16400083	16400072	16400083
2	Delivery Bin Door - Black	440373-1	440373	440373-1	440373
	Delivery Bin Door - Gray	440373-9	440373-10	440373-9	440373-10
3	Inner Door - Standard	200763-1	200763	200763-1	200763
	Inner Door - Steel	200763-4	200763-3	200763-4	200763-3
4	Bin Door Drive - Pivot	16400076	16400076	16400076	16400076
5	Inner Bin Door Arm	16400070	16400070	16400070	16400070
6	Bin Door Drive Arm	640097	640097	640097	640097
7	Bin Door Washer	420282	420282	420282	420282
8	Door Bearing	440129	440129	440129	440129
9	Golden Eye II Receiver Board	13600020-01	13600020-01		
	Golden Eye II Receiver Board - Coated			13600020-03	13600020-03
10	Golden Eye II Transmitter Board	13600022-01	13600022-01		
	Golden Eye II Transmitter Board - Coated			13600022-03	13600022-03
	Harness Gold Eye Interconnect 120 (Not Shown)	16800101	16800101	16800101	16800101
11	Lens, Golden Eye, Lock & Hinge Side	14400101	14400101	14400101	14400101
12	Washer-# 8	600-8	600-8	600-8	600-8
13	Retaining Ring 3/8	751-37	751-37	751-37	751-37
14	Screw, Pan Hd Mach 4-40 X 3/8	116-4R6	116-4R6	116-4R6	116-4R6
15	8-32x3/8 Ph Pan Hd M/S Zn	116-8R6	116-8R6	116-8R6	116-8R6
16	#4-40 Hex M/S Nut Nylon	13100028	13100028	13100028	13100028
17	Delivery Bin Pad (Not Shown)	12200124	12200124-01	12200124	12200124-01

# 131, 132 & 133 Chiller Assembly

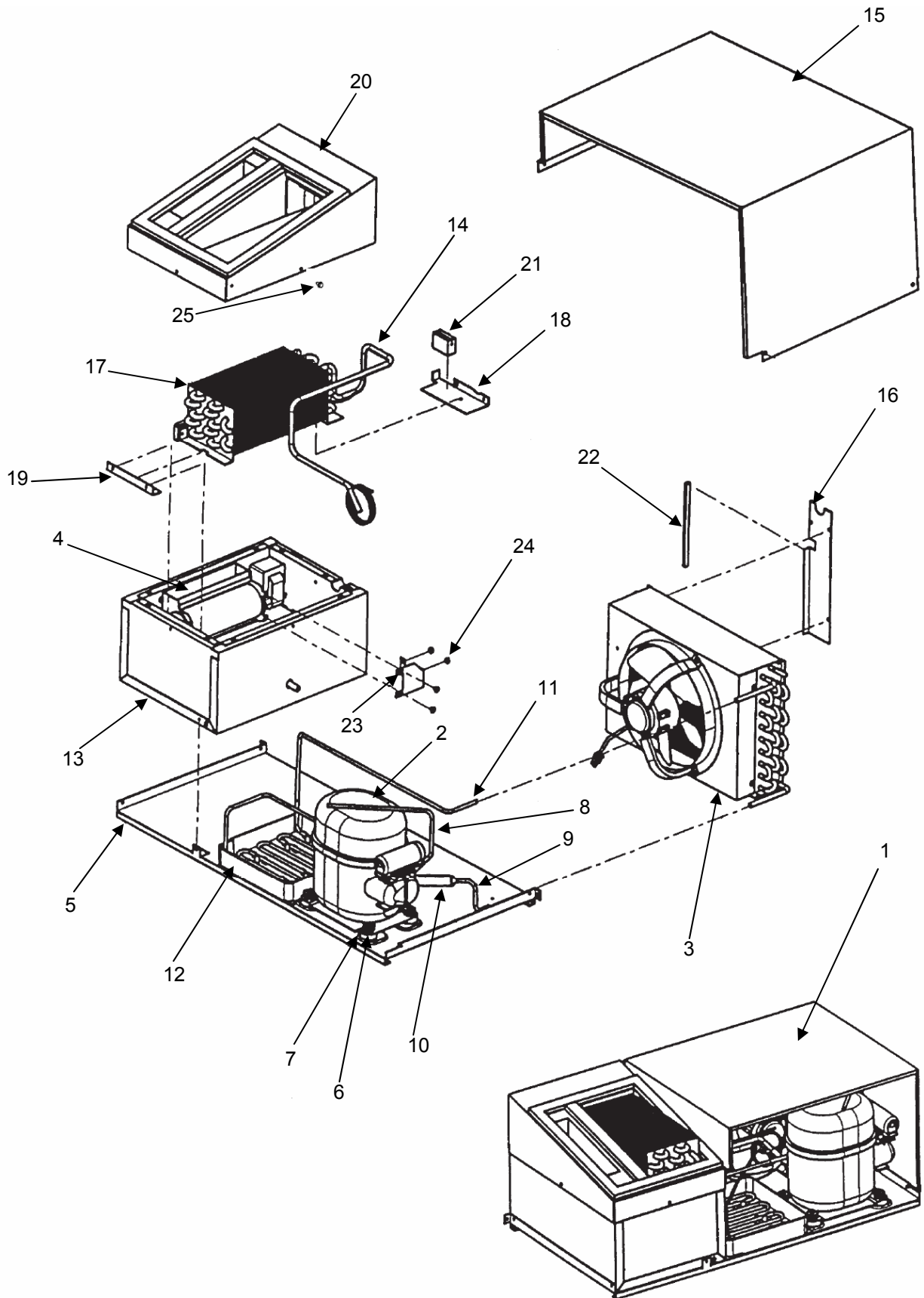



# 131, 132 & 133 Chiller Assembly

Key	Description	117V, 60 Hz Domestic	230V, 50 Hz Export	220V, 60 Hz Brazil
1	Chiller Assembly Complete	16600041	16600041-01	16600108
2	Compressor Complete w Start Components, inc 2A – 2H	360270	360271	16700004
2A	Compressor only	360270-1	360271-1	16700004-01
2B	Start Capacitor	360270-2	360271-2	16700004-08
2C	Capacitor End Cap	360270-5	360271-3	16700004-09
2D	Thermal Overload Switch	360270-8	360271-8	16700004-04
2E	Start Relay	360270-11	360271-11	16700004-10
2F	Compressor Foot	360270-4	360271-4	16700004-05
2G	Electrical Cover	360270-14	360270-14	360270-14
2H	Clip, Electrical Cover	360270-9	360270-9	360270-9
3	Condenser Coil Complete W Fan and Motor			
3a	Condenser Coil Only			
3b	Condenser Fan with Housing.	360269	360269-1	360269-1
3c	Condenser Shroud			
4	Evaporator Fan Motor	16700003	16700003-01	16700003-01
5	Refrigeration Mounting Plate	12000063	12000063	12000063
6	Compressor Mounting Pin	300225	300225	300225
7	Compressor Mounting Clip	420426	420426	420426
8	Tube, Process			
9	Tube, Condenser Outlet			
10	Drier			
11	Tube, Compressor Discharge			
12	Evaporator Pan	440459	440459	440459
13	Evaporator Housing	16400002	16400002	16400002
14	Capillary / Suction Line			
15	Cover, Condensing Unit	12000065	12000065	12000065
16	Bracket Condensing Unit Cover			
17	Evaporator Coil Assembly	16600062	16600062	16600062
18	Evaporator Bracket Rear			
19	Evaporator Bracket Front			
20	Evaporator Housing, Top Assembly	16600040	16600040	16600040
20A	Gasket, Evaporator Housing Top, Outside	13300004	13300004	13300004
20B	Gasket, Evaporator Housing Top, Center	13300003	13300003	13300003
21	Evaporator Air Block	13300005	13300005	13300005
22	Gasket, ¼ X 5/16	13000001	13000001	13000001
23	Evaporator Motor Bracket			
24	Hex Nut, 8 - 32	404-08	404-08	404-08
25	#8 X 3/8 Screw (all Screws)	210-8R6	210-8R6	210-8R6
26	Harness, Compressor (not shown)	16800028	16800028	16800058

**Note: Parts shown for identification without part numbers in columns are not sold separately.**

# 133 Trim & Panels

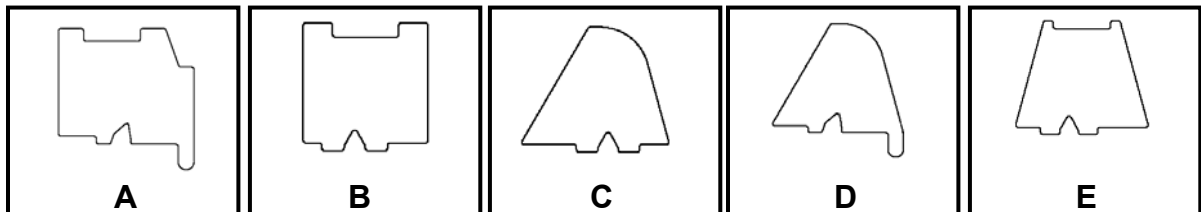
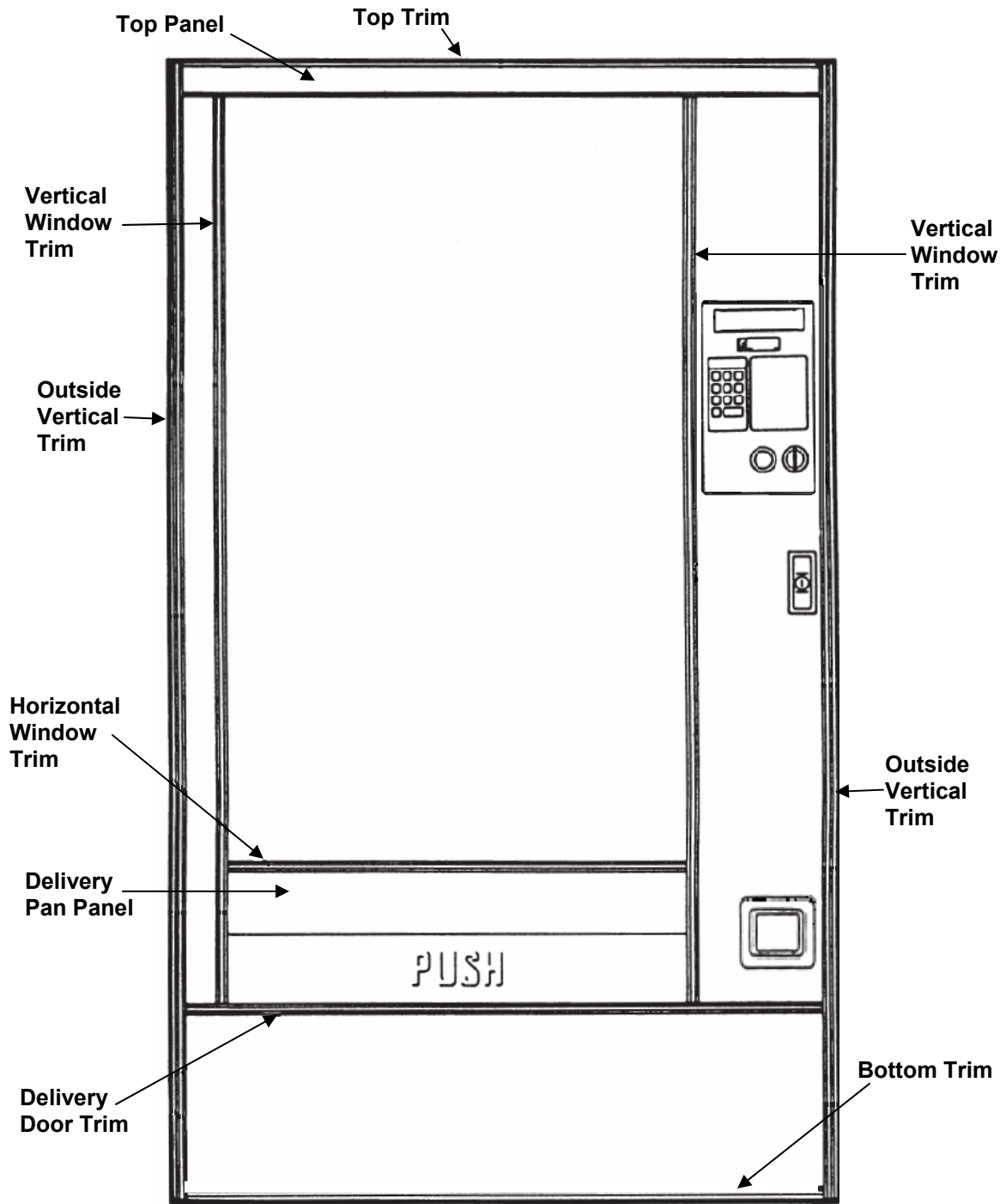

130 Series Trim Profile Chart

# 133 Trim & Panels

133 Trim & Panels			Metro	Aramark	Genesis W/Vinyl	Genesis No Vinyl	Mission	Euro Black Silver Trim	Euro Black Black Trim	Euro Paint Black Trim	Euro Paint Silver Trim	Dimensions
<b>Top Trim</b>	<b>Profile</b>	<b>Part #</b>										
Black – AP Style		13400021-14	1									1.872 x 37.365 in
Silver - AP Style		13400021		1								1.872 x 36.890 in
Black - Rowe Style		13400010-01					1					2.810 x 36.890 in
Silver - Rowe Style		13400010			1	1						2.810 x 36.890 in
Black - Euro Style		13400021-04							1	1		1.872 x 26.997 in
Silver - Euro Style		13400021-03						1			1	1.872 x 26.997 in
<b>Outside Vertical Trim</b>												
Black	D	13400030	2									65.609 Inches
Silver - Taped Trim	A	16600402		2								65.609 Inches
Black	A	13400011-01					2					65.609 Inches
Silver	A	13400011			2	2						65.609 Inches
<b>Window Horizontal Trim</b>												
Black	C	13400013-03	1						1	1		26.997 Inches
Silver	E	13400012		1								26.721 Inches
Black	E	13400012-04			1	1	1					26.721 Inches
Silver	C	13400013-02						1			1	26.997 Inches
<b>Window Vertical Trim</b>												
Black – Right Hand	C	13400013-13	1									52.649 Inches
Black – Left Hand	C	13400013-14	1									52.649 Inches
Silver	E	13400012-02		2								52.394 Inches
Black	E	13400012-05			2	2	2					51.471 Inches
Black	C	13400013-01							2	2		65.406 Inches
Silver	C	13400013						2			2	65.406 Inches
<b>Delivery Door Trim</b>												
Black	C	13400013-12	1									37.275 Inches
Silver	B	13400024		1								36.890 Inches
Black	B	13400024-01			1	1	1					36.890 Inches
Silver	C	13400013-02						1			1	26.997 Inches
Black	C	13400013-03							1	1		26.997 Inches
<b>Bottom Trim</b>												
Door Edging		201678		1	1	1	1					34.891 Inches
<b>Top Panel</b>												
Ara Style		14400137-01		1								1.700 x 36.875 in
Black Hide		201690-12				1						1.672 x 36.875 in
Black Hide		12000860-03						1				1.700 x 26.878 in
Paint		12000860-09								1	1	1.700 x 26.878 in
<b>Delivery Tray Panel</b>												
Black Hide		201356-1	1			1		1	1			3.687 x 26.843 in
Paint		201356-6								1	1	3.687 x 26.843 in
<b>Trim Screws</b>												
Self Tap x .480 Long		13100054	41	41	39	39	39	16	16	16	16	
Self Tap X .450 Long		13100054-01	19	19	19	19	19					

# 131/132 Trim

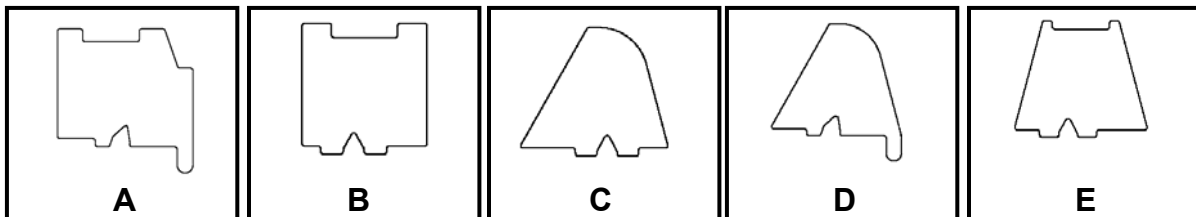
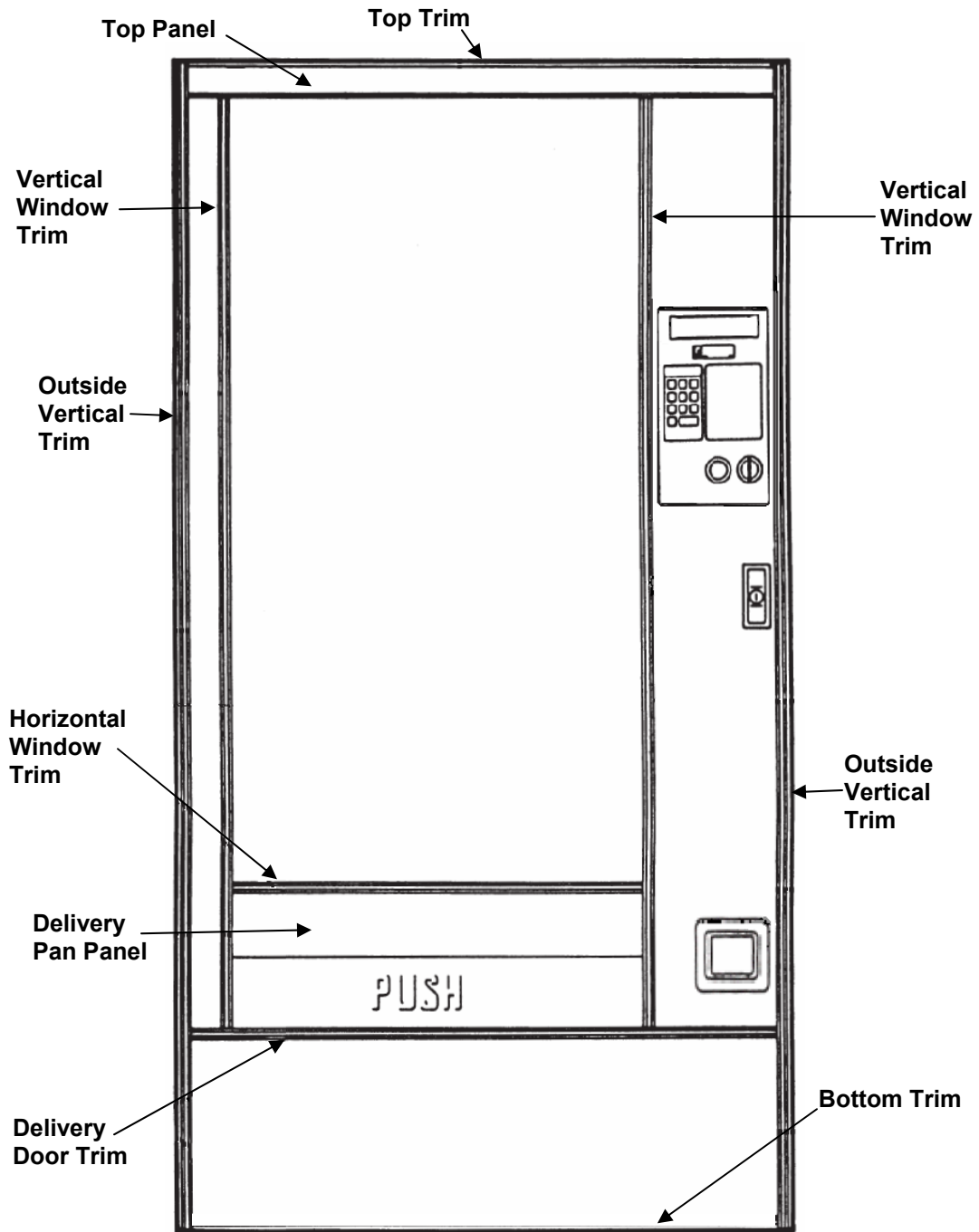

130 Series Trim Profile Chart

# 131/132 Trim

131/132 Trim			Metro	Aramark	Genesis W/Vinyl	Genesis No Vinyl	Mission	Euro Black Silver Trim	Euro Black Black Trim	Euro Paint Black Trim	Euro Paint Silver Trim	Dimensions
<b>Top Trim</b>	<b>Profile</b>	<b>Part #</b>										
Black – AP Style		13400021-15	1									1.872 x 32.372 in
Silver – AP Style		13400021-11		1								1.872 x 31.887 in
Black – Rowe Style		13400010-03					1					2.810 x 31.887 in
Silver – Rowe Style		13400010-02			1	1						2.810 x 31.887 in
Black – Euro Style		13400021-06							1	1		1.872 x 21.657 in
Silver – Euro Style		13400021-05						1			1	1.872 x 21.657 in
<b>Outside Vertical Trim</b>												
Black	D	13400030	2									65.609 Inches
Silver - Taped Trim	A	16600402		2								65.609 Inches
Black	A	13400011-01					2					65.609 Inches
Silver	A	13400011			2	2						65.609 Inches
<b>Window Horizontal Trim</b>												
Black	C	13400013-05	1						1	1		21.656 Inches
Silver	E	13400012-01		1								21.375 Inches
Black	E	13400012-07			1	1	1					21.375 Inches
Silver	C	13400013-04						1			1	21.656 Inches
<b>Window Vertical Trim</b>												
Black – Right Hand	C	13400013-13	1									52.649 Inches
Black – Left Hand	C	13400013-14	1									52.649 Inches
Silver	E	13400012-02		2								52.394 Inches
Black	E	13400012-05			2	2	2					51.475 Inches
Silver	C	13400013						2			2	65.406 Inches
Black	C	13400013-01							2	2		65.406 Inches
<b>Delivery Door Trim</b>												
Black	C	13400013-11	1									32.280 Inches
Silver	B	13400024-03		1								31.887 Inches
Black	B	13400024-02			1	1	1					31.887 Inches
Silver	C	13400013-04						1			1	21.656 Inches
Black	C	13400013-05							1	1		21.656 inches
<b>Bottom Trim</b>												
Edging		201678-2		1	1		1					29.938 Inches
<b>Top Panel</b>												
Ara Style		14400137-02		1								1.700 x 31.887 in
Black Hide		201690-13				1						1.672 x 31.887 in
Black Hide		12000860-04						1				1.700 x 21.538 in
Paint		12000860-10								1	1	1.700 x 21.538 in
<b>Delivery Tray Panel</b>												
Black Hide		201356-2	1			1		1	1			3.687 x 21.500 in
Paint		201356-14								1	1	3.687 x 21.500 in
<b>Trim Screws</b>												
Self Tap x .480 Long		13100054	41	41	39	39	39	15	15	15	15	
Self Tap x .450 Long		13100054-01	19	19	19	19	19					

# Stealth Door Trim & Panels

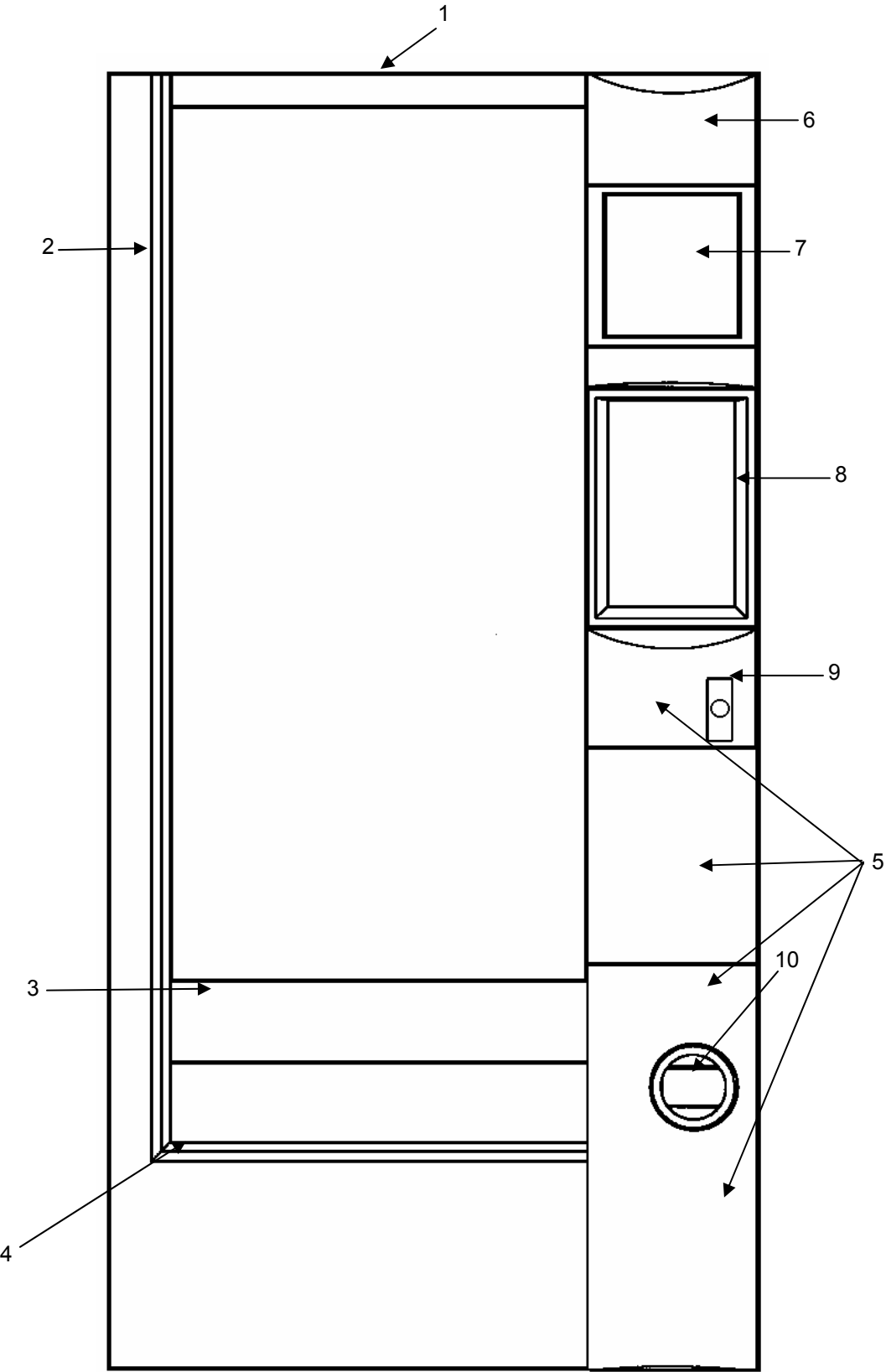

## Stealth Door Trim & Panels

---

Key	Description	131	132	133
1	Top Trim	13400001-04	13400001-04	13400001-03
	Top Trim, Retainer Asm (3 required)	16400011	16400011	16400011
2	Vertical Trim	38647-1	38647-1	38647-1
3	Delivery Bin, Trim	13400002-04	13400002-04	13400002-03
	Bin Trim, Retainer Asm (3 required)	16400010	16400010	16400010
4	Trim, Under Delivery Door	14400009-03	14400009-03	14400009-02
5	Lower Right, Column	38342-1	38342-1	38342-1
6	Upper Right, Column w/POS, Asm	16600444	16600444	16600444
6A	Upper Right, Column W/POS Cut Out	38355-1	38355-1	38355-1
6B	Upper Right, Column, No POS Cut Out	38356-1	38356-1	38356-1
7	Window, POS	38497	38497	38497
7A	Adapter, POS Window	38498-1	38498-1	38498-1
7B	Panel Back, POS Window	38499-1	38499-1	38499-1
7C	POS, Security Bracket	12000200	12000200	12000200
7D	Nut, PAL, ¼ Self Threading (4 required)	18443	18443	18443
8	Trim Ring Bezel, Coin Insert	38527-1	38527-1	38527-1
9	T-handle Lock Asm, w/o latch	38332-2	38332-2	38332-2
10	Door, Coin Return Cup	38529-01	38529-01	38529-01
	Axle, Coin Cup Door	38530	38530	38530

# Service

## Removal of Delivery Bin

- 1) Turn the power to the machine off.
- 2) Disconnect the ribbon cables from either side of the delivery bin, and remove the ribbon cable from the clips on the sides of the bin. The ribbon cable should remain attached to the door weldment.
- 3) Disconnect the control harness from machine harness to the Golden Eye board.
- 4) Using a stubby Phillips screwdriver, push the outer delivery door open, and remove the 2 screws from the inside front edge of the delivery bin, driven into the horizontal door stiffener below the bin. See Photo1 for reference location of these two screws.
- 5) Remove the 2 screws and washers securing the bin on either side of the glass, reference Photo 2.
- 6) Remove the 2 screws and washers attaching the bin to the lower door stiffener, reference Photo 3.
- 7) Remove the bin from the inside of the door by lifting up from the inside of the door.
- 8) Assembly is reverse of disassembly.

### Removal of Gum and Mint Motor

Disconnect the two wires attached to the motor and remove the four screws holding the motor to the shelf. The components attached to the front base can also be replaced. These consist of the gum and mint shelf front (Price tabs and selection), gum and mint shelf front base, gum and mint display front stop (plastic) and the gum and mint ejector.

### Note

- ◆ Before replacing the gum and mint motor it is helpful to first tap the motor with the screws. Assemble the four components together and mount them to the motor, making sure that the head crank of the motor is inserted into the ejector. Replace the four screws and test vend that selection to check for proper operation.

### Removal of Gum and Mint Shelf

Pull the gum and mint shelf out about halfway. Loosen the two screws on each end of the gum and mint pusher stop strap and disengage it from the cabinet. Grasp the shelf and pull straight out. With the shelf out, you can replace the gum and mint pusher by removing the screw.

Reverse this procedure to replace the shelf. Pay special attention that all the gum and mint pushers have spring tension and are behind the strap (when you put the gum and mint pusher stop strap back on).

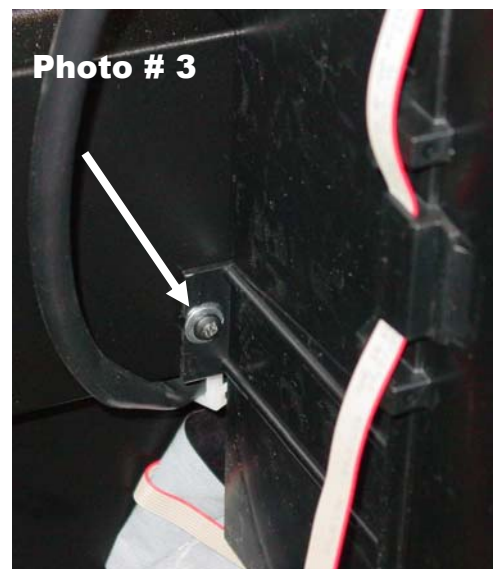
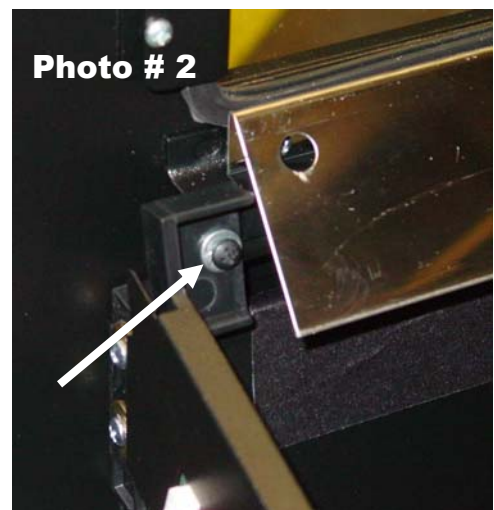



# Service

---

## ST/130 Paired Motor Shelf Conversion Instructions

These instructions provide the steps to convert two candy selections on a paired motor candy shelf to a single dual spiral snack selection, or visa versa.

### Convert Two Candy Selections to One Snack

- 1) Remove product from 2 adjacent spirals – Left hand motor must be an even number.
- 2) Remove divider from between the 2 spirals, and store under machine for future use.
- 3) Remove the selection number tabs from both selections
- 4) Remove one of the 2 scrolling price tabs rolls
- 5) Move the remaining scrolling price tab to position C on drawing below.
- 6) Store removed tabs and scrolling price roll in the service envelope, and retrieve the correctly numbered selection tab from the extras provided in the service envelope.
- 7) Install the new selection tab on the front of the shelf.
- 8) Count the number of spaces in each spiral to verify that they are the same. Change spiral if required.
- 9) Load product in selection.
- 10) Access Mode 23, and pair the motors
- 11) Access Mode 20, and set the new price, and adjust the scrolling price tab as required.
- 12) Test vend with money to ensure correct operation

### Convert One Snack to Two Candy Selections

- 1) Remove product from spirals.
- 2) Install divider between the 2 spirals, between positions B & C.
- 3) Remove the selection number tab from the selection.
- 4) Remove the scrolling price roll.
- 5) Locate the extra selection tabs and scrolling price rolls in the service envelope, and retrieve the correctly numbered selection tabs and a scrolling price roll from the service envelope.
- 6) Install the scrolling price rolls in positions B and D.
- 7) Install the two selection tabs on the front of the shelf in positions A, B and C, D
- 8) Load product in selections.
- 9) Access Mode 23, and disable the paired motors.
- 10) Access Mode 20, and set the new price for both selections, and adjust the scrolling price tabs as required.
- 11) Test vend with money to ensure correct operation.

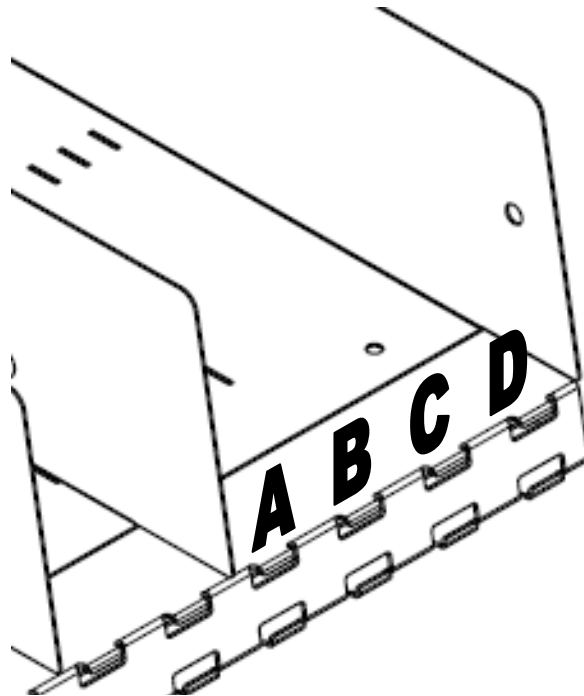

# Troubleshooting

## LCB BOARD CONNECTIONS

### P1 KEYPAD SWITCH LINES

- 1 Row 1
- 2 Row 2
- 3 Row 3
- 4 Row 4
- 5 Row 5
- 6 Key
- 7 Col 1
- 8 Col 2
- 9 Col 3
- 10 N/C

Switch #	Connection A	Connection B
1	PIN 1	PIN 7
2	PIN 1	PIN 8
3	PIN 1	PIN 9
4	PIN 2	PIN 7
5	PIN 2	PIN 8
6	PIN 2	PIN 9
7	PIN 3	PIN 7
8	PIN 3	PIN 8
9	PIN 3	PIN 9
*	PIN 4	PIN 7
0	PIN 4	PIN 8
#	PIN 4	PIN 9
<-	PIN 5	PIN 7
C	PIN 5	PIN 8
->	PIN 5	PIN 9

### P2 SERVICE

- 1 24VDC
- 2 UNDEDICATED RELAY OUTPUT
- 3 SHUTDOWN SWITCH
- 4 SHUTDOWN SWITCH SCAN
- 5 KEY
- 6 DOOR SWITCH
- 7 DOOR SWITCH SCAN

### P3 POWER

- 1 24 VAC
- 2 VAC COMMON
- 3 8 VAC
- 4 N/C
- 5 KEY
- 6 EARTH GROUND

### P4 MDB +

- 1 34VDC
- 2 PWR GND
- 3 8 VDC
- 4 MASTER RXD
- 5 MASTER TXD
- 6 COMMUNICATION COMMON

### P5 SERIAL INTERFACE

- 1 MASTER RECEIVE DATA
- 2 GND
- 3 MASTER TRANSMIT DATA
- 4 KEY
- 5 N/C
- 6 +5 VOLTS

### P6 DC MOTOR DRIVE

- 1 ROW 1 +
- 2 ROW 2 +
- 3 ROW 3 +
- 4 ROW 4 +
- 5 ROW 5 +
- 6 ROW 6 +
- 7 ROW 7 +
- 8 ROW 8 +
- 9 COL 0 -
- 10 COL 1 -
- 11 COL 2 -
- 12 KEY
- 13 COL 3 -
- 14 COL 4 -
- 15 COL 5 -
- 16 COL 6 -
- 17 COL 7 -
- 18 COL 8 -
- 19 COL 9 -
- 20 KEY
- 21 ROW 9
- 22 ROW 10

### P7 CHIP

- 1 INPUT/OUTPUT LINE
- 2 N/C
- 3 KEY
- 4 GND

### P8 FLIP

- 1 VCC
- 2 ALE
- 3 TXD
- 4 RXD
- 5 PSEN
- 6 GROUND

### P9 BATTERY

- 1 +
- 2 -

### P10 LIGHT RELAY

- 1 24VDC
- 2 LIGHT RELAY CONTROL

### P11 GOLDEN EYE/COFFEE SELECTION

- 1 GE ENABLE 1/DATA OUT
- 2 GE SIGNAL 1/DATA IN
- 3 GE ENABLE 2/CLOCK
- 4 STROBE
- 5 GE GROUND/GROUND
- 6 KEY
- 7 GE POWER/8VDC
- 8 GE SIGNAL 2
- 9 GROUND

### P12 DISPLAY

- 1 GROUND
- 2 5VDC
- 3 N/C
- 4 RS
- 5 WR NOT
- 6 KEY
- 7 DB0

### P12 DISPLAY

- 8 DB1
- 9 DB2
- 10 DB3
- 11 DB4
- 12 DB5
- 13 DB6
- 14 DB7

## 130 Series Chiller Control Board

P/N 13600005-01

### Board Layout and Connector Function

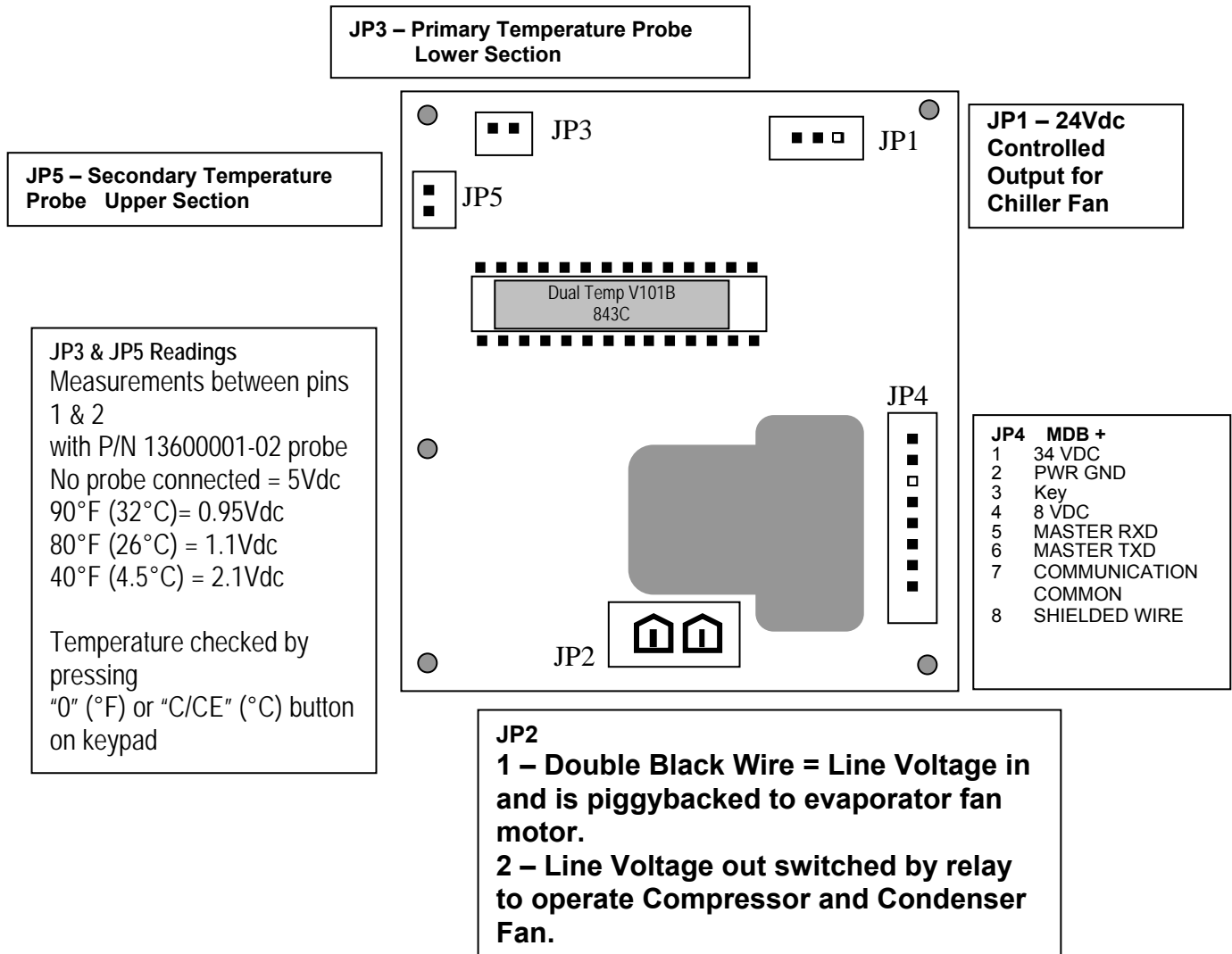

# Troubleshooting

<b>Error on display</b>	<b>Definition of Error</b>	<b>Possible Solutions</b>
<b>MOTOR ERRORS</b>		
MOTOR XXX DIDNT HOME	Vend motor Time Out - XXX represents the selection motor	Motor left the home position, and never returned in the allotted time <ul style="list-style-type: none"> <li>• Check for jammed product in spiral</li> <li>• Check for loose wire on motor</li> </ul>
MOTOR XXX STALLED	Vend motor Over Current	While the motor was running, the current used by the motor exceeded a pre-set threshold <ul style="list-style-type: none"> <li>• Check for jammed product in spiral</li> </ul>
MOTOR XXX OFF HOME	Vend motor Not Home	After the motor has been scanned by the board, and checked for an "at Home" condition, the motor is still not at home <ul style="list-style-type: none"> <li>• Check for a product jam</li> </ul>
BAFFLE x CURRENT	Baffle Motor Over Current – X indicates which cabinet	The baffle door in the Á LA CARTE has experienced an over current condition while attempting to open or close. <ul style="list-style-type: none"> <li>• Check baffle door rod for correct adjustment</li> <li>• Open door and inspect left and right track for dirt – clean as required</li> <li>• Check harness to motor for loose connections</li> <li>• Check for obstructions from delivery bin</li> </ul>
BAFFLE x TIMEOUT	Baffle Motor Timeout - X indicates which cabinet	Motor left the home position, and never reached the open position in the allotted time, or visa versa <ul style="list-style-type: none"> <li>• Check harness to open and closed position switch</li> <li>• Check switches for proper operation</li> <li>• Check pin on baffle door motor crank arm</li> </ul>
LOW VOLTAGE	Low voltage was detected during a Vend	This error will only appear during a vend. This error indicates that a pre-set low voltage threshold was reached for the motor supply circuit. <ul style="list-style-type: none"> <li>• Check the incoming 120Vac supply to the machine – must be within 10% - no lower than 108V</li> <li>• Check for other machines plugged to the same circuit as this machine – rearrange plugs if possible</li> </ul>

# Troubleshooting

<b>CONTROL BOARD &amp; SOFTWARE ERRORS</b>		
XX KEYPAD SW STUCK	Keypad Switch XX Stuck down. See chart below for code definitions.	Either a key on the keypad is stuck or there is damage to the harness from the keypad to the logic board <ul style="list-style-type: none"> <li>• Check the keypad for a broken or damaged button</li> <li>• Check the harness for a pinched or shorted wire</li> </ul>
CABx COMM ERROR	Cabinet Communication error	The Logic Control Board (LCB) has lost communication to the FDB. <ul style="list-style-type: none"> <li>• Check the communications harness between the two boards for damage. If any damage is found, harness should be replaced</li> <li>• Check position of Cabinet Jumper on FDB (C1 or C2) for correct position</li> <li>• Power down and disconnect any MDB payment peripherals, restore power and see if error repeats.</li> </ul>
RAM CHKSUM	RAM CHKSUM	This error will only appear during a power up cycle, and is the result of the contents of the flash memory not agreeing with the stored memory contents on the board. <ul style="list-style-type: none"> <li>• Inspect the board for any physical damage to the smaller flash chip</li> <li>• Access the service mode and perform a complete reset of the control board.</li> </ul>
ROM CHKSUM	ROM CHKSUM	This message will only appear during a power up cycle. The memory contents of the microprocessor on the board have been corrupted, and are not recoverable. The control board must be replaced.
SW TRAP ERROR – XX	Software Trap TBD	
TIME / DATE / BATT ERROR	Time and date have not been set. Battery has failed.	Set time and date. Replace battery.

## Key Pad Switch Stuck Error Codes

Code	Key	Code	Key	Code	Fast Track Key	Code	Fast Track Key
000	1	020	3	040	F1	060	F3
001	4	021	6	041	Service Log	061	Event Log
002	7	022	9	042	Set Shutdown	062	Set Price
003	*	023	#	043	Motor Pairing	063	Bill Escrow
004	<	024	>	044	Interval Sales by Selection	064	Historical Sales by Selection
010	2			050	F2	070	Set Message
011	5			051	Temp Log	071	Golden Eye
012	8			052	Set Temp	072	Set Time
013	0			053	Test Vend	073	Tube Fill
014	C			054	Interval Sales Summary	074	Historical Sales Summary

# Troubleshooting

TEMPERATURE SENSE ERRORS		
HEALTH SHUTDN CAB x	Health Shut down - X indicates which cabinet	This error indicates that the temperature inside the controlled cabinet has exceeded the maximum set temperature for a pre-set period of time. Check the Health Code Error for date and time of occurrence, along with duration and highest temperature reached.
TEMP CAB1 L ZN OPEN TEMP CAB1 H ZN OPEN TEMP CAB2 OPEN	Temperature Sensor CAB X YY ZONE Open X indicates which cabinet YY indicates upper (H ZN) or lower (L ZN)	The Refrigeration Driver Board (RDB) or Food Driver Board (FDB) has detected that the temperature sensor for one of the zones or cabinets is reporting a temperature reading which indicates the sensor is open <ul style="list-style-type: none"> <li>• Check connections to the RDB – sensor should be plugged to board on JP3 for the lower section, and JP5 for the upper section, or P2 on the FDB</li> </ul>
TEMP CAB1 L ZN RANG TEMP CAB1 H ZN RANG TEMP CAB2 RANG	Temperature Sensor CAB X YY ZONE Out of Range X indicates which cabinet YY indicates upper (H ZN) or lower (L ZN)	The RDB or the FDB has detected that the temperature sensor for one of the zones or cabinets is reporting a temperature reading beyond a normal range <ul style="list-style-type: none"> <li>• Check connections to the RDB – sensor should be plugged to board on JP3 for the lower section, and JP5 for the upper section, or P2 on the FDB</li> <li>• Check the temperature probe harness for damage or a short</li> </ul>
TEMP X SENSOR BAD	Temperature Sensor error detected – X indicates which cabinet	This error reports a discrepancy in an Á LA CARTE between the readings of the defrost bimetal and the temperature sensor. If the bimetal is closed, indicating the refrigeration unit is below 40°F, but the temperature sensor is reporting a temperature that is higher, and error is reported. Also would report an error if the opposite is true – the unit temperature is below 40°F, but the bimetal is open. This error can only occur after a health code period has elapsed. <ul style="list-style-type: none"> <li>• Check P2 connector on FDB</li> <li>• Check for physical damage to the sensor, or the harness</li> <li>• Check the bimetal harness for damage</li> </ul>
CABx DEFROST ERROR	Defrost Timeout - X indicates which cabinet	A defrost error is reported when a defrost cycle in an Á LA CARTE exceeds 30 minutes. The controller has terminated the defrost cycle, recorded the error, and turned the refrigeration unit back on. <ul style="list-style-type: none"> <li>• Check defrost heater circuit for voltage and resistance or current draw.</li> <li>• Check defrost relay for proper operation</li> <li>• Check the defrost bimetal for proper operation – should open when temperature inside unit reached 50°F</li> </ul>
CABx SWITCH ERROR	Defrost Switch Error-X indicates which cabinet	A Switch error will only occur in a frozen Á LA CARTE. This error occurs when upon entering a defrost cycle, the bimetal is checked and shows an open status while the temperature being reported is < 20°F. The error is posted, and a fixed 10 minute defrost cycle occurs. <ul style="list-style-type: none"> <li>• Check defrost harness for damaged wire</li> <li>• Verify operation of bimetal defrost sensor</li> </ul>

# Troubleshooting

<b>GOLDEN EYE ERRORS</b>		
GOLDENEYE XXX FAILED	3 Items missed by the Golden EYE Sensor. XXX indicates which selection.	Error would occur is a selection is empty, or if the spiral became disconnected from the motor. This error is reset if the machine door is opened and closed. The error will not be erased until errors are cleared
CABx GOLDENEYE ERROR	Three different selections in a cabinet missed by the Golden EYE Sensor. X indicates which cabinet	As a result of 3 different selections reporting a Golden Eye error, Golden Eye has been disabled for the entire machine. This error is reset if the machine door is opened and closed. The error will not be erased until errors are cleared. Errors for each individual selection with a Golden Eye error should be also reported.
CABx TRAN + REC BAD	All Transmitters and Receivers bad - X indicates which cabinet.	All receivers cannot see any of the transmitters <ul style="list-style-type: none"> <li>• Confirm ribbon cable between the two boards on the bin is correctly plugged in.</li> <li>• Check ribbon cable for damaged wires.</li> </ul>
CABx RECEIVER Y BAD	Receiver (Sensor) Y failed, Y indicates the number of the Sensor, X indicates which cabinet	Sensors are numbered on the G/Eye II boards. Sensor 1 is closest to the inside of the machine through # 12 which is closest to the glass. <ul style="list-style-type: none"> <li>• Check for an obstruction to the specific sensor</li> <li>• Check for physical damage or moisture to the specific sensor</li> </ul>
CABx TRANSMTR Y BAD	Transmitter (LED) Y failed, Y indicates the number of the LED, X indicates which cabinet	The transmitter LEDs are numbered on the G/Eye II boards. LED # 1 is closest to the glass through LED # 12 which is closest to the inside of the machine. <ul style="list-style-type: none"> <li>• Check for an obstruction to the specific LED</li> <li>• Check for physical damage or moisture to the specific LED</li> </ul>
CABx TRN Y TO REC Y	Transmitters Y not seen by a Receiver Y.	In a machine with Golden Eye II, each transmitter sends a beam across the delivery bin to each of the 12 receivers <ul style="list-style-type: none"> <li>• Check for an obstruction to the specific sensor or LED</li> <li>• Check for physical damage or moisture to the specific sensor or LED</li> </ul>

# Troubleshooting

<b>COIN MECHANISM ERRORS</b>		
DEFECTIVE TUBE SENSOR	The changer has detected one of the tube sensors behaving abnormally	Review documentation provided by coin mechanism manufacturer for specific instructions to resolve these errors
CM TUBE JAM	A tube payout attempt has resulted in jammed condition	
CM ROM CHECKSUM ERROR	The changers internal checksum does not match the calculated checksum.	
COIN JAM	A coin(s) has jammed in the acceptance path	
COIN ROUTING ERROR	A coin has been validated, but did not follow the intended routing.	
CREDITED COIN REMOVAL	There has been an attempt to remove a credited coin.	
<b>BILL VALIDATOR ERRORS</b>		
BV DEFECTIVE MOTOR	One of the BV motors has failed to perform its expected assignment.	Review documentation provided by bill validator manufacturer for specific instructions to resolve these errors
BV SENSOR PROBLEM	One of the BV sensors has failed to provide its response.	
BV ROM CHECKSUM ERROR	The validators internal checksum does not match the calculated checksum	
BILL REMOVED	A Credited bill in the escrow position has been removed by an unknown means.	
CASH BOX OUT OF POSITION	The validator has detected the cash box to be open or removed.	
<b>CASHLESS PAYMENT SYSTEM ERRORS</b>		
CL PAYMENT MEDIA ERROR	Cashless Payment media Error	Review documentation provided by cashless system manufacturer for specific instructions to resolve these errors
CL INVALID MEDIA	Cashless Invalid Payment media	
CL TAMPER ERROR	Cashless Tamper Error	
CL REFUND ERROR	Cashless Internal reader credit lost	
CL COMMUNICATIONS ERROR	Cashless Communications Error	
CL REQUIRES SERVICE	Cashless Reader Requires Service	
CL FAILURE	Cashless Reader Failure	
CL MEDIA JAMMED	Cashless Payment media Jammed	



# Studio Series – Software Update Instructions

## 130 Series - Software Update Instructions Using a new Flash Memory Chip



**CAUTION:** The system components in this machine utilize static sensitive components. Precautions for handling sensitive devices should be observed when handling these items.

1. Note any required meter readings or options set.
2. Turn the power switch off.
3. Use a grounding strap and proper anti-static procedures to avoid Electro Static Discharge (ESD) that could damage components on the board.
4. Remove all harnesses from the board except the ribbon cable to the Selection Switches (P1), Display (P12) and Chip (P7).
5. Remove the one screw from the board cover located on the top horizontal edge of the board cover.
6. Remove the board cover by lifting the board cover upward over the latches and pulling forward.
7. Identify the Flash Memory Socket, remove the old software and install the revised software.

**NOTE:** Pay special attention to the alignment notch when installing the chip to prevent damage to either the chip or the socket! Three of the corners have square edges and one edge is cut at an angle, the angled corner lines up with the alignment notch as shown. Press the Flash Memory chip firmly into the socket.

8. Re-install the board cover and all harnesses.
9. Turn the power switch back on.
10. Press the mode button on the board. Enter the reset code 89171819 on the selection keypad, this will reset all options and prices back to factory defaults and reset all accountability back to zero.
11. Press and hold the switch on the top of the door until the "No row \* message" appears.
12. Set prices, options, and test.

The removed chip should be returned for credit

130 Board  
Shown as  
installed in  
machine.

